

CA SERIES ERV

Installation, Operation and Maintenance Manual

CA2XIN

CA3XIN

CA4XIN



CA4XIN shown

⚠ WARNING

RISK OF FIRE, ELECTRIC SHOCK, OR INJURY.

OBSERVE ALL CODES AND THE FOLLOWING:

1. Before servicing or cleaning the unit, switch power off at system disconnect switch or service panel and lock-out/tag-out to prevent power from being switched on accidentally. More than one disconnect switch may be required to de-energize the system for servicing.
2. This installation manual shows the suggested installation method. Additional measures may be required by local codes and standards.
3. Installation work and electrical wiring must be done by qualified professional(s) in accordance with all applicable codes, standards, and licensing requirements.
4. Any structural alterations necessary for installation must comply with all applicable building, health, and safety code requirements.
5. Electrical equipment connected to this unit must be properly grounded.
6. Sufficient air is needed for proper combustion and exhausting of gases through the flue (chimney) of fuel burning equipment that might be installed in the area affected by this equipment. If this unit is exhausting air from a space in which chimney-vented fuel burning equipment is located, take steps to assure that combustion air supply requirements of applicable codes and standards.
7. Use the unit only in the manner intended by the manufacturer. If you have questions, contact the manufacturer.
8. This unit is intended for general ventilating only. Do not use to exhaust hazardous or explosive materials and vapors. Do not connect this unit to range hoods, fume hoods, or collection systems for toxics.
9. This unit must be properly ducted to the outdoors. Outside air inlets must not be located where air may be contaminated, for example by vehicle or appliance exhausts.

⚠ CAUTION

DANGER OF DAMAGE DUE TO CONDENSATION IN OR ON DUCTS TO OUTSIDE.

Both ducts connecting the unit to the outside must be insulated with sealed vapor barriers inside and out to prevent condensation and/or freezing inside the insulation or on the duct surface.

⚠ WARNING

Danger of carbon monoxide poisoning! Outside air intake should be 10' (minimum) away from sources of carbon monoxide or other toxic gases such as chimneys, furnace, or water heater exhausts.

Do not locate outside air intake where vehicles may be serviced or left idling. Do not locate the outside air intake inside an enclosed space.

⚠ WARNING

ALWAYS DISCONNECT POWER SOURCE BEFORE SERVICING, TO ENSURE NO AIR FLOW IN THE SYSTEM.

High volume of air in the case when operating! If you open an access door when the system is running, you may be exposed to as much as 8,000 CFM! Severe eye injury could result!

⚠ CAUTION

Never locate the outside air inlet inside a structure.

⚠ CAUTION

Maximum Differential Pressure

The maximum pressure differential between the two airstreams should not exceed 4 inches (H₂O).

⚠ CAUTION

Install clean filters prior to airflow testing. Select the static pressure test points with care—try several locations and pick the most stable and representative sampling point.

⚠ CAUTION

Filters must be used or the energy exchanger core will become blocked by dust and the unit will not do its job. In extreme cases components may be damaged.

⚠ CAUTION

Do Not Wash the Energy Exchange Core.

Keep it away from water or fire to avoid damaging it. Always handle the core carefully.

SAVE THIS MANUAL

UNIT INFORMATION

Record information as shown below.

In the unlikely event that factory assistance is ever required, information located on the unit label will be needed.

Locate the RenewAire unit label found on the outside of the unit.

NOTE: This information is for purposes of identifying the unit-specific option data from the Option Code.

 NOTE: This page is to be completed by the installing contractor. The completed document is to be turned over to the owner after start-up.

OPTION CODE:

C	A	-		X	J	I	N		-			-	-	-	-	-	-	-	-	-	-	-	-	-	-	-	-	-	N
---	---	---	--	---	---	---	---	--	---	--	--	---	---	---	---	---	---	---	---	---	---	---	---	---	---	---	---	---	---

SERIAL NUMBER:

--	--	--	--	--	--	--	--	--	--

SO #:

--	--	--	--	--	--	--

Energy Recovery Ventilator

This space left blank intentionally.

Option Code: CA-2XJIN--S-----N

MODEL/MODELE: CA2XIN

SO#: 072483

JO#: 42350-0000

Serial Number: **H19 4243**



Label No.
134784_002

UNIT INFORMATION

UNIT LABEL (TYPICAL)

INDOOR UNIT Modular Cabinets

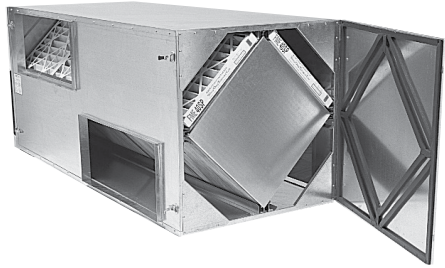

Download specification at:
renewaire.com/specifications

SPECIFICATIONS

Ventilation Type:

Static plate, heat and humidity transfer

Standard Features:

Insulated sheet metal cabinets with energy exchange cores and filters.

Individual CA-Series units or stacks of units can be built into larger air handling systems. Blower not included and must be specified to meet job requirements.

Insulation:

One inch, high density, FSK faced, fiberglass

Options:

Double wall construction

Exterior paint - white, custom colors

Accessories:

Filters - MERV 13, 2" (shipped loose)

Description	CA2XIN	CA3XIN	CA4XIN
Typical Airflow Range CFM	500-2,200	750-3,300	1,000-4,400
AHRI 1060 Certified Core	Two L125-G5	Three L125-G5	Four L125-G5
Unit Dimensions & Weight	36" L x 42 1/2" W x 35" H 225-304 lbs.	36" L x 62 1/4" W x 35" H 325-430 lbs.	36" L x 81 3/4" W x 35" H 400-531 lbs.
Max. Shipping Dimensions & Weight (on pallet)	62" L x 42" W x 40" H 350 lbs.	70" L x 47" W x 40" H 500 lbs.	96" L x 47" W x 40" H 620 lbs.
Filters: MERV 8: 20" x 20" x 2"	Total qty. 4	Total qty. 6	Total qty. 8

AIRFLOW PERFORMANCE

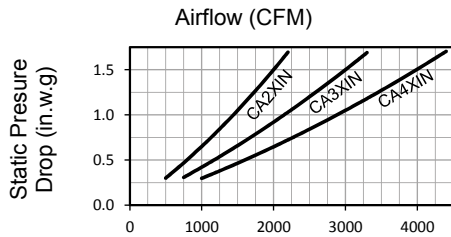

Note: Airflow performance includes effect of clean, standard filter supplied with unit.

APPLICATION

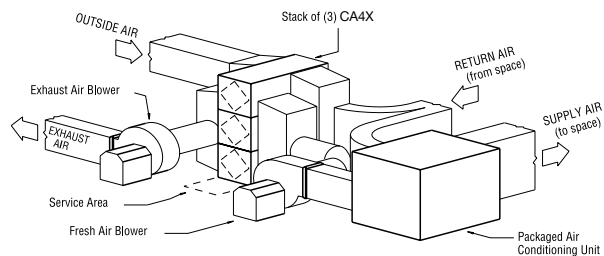

CA2XIN Energy Recovery Module

ABBREVIATION

- EA: Exhaust Air to outside
- OA: Outside Air intake
- RA: Room Air to be exhausted
- FA: Fresh Air to inside

INSTALLATION ORIENTATION

Unit may be installed in any orientation.

NOTE:

1. UNLESS OTHERWISE SPECIFIED, DIMENSIONS ARE ROUNDED TO THE NEAREST EIGHTH OF AN INCH.
2. SPECIFICATIONS MAY BE SUBJECT TO CHANGE WITHOUT NOTICE.

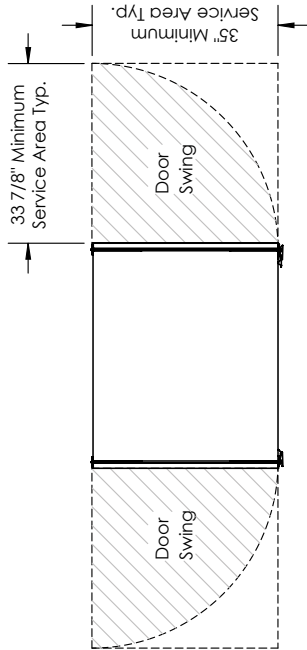

TOP VIEW

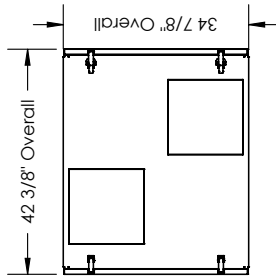

LEFT VIEW

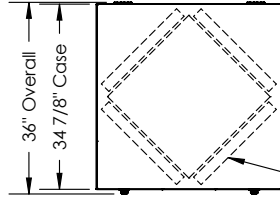

FRONT VIEW

Note: Pleated, disposable 20" X 20" X 2" filters are provided for installation and are interchangeable based on your airflow path requirements. Filters are to be mounted upstream to the core in the direction of airflow entering the unit.

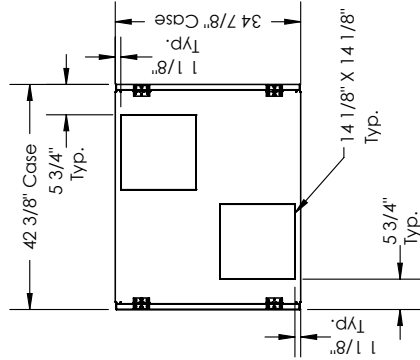

RIGHT VIEW

AIRFLOW CONFIGURATION

Available as shown in dimension drawing.



UNIT MOUNTING & APPLICATION
Can be mounted in any orientation. RA/EA airstream can be switched with OA/FA airstream. Can be stacked three high.

CA3XIN Energy Recovery Module

ABBREVIATION

- EA: Exhaust Air to outside
- OA: Outside Air intake
- RA: Room Air to be exhausted
- FA: Fresh Air to inside

INSTALLATION ORIENTATION

Unit may be installed in any orientation.

NOTE:

1. UNLESS OTHERWISE SPECIFIED, DIMENSIONS ARE ROUNDED TO THE NEAREST EIGHTH OF AN INCH.
2. SPECIFICATIONS MAY BE SUBJECT TO CHANGE WITHOUT NOTICE.

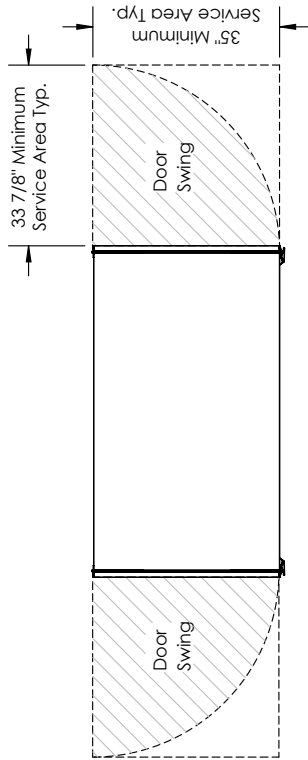

TOP VIEW

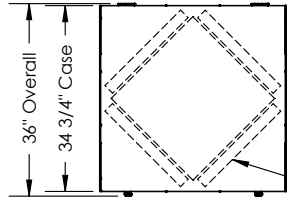

FRONT VIEW

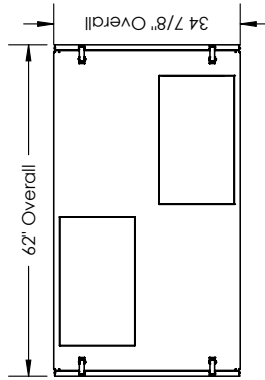

LEFT VIEW

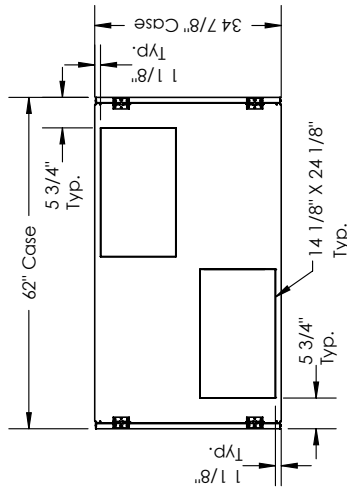

RIGHT VIEW

Note: Pleated, disposable 20" X 20" X 2" filters are provided for installation and are interchangeable based on your airflow path requirements. Filters are to be mounted upstream to the core in the direction of airflow entering the unit.

AIRFLOW CONFIGURATION
Available as shown in dimension drawing.



UNIT MOUNTING & APPLICATION
Can be mounted in any orientation. RA/EA airstream can be switched with OA/FA airstream. Can be stacked three high.

CA4XIN Energy Recovery Module

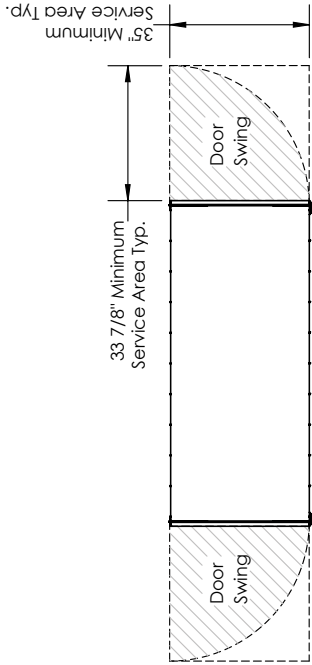

TOP VIEW

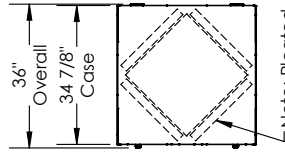

Note: Pleated, disposable 20" X 20" X 2" filters are provided for installation and are interchangeable based on your airflow path requirements. Filters are to be mounted upstream to the core in the direction of airflow entering the unit.

FRONT VIEW

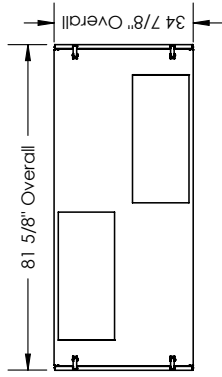

LEFT VIEW

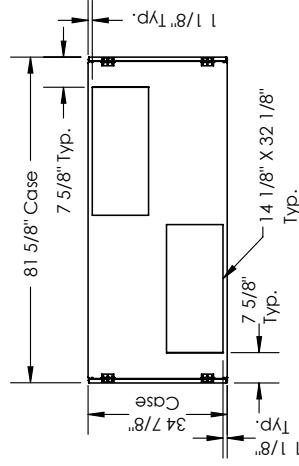

RIGHT VIEW

ABBREVIATION

- EA: Exhaust Air to outside
- OA: Outside Air intake
- RA: Room Air to be exhausted
- FA: Fresh Air to inside

INSTALLATION ORIENTATION

Unit may be installed in any orientation.

NOTE:

1. UNLESS OTHERWISE SPECIFIED, DIMENSIONS ARE ROUNDED TO THE NEAREST EIGHTH OF AN INCH.
2. SPECIFICATIONS MAY BE SUBJECT TO CHANGE WITHOUT NOTICE.



AIRFLOW CONFIGURATION
Available as shown in dimension drawing.



UNIT MOUNTING & APPLICATION
Can be mounted in any orientation. RA/EA airstream can be switched with OA/FA airstream. Can be stacked three high.

1.0 OVERVIEW	10	3.2 CHECKING THE OPERATION OF THE CA-SERIES INDOOR CABINETS	16
1.1 CA-SERIES INDOOR OPERATION.....	10	3.2.1 Airflow—General.....	16
1.2 APPLICATION GUIDELINES.....	10	3.3 ENERGY EXCHANGE.....	16
1.2.1 Purpose of CA-Series Indoor Cabinets	10	3.4 OPERATING CONTROLS.....	16
1.2.2 General Layout	10	3.5 CONTINUOUS OPERATION	16
1.2.3 Stacked Installations.....	11	3.6 OPERATION IN EXTREME COLD WEATHER	16
1.2.4 Location	11	3.7 FIELD MEASUREMENT OF AIRFLOW THROUGH CORES	17
1.3 SERVICE ACCESS.....	11	4.0 MAINTENANCE	17
1.3.1 Service Access	11	4.1 CHANGING THE FILTERS	17
1.3.2 Connection to HVAC System.....	11	4.2 CLEAN THE ENERGY EXCHANGE CORE	18
2.0 INSTALLATION	12	4.3 FILTERS	18
2.1 BLOWER ORIENTATION	12	4.3.1 Filter Specifications	18
2.1.1 Push-Push and Pull-Pull—Recommended	12	4.3.2 Filter Resistance.....	18
2.1.2 OA Push—EA Pull—Use with Caution	12	5.0 FACTORY ASSISTANCE	19
2.2 BLOWER SIZING	13		
2.3 STATIC PRESSURE DROP THROUGH THE CABINET .	13		
2.4 STACKED INSTALLATIONS.....	14		
2.5 SPECIAL CONSIDERATIONS FOR OUTSIDE AIR AND EXHAUST AIR DUCTS	15		
3.0 OPERATION	16		
3.1 PRINCIPAL OF OPERATION	16		

TABLE OF ILLUSTRATIONS

Figure 1.2.0 Opposite Side Airflow Entries.....	10
Figure 1.2.1 Same Side Airflow Entries.....	10
Figure 1.3.0 CA-Series Indoor Cabinet Application Example	11
Figure 2.1.0 “Push-Push” Blower Orientation	12
Figure 2.1.1 “Pull-Pull” Blower Orientation	12
Figure 2.1.2 “OA Push- EA Pull” Blower Orientation.....	12
Figure 2.1.3 “RA Push- FA Pull” Blower Orientation Not Recommended.....	12
Figure 2.3.0 Rated Pressure Drop Through Cabinet	13
Figure 2.4.0 Stack and Secure Cabinets.....	14
Figure 2.4.1 Attach Flanges	14
Figure 2.4.2 Flange Sizes for use in Stacked Installations.....	14
Figure 2.4.3 Connect Ductwork.....	15
Figure 4.3.0 CA-2X Initial Pressure Drop 20" x 20" MERV 8 Filters	18
Figure 4.3.1 CA-3X Initial Pressure Drop 20" x 20" MERV 8 Filters	19
Figure 4.3.2 CA-4X Initial Pressure Drop 20" x 20" MERV 8 Filters	19

MODEL NUMBER	C	A	-			J	I	N	-	-	-	-	-	-	-	-	-	-	-	-	-	-	-	-	N
DIGIT NUMBER	1	2	3	4	5	6	7	8	9	10	11	12	13	14	15	16	17	18	19	20	21	22	23	24	25

Digits 1 - 5:	Model
"CA-2X" = Cabinet Applied 2 Cores	
"CA-3X" = Cabinet Applied 3 Cores	
"CA-4X" = Cabinet Applied 4 Cores	

Digit 24:	Other Options
"- " = None	
"X" = Custom Unit	

Digit 11:	Wall Type
"S" = Single	
"D" = Double	

Digit 25:	Safety Listing
"N" = Non-Listed	

***NOTES:**
 Digit 6 "J" = G5 Core Type Digits 9-10 and 12-23 are not used in these models.

CAUTION
 Never locate the outside air inlet inside a structure.

NOTE: Filters are placed at the INLET FACE of the energy exchange core.

OA = Outside Air into unit.
 RA = Return Air into unit.
 FA = Fresh Air to inside.
 EA = Exhaust Air to outside.

1.0 OVERVIEW

1.1 CA-SERIES INDOOR OPERATION

The CA-Series Indoor cabinets have one basic purpose: to transfer heating or cooling energy from an exhaust airstream to a fresh airstream.

The CA-Series Indoor cabinets operate with no moving parts. The cores in the modules will transfer energy between the two airstreams as long as the two system blowers are moving air through the module. (These blowers are separate from the cabinets).

1.2 APPLICATION GUIDELINES

1.2.1 Purpose of CA-Series Indoor Cabinets

The CA-Series Indoor cabinet(s) are modular cases with 2, 3, or 4 energy recovery cores. The cabinets may be installed individually, or may be stacked and manifolded for larger-capacity installations. A variety of duct connection configurations are possible. Disposable filters are provided; they are of a common size and can easily be replaced.

1.2.2 General Layout

The CA-Series Indoor cabinet(s) are used to transfer energy from exhaust air leaving a building, into fresh air being brought in from the outside for ventilation. By recovering energy from the exhaust airstream, the benefits of ventilation can be enjoyed without the full energy cost to condition the outside air.

The CA-Series Indoor cabinet(s) do not contain blowers. Therefore, two blowers must be installed as part of the system. Several ducts must also be installed.

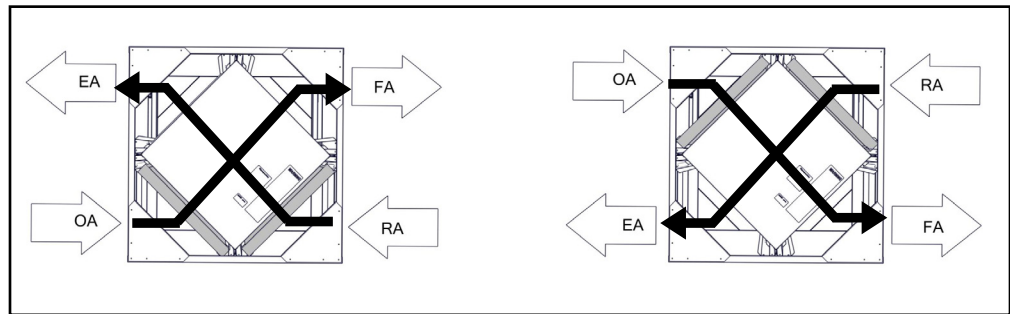

FIGURE 1.2.0 OPPOSITE SIDE AIRFLOW ENTRIES

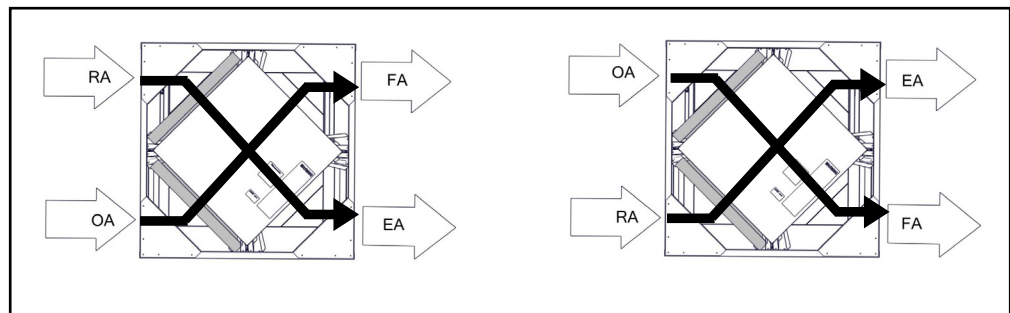

FIGURE 1.2.1 SAME SIDE AIRFLOW ENTRIES

1.2.3 Stacked Installations

When the installation requires more airflow than a single CA-Series Indoor cabinet can handle, up to three cabinets can be stacked and manifolded.

1.2.4 Location

The CA-Series Indoor cabinet is designed for installation in a sheltered location, out of the weather. The ideal location for the CA-Series Indoor cabinet is central to the inside duct runs, and close to both the exhaust air duct (to the outside) and the fresh air duct (from the outside).

1.3 SERVICE ACCESS

1.3.1 Service Access

Install the ERV where you can remove the door for cleaning the core and filter. Although there is no electrical connection to the cabinet(s), there should be a nearby system disconnect switch, so service people can shut off the blowers connect to the system when changing filters.

1.3.2 Connection to the HVAC System

In most cases, one or two ducts connect the CA-Series Indoor cabinet to the building's ducted HVAC system. A variety of connection approaches are possible, depending on the number of CA-Series Indoor cabinets in the installation, purpose of the system, and available space.

Cabinets may be flipped and rotated to fit the job. Whatever orientation of the cabinet is selected, the airstreams must cross, as shown below.

The filters must cover the INLET FACES of the cores. Filter racks are provided at each face to handle all possible airflow configurations.

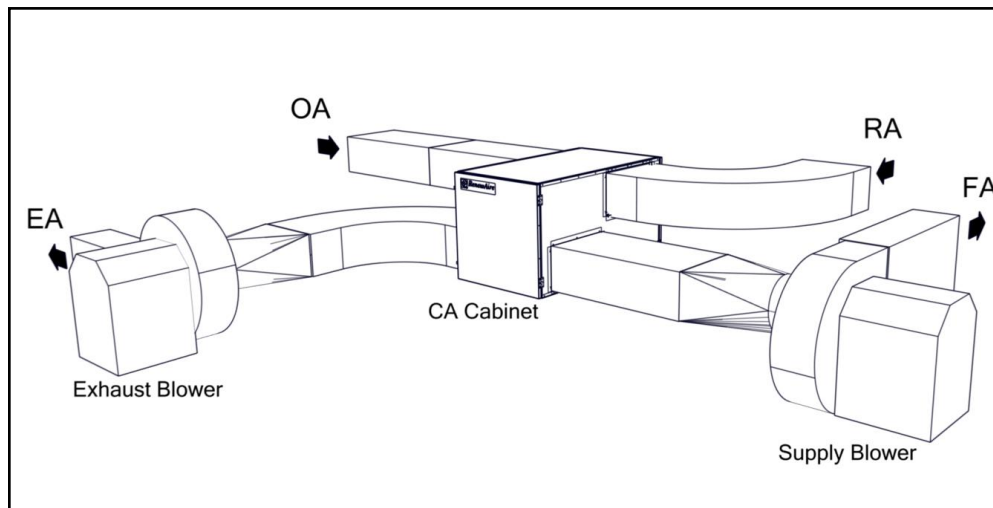

FIGURE 1.3.0 CA-SERIES INDOOR CABINET APPLICATION EXAMPLE

CAUTION

The maximum pressure differential between the two airstreams should not exceed 4 inches (H₂O).

2.0 INSTALLATION

2.1 BLOWER ORIENTATION

Two blowers will be required: one for the air to be exhausted from the building, another for the fresh air to be brought into the building. See diagram for proper and improper blower locations.

2.1.1 Push-Push and Pull-Pull—RECOMMENDED

These are the recommended blower orientations for virtually every application. In “Push-Push” applications, both push from the cabinet(s). In “Pull-Pull” applications, both pull from the cabinet(s).

With Push-Push or Pull-Pull blower orientations, there is generally no need to review the static pressure differences between the two airstreams.

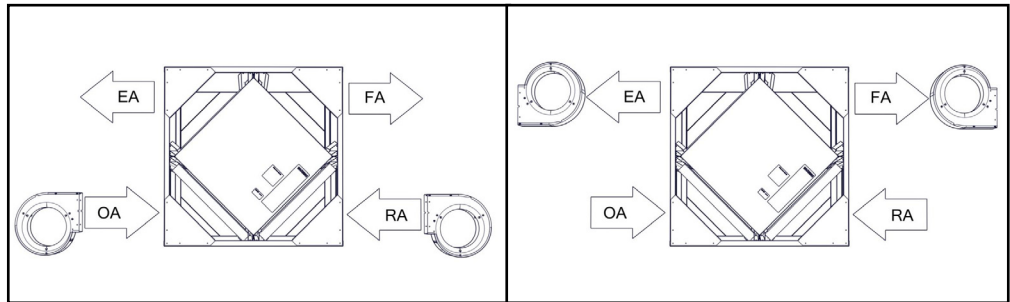

FIGURE 2.1.0 “PUSH-PUSH” BLOWER ORIENTATION

FIGURE 2.1.1 “PULL-PULL” BLOWER ORIENTATION

2.1.2 OA Push—EA Pull—USE WITH CAUTION

This blower orientation causes the supply airstream to be at a much higher static pressure than the exhaust airstream. This may result in bypass airflow, which must be evaluated in the design process.

NOTE: This bypass air volume is lower than in most competing technologies, such as heat wheels, and even some other plate-type exchangers.

The advantage to this orientation is that both blowers are on the “outside” of the cabinets, taking advantage of the acoustic attenuation offered by the cabinets. If outside airstream bypass airflow occurs, it additionally insures no exhaust contaminants leak past seals into the fresh air.

The disadvantage to this orientation is that both blowers must be sized to provide the additional bypass air, which in most cases is a needless waste of energy.

The higher overall static pressure tend to increase duct leakage.

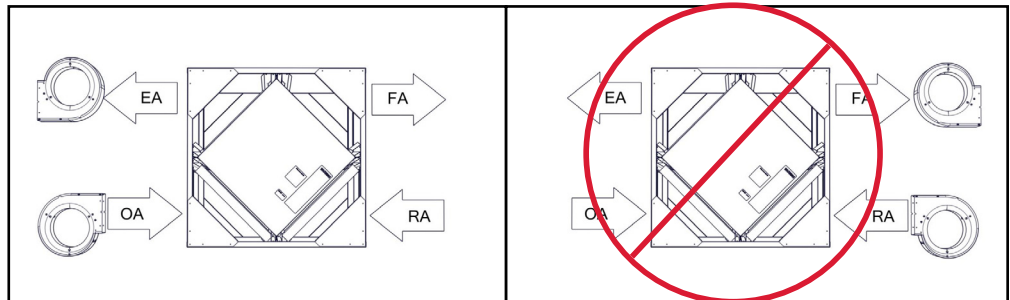

FIGURE 2.1.2 “OA PUSH-EA PULL” BLOWER ORIENTATION

FIGURE 2.1.3 “RA PUSH-FA PULL” BLOWER ORIENTATION NOT RECOMMENDED!

2.2 BLOWER SIZING

Most “low airflow” problems in the field are caused by under-sized blowers. Systems can under-perform if the designer does not make sufficient allowance for duct leakage, variations in duct layout from ideal design, less-than-ideal blower outlet conditions, dirty filters, and the like.

In general, ventilation systems with energy-recovery components tend to need blowers with relatively high static pressure curves. In addition, parts of the duct system may be operating at higher static pressures than usual, and greater duct leakage may result. While these effects may be small, they may consume a large portion of the “safety factor” that a designer conventionally adds in every blower selection exercise.

Given all these concerns, it is prudent to select blowers and motors that can be operated at higher RPMs than required by the nominal design.

2.3 STATIC PRESSURE DROP THROUGH THE CABINET

The following chart is to be used when considering a Push-Push or Pull-Pull orientation of the blowers. The chart represents clean filters. It will be necessary to add an additional drop to allow for the build-up of dirt on the filters.

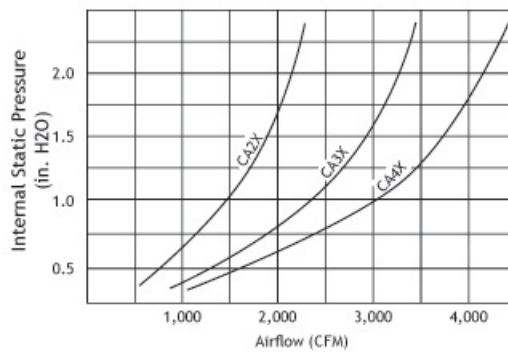

FIGURE 2.3.0 RATED PRESSURE DROP THROUGH CABINET

2.4 STACKED INSTALLATIONS

When the installation requires more airflow than a single CA-Series Indoor cabinet can handle, up to three cabinets can be stacked and manifolded.

1. Stack and align the cabinets. Make sure all Inlets and Outlets are visible! Open the doors. Drive 1-1/2" self-drilling sheet metal screws through the door frames of the upper cabinet into the lower cabinet. See Figure 2.4.0.

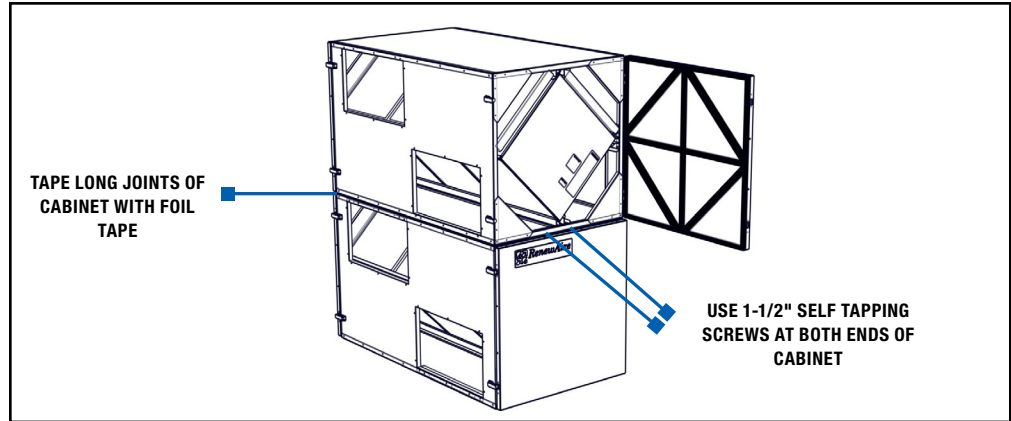

FIGURE 2.4.0 STACK AND SECURE CABINETS

2. Fabricate and attach four sets of flanges on the sides of the stacked cabinets. Each flange will enclose one opening of each cabinet. See Figure 2.4.1.

See Figure 2.4.2 for flange sizes for various cabinet stacks.

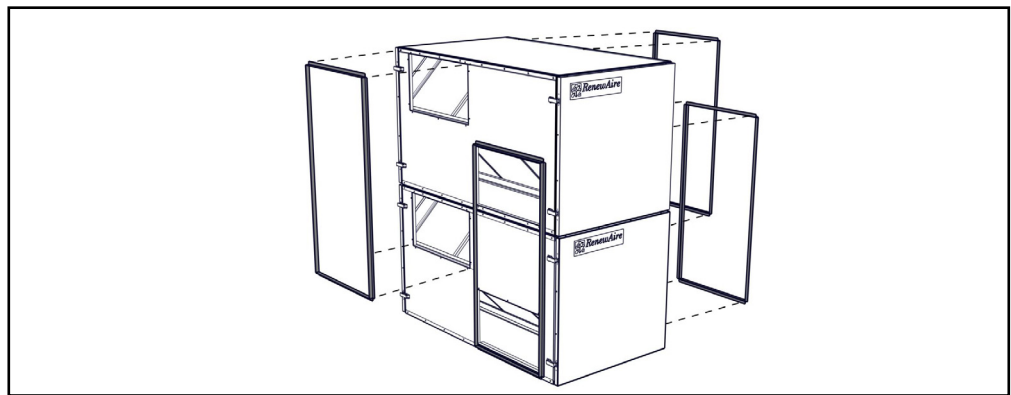

FIGURE 2.4.1 ATTACH FLANGES

MODEL	NUMBER OF UNITS IN STACK		
	1 UNIT	2 UNITS	3 UNITS
CA-2X	14" x 14"	14" x 50"	14" x 84"
CA-3X	24" x 14"	24" x 50"	24" x 84"
CA-4X	32" x 14"	32" x 50"	32" x 84"

FIGURE 2.4.2 FLANGE SIZES FOR USE IN STACKED INSTALLATIONS

3. Connect ductwork to the flanges. See Figure 2.4.3.

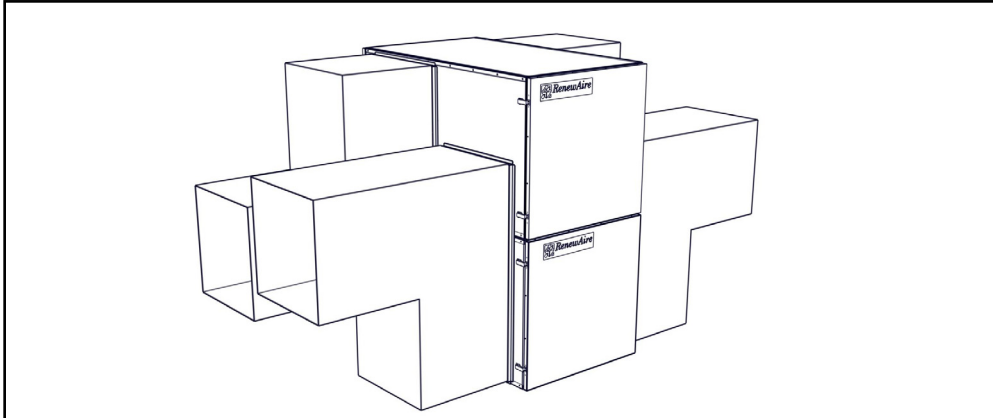

FIGURE 2.4.3 CONNECT DUCTWORK

2.5 SPECIAL CONSIDERATIONS FOR OUTSIDE AIR AND EXHAUST AIR DUCTS

⚠ WARNING

Danger of carbon monoxide poisoning! Outside air intake should be 10' (minimum) away from sources of carbon monoxide or other toxic gases such as chimneys, furnace, or water heater exhausts.

Do not locate outside air intake where vehicles may be serviced or left idling. Do not locate the outside air intake inside an enclosed space.

⚠ CAUTION

Danger of Damage Due to Condensation in or on Ducts to Outside.

Both ducts connecting the unit to the outside must be insulated with sealed vapor barriers inside and out to prevent condensation and/or freezing inside the insulation or on the duct surface.



NOTE: Some jurisdictions may allow less separation, or may require more. Check with your local code officials!



NOTE: The exhaust outlet should not dump air into an enclosed space or any other structure. The inlets and outlets should be screened against insects and vermin and shielded from the weather to prevent the entry of rain or snow.

3.0 OPERATION

3.1 PRINCIPAL OF OPERATION

The CA-Series Indoor has one basic purpose: to exhaust air from a structure and bring in fresh air from outside, while transferring heating or cooling energy from the exhaust air to the fresh air.

The CA-Series Indoor is a very simple device, and will accomplish this purpose as long as the blowers for both airstreams are able to move air through the energy-exchange core.

3.2 CHECKING THE OPERATION OF THE CA-SERIES INDOOR CABINETS

3.2.1 Airflow—General

Airflow should be occurring in both airstreams. Sometimes the easiest place to confirm that air is moving is at the weatherhoods where air is exhausted and brought in.

If exact airflow is critical, it may be desirable to permanently install flow measuring stations and manometers in the ductwork connected to the unit. These also can be used to determine when filters should be cleaned or changed.

3.3 ENERGY EXCHANGE

Precise determination of installed sensible energy exchange effectiveness requires careful measurement of temperatures and air flows in all four airstreams.

The temperature increase or decrease in each airstream is a function of:

1. the number of cores in the system;
2. the flow rates of the two airstreams;
3. the temperature difference between the two airstreams.

See the product specification sheets to determine the energy exchange effectiveness under specific conditions.

3.4 OPERATING CONTROLS

The operating controls are entirely separate from the CA-Series Indoor cabinets. A wide variety of control schemes may be selected by the engineering, installer, or owner to meet the ventilation needs of the facility.

3.5 CONTINUOUS OPERATION

Continuous operation is acceptable in virtually all conditions. Unit will not be damaged by continuous operation as long as air flow occurs. Blower motors may overheat if filters become completely blocked due to lack of maintenance. With continuous operation, in very cold weather (see below), some frost may accumulate on the outside of the case. If the system is cycled off periodically, this frost will evaporate. Frost on the outside of the case does not necessarily indicate any frost inside the energy exchange core.

3.6 OPERATION IN EXTREME COLD WEATHER

Unit is capable of operating at outside temperatures down to -10°F, with indoor humidities below 40%, without any internal frosting. Unit can operate at more severe conditions occasionally with little or no impact on its performance. At lower humidities, it can operate at lower outside temperatures without freezing the energy-exchange core.

3.7 FIELD MEASUREMENT OF AIRFLOW THROUGH CORES

In most cases, conventional test-and-balance methods will be used to confirm proper airflows in the entire ventilation system.

Sometimes it is desirable to estimate airflow in the CA-Series Indoor cabinets themselves, for example, to localize the location of duct leaks. If it is possible to obtain stable static pressure readings just upstream of the inlets and just downstream of the outlets, the static pressure drop curves on page 7 can be expected to be accurate to +/- 10%.

⚠ CAUTION

Install Clean Filters Prior to Testing.

Select the static pressure test points with care—try several locations and pick the most stable and representative sampling point.



NOTE: The filters supplied in the unit are usually able to keep the energy exchange core clear for several months. Finer filters can be used, but must be cleaned more often. If using finer filters, their increased resistance to flow must be allowed for in the system design.

4.0 MAINTENANCE

4.1 CHANGING THE FILTERS

Inspect and/or replace filters every 2–3 months when the unit is in regular use, or as needed. In some applications it may be necessary to replace the filters more frequently.

- Turn off unit completely! Lock-out and tag-out the system disconnect switch.
- Open the door. The door is secured with turn-type latches.
- Remove and dispose of all filters. Replace all filters.
- Close the door.

4.2 CLEAN THE ENERGY EXCHANGE CORE

Clean the core annually or every 5000 operating hours, whichever comes first. Dust collects only on the faces of the energy exchange core. The interior of the energy exchange core stays clean even if the core faces are dust-covered.

- Remove the filters.
- Vacuum the exposed faces of the energy exchanger core with a soft brush.
- Vacuum out dust from the rest of the unit case.
- Install new filters.

If necessary, it is possible to remove the cores. Reach in to grasp the back of each core, and pull it gently forward. If it is difficult to remove, you may want to lightly oil the four projecting lips of the core before replacing it in the unit.

The energy exchange core should not need replacement in normal use. If you think a replacement is required, contact your local representative, or the factory.

IMPORTANT

Make sure all four lips of the core enter the receiver channels when re-inserting the core into the unit.

⚠ CAUTION

Filters must be used or the energy exchanger core will become blocked by dust and the unit will not do its job. In extreme cases components may be damaged.

⚠ CAUTION

Do Not Wash the Energy Exchange Core.
Keep it away from water or fire to avoid damaging it. Always handle the core carefully.

⚠ WARNING

ALWAYS DISCONNECT POWER SOURCE BEFORE SERVICING, TO ENSURE NO AIR FLOW IN THE SYSTEM.

High volume of air in the case when operating! If you open an access door when the system is running, you may be exposed to as much as 8,000 CFM! Severe eye injury could result!

4.3 FILTERS

4.3.1 Filter Specifications

- 20" x 20" x 2" (nominal) pleated filters
- Actual size: 19.5" x 19.5" x 1.75"

Units are shipped with MERV 8 Filters. Minimum recommended effectiveness is MERV 6.

4.3.2 Filter Resistance

Initial Resistance of Filters supplied with this unit:

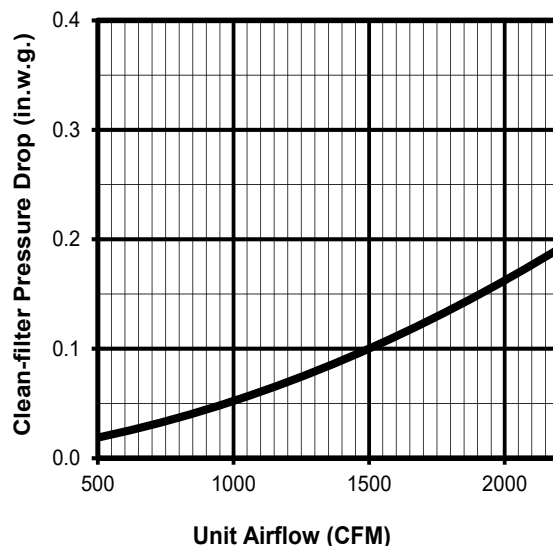

FIGURE 4.3.0 CA-2X INITIAL PRESSURE DROP 20" X 20" MERV 8 FILTERS

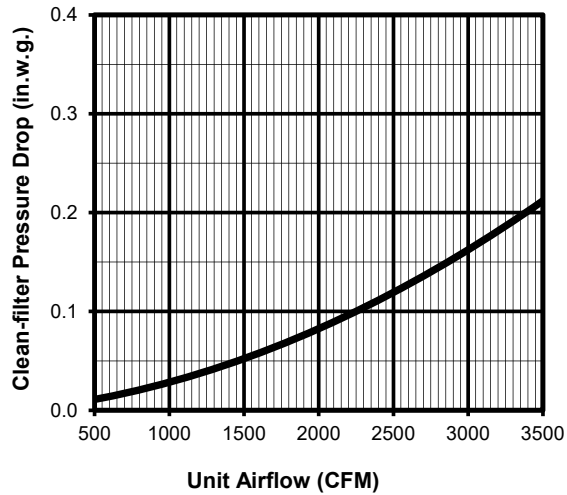

FIGURE 4.3.1 CA-3X INITIAL PRESSURE DROP 20" X 20" MERV 8 FILTERS

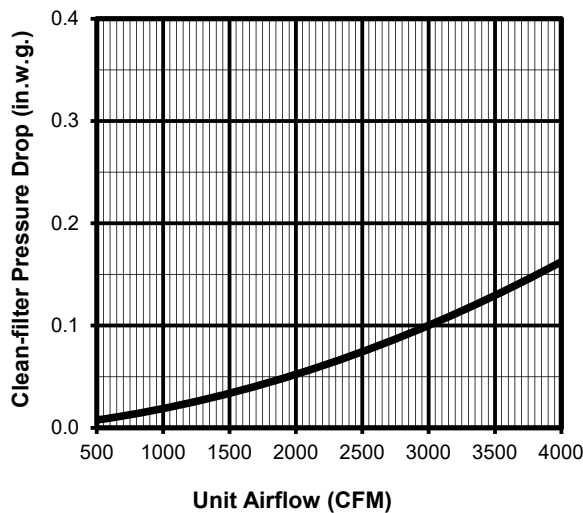

FIGURE 4.3.2 CA-4X INITIAL PRESSURE DROP 20" X 20" MERV 8 FILTERS

5.0 FACTORY ASSISTANCE

In the unlikely event that you need assistance from the factory for a specific issue, make sure that you have the information called for in the Unit Records page in the Owner Information section of this manual. The person you speak with at the factory will need that information to properly identify the unit and the installed options.

To contact RenewAire Customer Service:

Call 800-627-4499

Email: RenewAireSupport@RenewAire.com

Remember that RenewAire Customer Service can only assist with the products sold by RenewAire, it cannot resolve engineering issues that result from air handling system design by others.



About RenewAire

For over 30 years, **RenewAire** has been a pioneer in enhancing indoor air quality (IAQ) in commercial and residential buildings of every size. This is achieved while maximizing sustainability through our fifth-generation, static-plate, enthalpic-core **Energy Recovery Ventilators (ERVs)** that optimize energy efficiency, lower capital costs via load reduction and decrease operational expenses by minimizing equipment needs, resulting in significant energy savings. Our ERVs are competitively priced, simple to install, easy to use and maintain and have a quick payback. They also enjoy the industry's best warranty with the lowest claims due to long-term reliability derived from innovative design practices, expert workmanship and **Quick Response Manufacturing (QRM)**.

As the pioneer of static-plate core technology in North America, RenewAire is the largest ERV producer in the USA. We're **committed to sustainable manufacturing** and lessening our environmental footprint, and to that end our Waunakee, WI plant is 100% powered by wind turbines. The facility is also one of the few buildings worldwide to be LEED and Green Globes certified, as well as having achieved ENERGY STAR Building status. In 2010, RenewAire joined the Soler & Palau (S&P) Ventilation Group in order to provide direct access to the latest in energy-efficient air-moving technologies. For more information, visit: renewaire.com

201 Raemisch Road | Waunakee, WI | 53597 | 800.627.4499 | RenewAire.com