



CA & PA SERIES

APPLIED CATALOG

DECEMBER 2019

RENEWAIRE.COM | 800.627.4499

BECAUSE INDOOR AIR QUALITY MATTERS

As buildings become more airtight due to better construction methodologies, the need for increased and balanced ventilation is critical. Without it, internally generated contaminants accumulate and cause **deficient indoor air quality (IAQ)**, which leads to significant health and cognitive problems for occupants. Industry standards are changing to combat deficient IAQ, and codes that adopt these new standards are driving the

application of ERV technologies. Deficient IAQ is a serious problem, especially considering:

- ♦ On average, Americans spend 90% of their time indoors
- ♦ The EPA found that indoor air may be 2-5 times—and occasionally greater than 100 times—more polluted than outdoor air
- ♦ The EPA ranks indoor air pollutants as a top-five environmental health risk to occupants



ADVERSE EFFECTS OF **DEFICIENT IAQ**

Deficient IAQ has numerous adverse effects on the health and cognitive function of building occupants.



Health problems: Acute allergies, headaches, coughs, asthma, skin irritations and breathing difficulties, as well as chronic illnesses such as cancer, liver disease, kidney damage and nervous-system failure.



Cognitive impairment: Studies by the Harvard School of Public Health and the Lawrence Berkeley National Laboratory found that carbon dioxide (CO₂)—an indoor air contaminant—negatively impacted thinking and decision-making at levels commonly found inside homes and buildings.

ABOUT RENEWAIRE

For over 30 years, **RenewAire has been a pioneer in enhancing IAQ** in commercial and residential buildings of every size. This is achieved while maximizing sustainability through our fifth-generation, enthalpic-core, static-plate Energy Recovery Ventilators (ERVs) that **optimize energy efficiency**, lower capital costs via **HVAC load reduction** and **decrease operational expenses** by minimizing equipment needs, resulting in significant energy savings. Our ERVs are competitively priced, simple to install, easy to use and maintain, have a quick payback and enjoy the industry's best warranty with the lowest claims due to long-term reliability. In 2010, RenewAire joined the Soler & Palau (S&P) Ventilation Group, providing direct access to the latest in energy-efficient air-moving technologies. For more information, visit: renewaire.com.



TABLE OF CONTENTS

CA SERIES - Applied

MODEL	TYPE	CFM RANGE	PAGE
CA2XIN	Indoor	500-2,200 CFM	4-5
CA3XIN	Indoor	750-3,300 CFM	4, 6
CA4XIN	Indoor	1,000-4,400 CFM	4, 7
CA2XRT	Rooftop	500-2,200 CFM	8-9
CA3XRT	Rooftop	750-3,300 CFM	8, 10
CA4XRT	Rooftop	1,000-4,400 CFM	8, 11

PA SERIES - Applied

MODEL	TYPE	CFM RANGE	PAGE
PA6X	Indoor	1,500-6,600 CFM	12-13
PA8X	Indoor	2,000-8,800 CFM	12, 14
PA9X	Indoor	2,250-9,900 CFM	12, 15
PA12X	Indoor	3,000-13,200 CFM	12, 16

ABOUT RENEWAIRE	2-3
SPECIFICATIONS & DIMENSIONS	4-16
ORDERING & SUPPORT	19-20



RENEWAIRE ERVs ACHIEVE SUSTAINABLE IAQ

RenewAire is a pioneer in enhancing IAQ while maximizing sustainability through enthalpic-core, static-plate Energy Recovery Ventilators (ERVs) that **optimize energy efficiency, lower costs by reducing HVAC loads and therefore reduce environmental footprints**. Our ERV technology preconditions incoming air with the otherwise-wasted energy (heat and humidity) of the exhaust air going out—all while the airstreams are kept physically separate as certified by the Air Conditioning, Heating and Refrigeration Institute (AHRI) for low-to-zero Exhaust Air Transfer Ratio (EATR) at typical static pressure differentials. As the pioneer of static-plate core technology in North America, RenewAire is the largest ERV producer in the USA.

OPTIMIZING ENERGY EFFICIENCY

Energy efficiency is optimized by preconditioning the outside air coming in with the **otherwise-wasted heat and humidity** of the exhaust air going out. This exchange of energy moderates temperatures and moisture, decreases HVAC equipment needs, drives operational efficiencies and conserves energy.

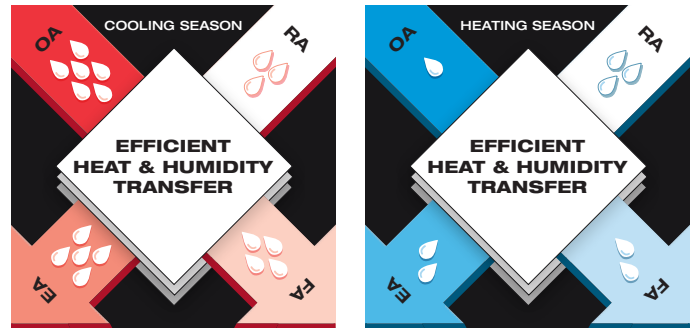

REDUCING HVAC LOADS

RenewAire technology reduces **HVAC loads** during both winter and summer. In turn, HVAC equipment size and needs can be decreased and furnaces and air conditioners can be smaller. This process ensures efficient operations and keeps both energy use and costs low, while at the same time maintaining high-level IAQ.

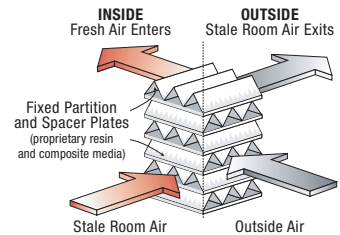

MINIMIZING ENVIRONMENTAL IMPACT

The combination of less energy used and HVAC loads being reduced conserves resources. Further, our Madison, WI plant is 100% powered by renewable wind energy, and is one of the few buildings worldwide to be LEED and Green Globes certified, as well as having achieved ENERGY STAR Building status. This commitment to sustainable manufacturing minimizes our overall production and distribution environmental footprint.



WHY RENEWAIRE IS PREFERRED



BEST VALUE

- Priced competitively against other ERV models
- Due to competitive pricing and decreased costs, payback is short and ROI is maximized
- Contractors can pass these significant savings along to their customers



RELIABLE OPERATION

- Built-to-last ERVs have lifespans of 25+ years and operate consistently year-round in every extreme, including frost-free performance in all but the most severe winter climates
- High-efficiency core operates dry in all conditions, meaning no condensate pans
- An industry-leading ten-year warranty for the static-plate core, two-year warranty for commercial products and a five-year warranty for residential products
- Superior product quality results in paramount reliability and longevity



HIGHEST-QUALITY INDOOR AIR

- Stale indoor air is replaced with fresh, conditioned and filtered air from the outside, resulting in Enhanced IAQ by removing harmful contaminants
- Airstreams do not mix and pollutants are not transferred across partition plates
- No biocide used; material does not promote biological growth
- Moderated temperatures and humidity maintain a comfortable indoor environment



OPTIMIZED ENERGY EFFICIENCY

- Efficient heat and humidity transfer recaptures up to 70-80% of the energy exhausted in the airstream
- Energy that's otherwise wasted by conventional ventilation systems (such as bath fans) is reused, thus dramatically reducing monthly operation costs
- Energy-efficient operation decreases HVAC loads, which cuts down on energy use and costs
- The hotter or colder the climate, the more energy is recovered



HIGHLY CERTIFIED

- See individual catalog submittal for certification details:
 - UL
 - cUL
 - ETL
 - HVI
 - AHRI



CA INDOOR

Energy Recovery Module



INDOOR UNIT Modular Cabinets

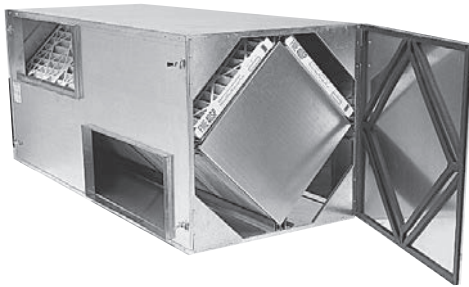

Download specification at:
renewaire.com/specifications

SPECIFICATIONS

Ventilation Type:
Static plate, heat and humidity transfer

Standard Features:
Insulated sheet metal cabinets with energy exchange cores and filters.
Individual CA-Series units or stacks of units can be built into larger air handling systems.
Blower not included and must be specified to meet job requirements.

Insulation:
One inch, high density, FSK faced, fiberglass

Options:
Double wall construction
Exterior paint - white, custom colors

Accessories:
Filters - MERV 13, 2" (shipped loose)

Description	CA2XIN	CA3XIN	CA4XIN
Typical Airflow Range CFM	500-2,200	750-3,300	1,000-4,400
AHRI 1060 Certified Core	Two L125-G5	Three L125-G5	Four L125-G5
Unit Dimensions & Weight	36" L x 42 1/2" W x 35" H 225-304 lbs.	36" L x 62 1/4" W x 35" H 325-430 lbs.	36" L x 81 3/4" W x 35" H 400-531 lbs.
Max. Shipping Dimensions & Weight (on pallet)	62" L x 42" W x 40" H 350 lbs.	70" L x 47" W x 40" H 500 lbs.	96" L x 47" W x 40" H 620 lbs.
Filters: MERV 8: 20" x 20" x 2"	Total qty. 4	Total qty. 6	Total qty. 8

AIRFLOW PERFORMANCE

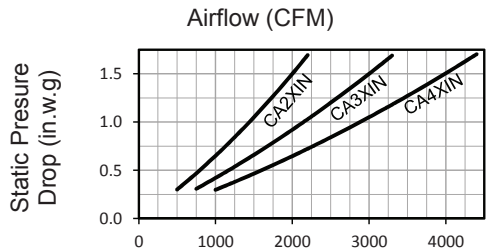

Note: Airflow performance includes effect of clean, standard filter supplied with unit.

APPLICATION

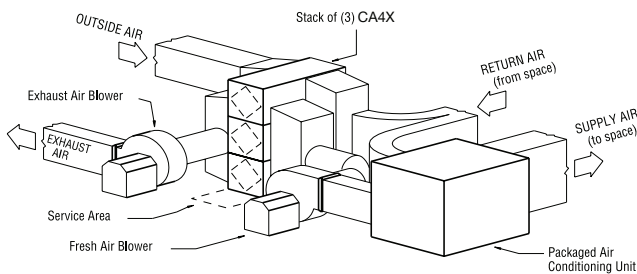

Specifications may be subject to change without notice.

CA2XIN Energy Recovery Module

ABBREVIATION
 EA: Exhaust Air to outside
 OA: Outside Air intake
 RA: Room Air to be exhausted
 FA: Fresh Air to inside

INSTALLATION ORIENTATION
 Unit may be installed in any orientation.

NOTE:
 1. UNLESS OTHERWISE SPECIFIED, DIMENSIONS ARE ROUNDED TO THE NEAREST EIGHTH OF AN INCH.
 2. SPECIFICATIONS MAY BE SUBJECT TO CHANGE WITHOUT NOTICE.

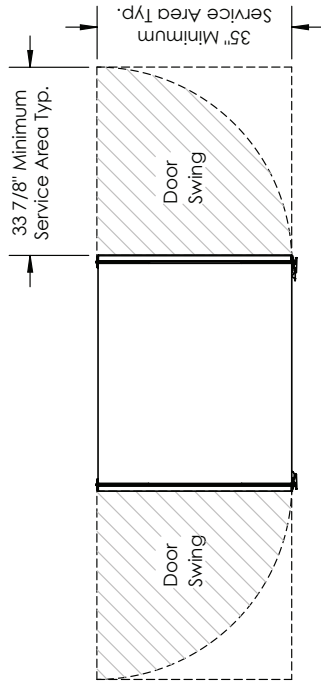

TOP VIEW

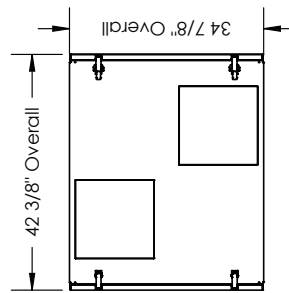

LEFT VIEW

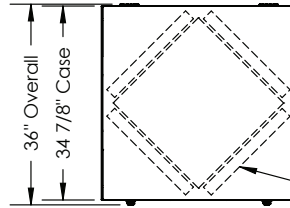

Note: Pleated, disposable 20" X 20" X 2" filters are provided for installation and are interchangeable based on your airflow path requirements. Filters are to be mounted upstream to the core in the direction of airflow entering the unit.

FRONT VIEW

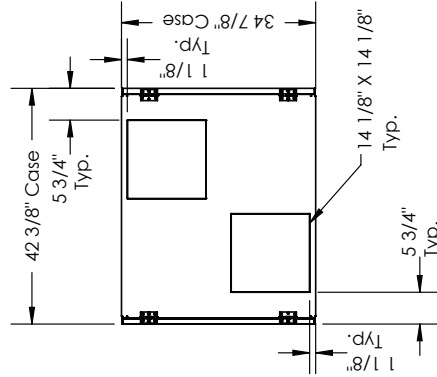

RIGHT VIEW

AIRFLOW CONFIGURATION
 Available as shown in dimension drawing.

UNIT MOUNTING & APPLICATION
 Can be mounted in any orientation. RA/EA airstream can be switched with OA/FA airstream. Can be stacked three high.

CA3XIN Energy Recovery Module

ABBREVIATION

- EA: Exhaust Air to outside
- OA: Outside Air intake
- RA: Room Air to be exhausted
- FA: Fresh Air to inside

INSTALLATION ORIENTATION

Unit may be installed in any orientation.

NOTE:

1. UNLESS OTHERWISE SPECIFIED, DIMENSIONS ARE ROUNDED TO THE NEAREST EIGHTH OF AN INCH.
2. SPECIFICATIONS MAY BE SUBJECT TO CHANGE WITHOUT NOTICE.

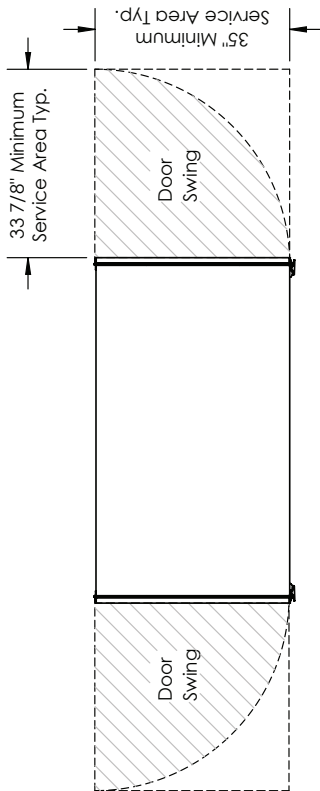

TOP VIEW

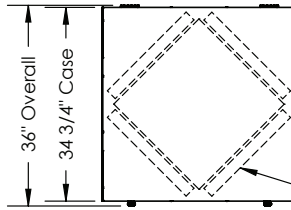

Note: Pleated, disposable 20" X 20" X 2" filters are provided for installation and are interchangeable based on your airflow path requirements. Filters are to be mounted upstream to the core in the direction of airflow entering the unit.

FRONT VIEW

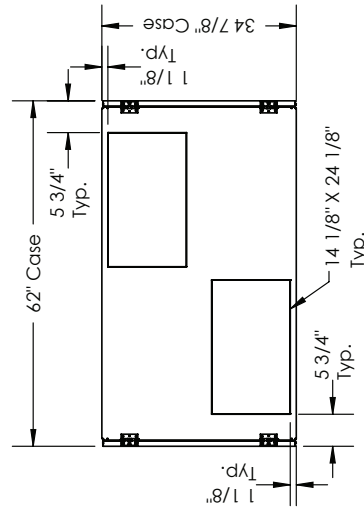

RIGHT VIEW

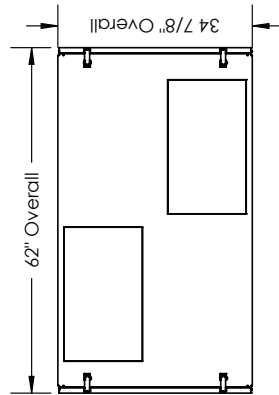

LEFT VIEW



AIRFLOW CONFIGURATION
Available as shown in dimension drawing.



UNIT MOUNTING & APPLICATION
Can be mounted in any orientation. RA/EA airstream can be switched with OA/FA airstream. Can be stacked three high.

CA4XIN Energy Recovery Module

ABBREVIATION
 EA: Exhaust Air to outside
 OA: Outside Air intake
 RA: Room Air to be exhausted
 FA: Fresh Air to inside

INSTALLATION ORIENTATION
 Unit may be installed in any orientation.

NOTE:
 1. UNLESS OTHERWISE SPECIFIED, DIMENSIONS ARE ROUNDED TO THE NEAREST EIGHTH OF AN INCH.
 2. SPECIFICATIONS MAY BE SUBJECT TO CHANGE WITHOUT NOTICE.

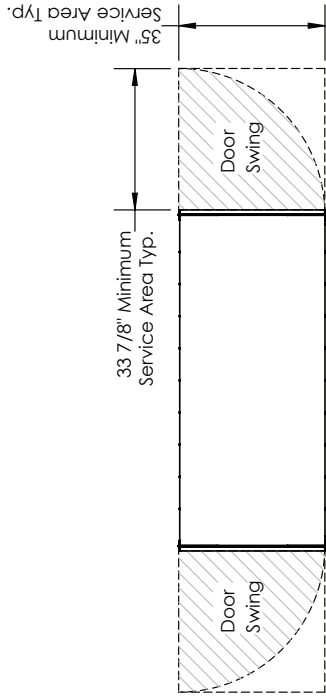

TOP VIEW

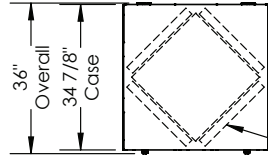

Note: Pleated, disposable 20" X 20" X 2" filters are provided for installation and are interchangeable and are interchangeable based on your airflow path requirements. Filters are to be mounted upstream to the core in the direction of airflow entering the unit.

FRONT VIEW

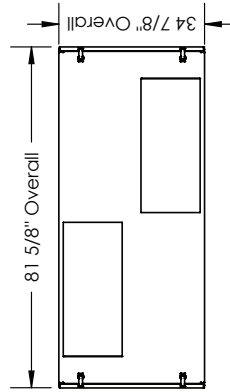

LEFT VIEW

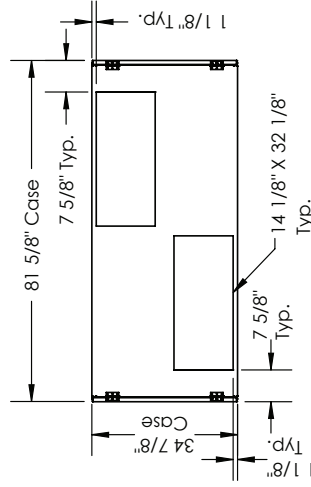

RIGHT VIEW

AIRFLOW CONFIGURATION
 Available as shown in dimension drawing.

UNIT MOUNTING & APPLICATION
 Can be mounted in any orientation. RA/EA airstream can be switched with OA/FA airstream. Can be stacked three high.



CA OUTDOOR Energy Recovery Module



ROOFTOP UNITS Modular Cabinets

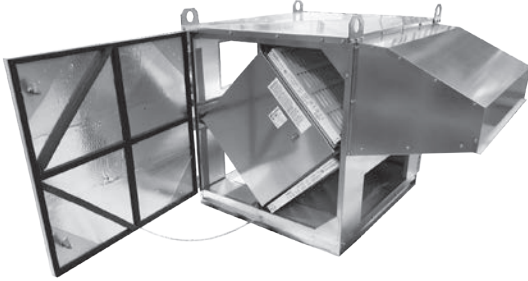

Download specification at:
renewaire.com/specifications

SPECIFICATIONS

Ventilation Type:
Static plate, heat and humidity transfer

Standard Features:
Insulated sheet metal cabinets with energy exchange cores and filters.
Blower not included and must be specified to meet job requirements.

Insulation:
One inch, high density, FSK faced, fiberglass

Options:
Double wall construction
Exterior paint - white, custom colors

Accessories:
Roof curb - standard 14"
Filters - MERV 13, 2" (shipped loose)

Description	CA2XRT	CA3XRT	CA4XRT
Typical Airflow Range CFM	500-2,200	750-3,300	1,000-4,400
AHRI 1060 Certified Core	Two L125-G5	Three L125-G5	Four L125-G5
Unit Dimensions & Weight	55 1/2" L x 43 1/4" W x 42 1/4" H 250-329 lbs.	55 1/2" L x 63 1/2" W x 42 1/2" H 377-482 lbs.	55 1/2" L x 83 1/4" W x 42 1/4" H 462-593 lbs.
Max. Shipping Dimensions & Weight (on pallet)	63" L x 47" W x 48" H 400 lbs.	60" L x 90" W x 48" H 590 lbs.	60" L x 90" W x 48" H 700 lbs.
Filters: MERV 8: 20" x 20" x 2"	Total qty. 4	Total qty. 6	Total qty. 8

AIRFLOW PERFORMANCE

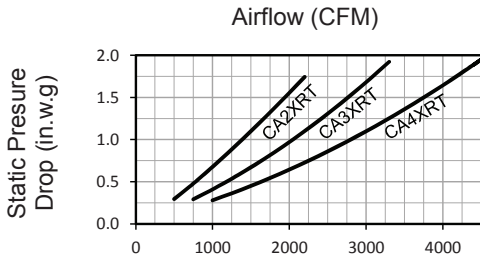

Note: Airflow performance includes effect of clean, standard filter supplied with unit.

Alternate Hood Location, if hood location switched, plug existing mounting holes on opposite side of unit to prevent leakage.

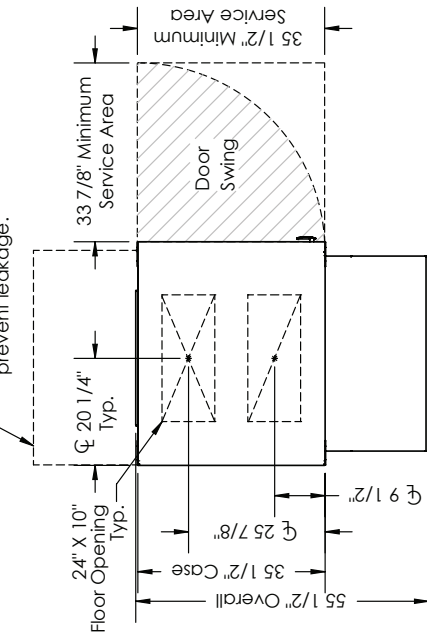

CURB CA2XRT

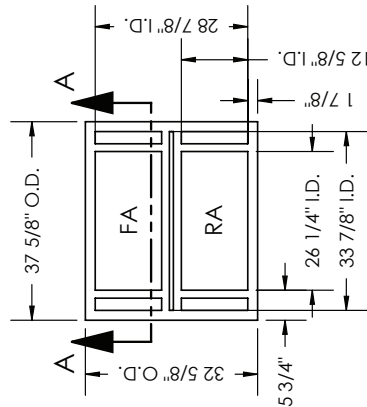

TOP VIEW

TOP VIEW

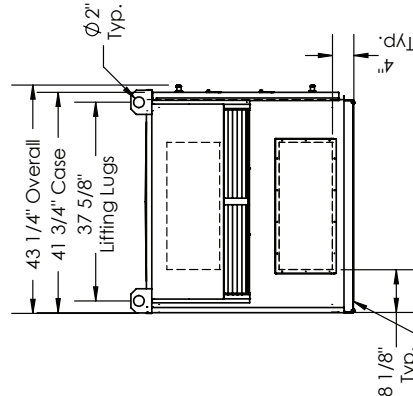

LEFT VIEW

Floor pan inlets/outlets are open by default; These can be patched from inside the unit with removable insulated pans from the side openings, if unused.

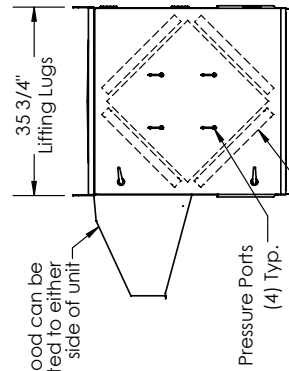

FRONT VIEW

Note: Pleated, disposable 20" X 20" X 2" filters are provided for installation and are interchangeable based on your airflow path requirements. Filters are to be mounted upstream to the core in the direction of airflow entering the unit.

ABBREVIATIONS

- EA: Exhaust Air to outside
- OA: Outside Air Intake
- RA: Room Air to be exhausted
- FA: Fresh Air to inside

INSTALLATION ORIENTATION

Unit must be installed in orientation shown.

NOTE

1. UNLESS OTHERWISE SPECIFIED, DIMENSIONS ARE ROUNDED TO THE NEAREST EIGHTH OF AN INCH.
2. SPECIFICATIONS MAY BE SUBJECT TO CHANGE WITHOUT NOTICE.

CURB CROSS-SECTION A-A (TYP.)

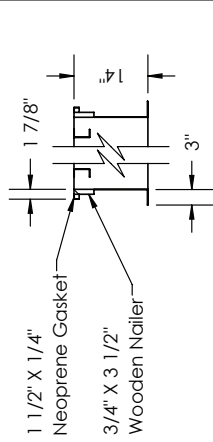

SECTION A-A

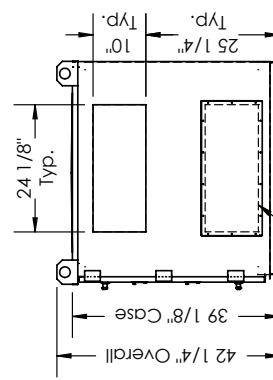

RIGHT VIEW

Lower side pan inlets/outlets are patched with removable insulated pans.

AIRFLOW CONFIGURATION

Available as shown in dimension drawing.

UNIT MOUNTING & APPLICATION

Must be mounted as shown. Duct configuration is field convertible. Weather hood can be moved in the field. RA/EA airstream can be switched with OAVFA airstream.



CA3XRT Energy Recovery Module

Alternate Hood Location. If hood location switched, plug existing mounting holes on opposite side of unit to prevent leakage.

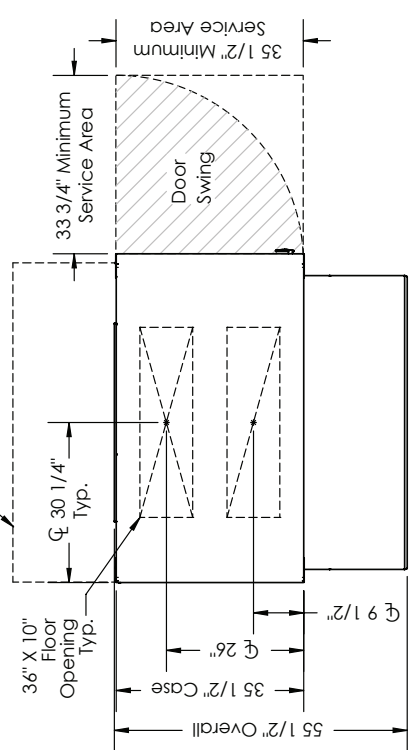

CURB CA3XRT

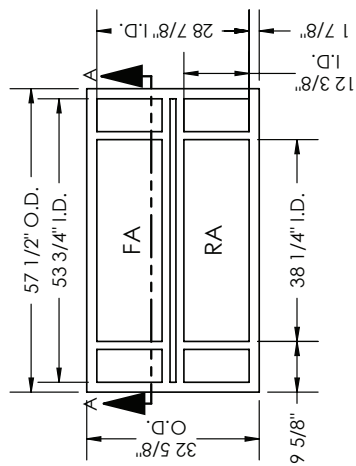

TOP VIEW

ABBREVIATIONS

- EA: Exhaust Air to outside
- OA: Outside Air intake
- RA: Room Air to be exhausted
- FA: Fresh Air to inside

INSTALLATION ORIENTATION

Unit must be installed in orientation shown.

NOTE

- UNLESS OTHERWISE SPECIFIED, DIMENSIONS ARE ROUNDED TO THE NEAREST EIGHTH OF AN INCH.
- SPECIFICATIONS MAY BE SUBJECT TO CHANGE WITHOUT NOTICE.

CURB CROSS-SECTION A-A (TYP.)

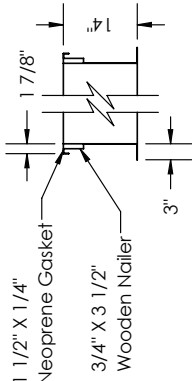

SECTION A-A

TOP VIEW

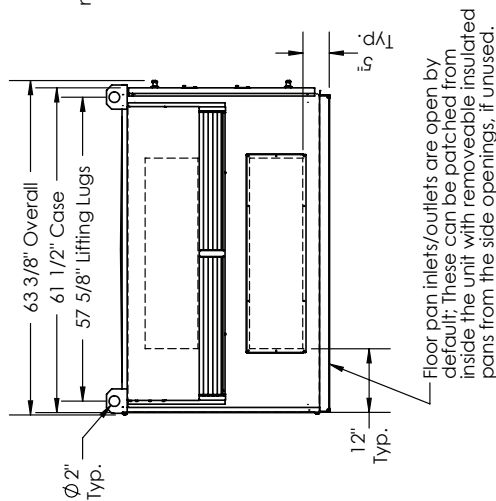

LEFT VIEW

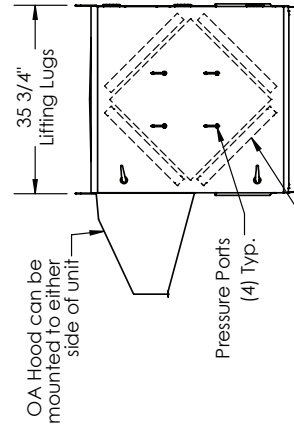

FRONT VIEW

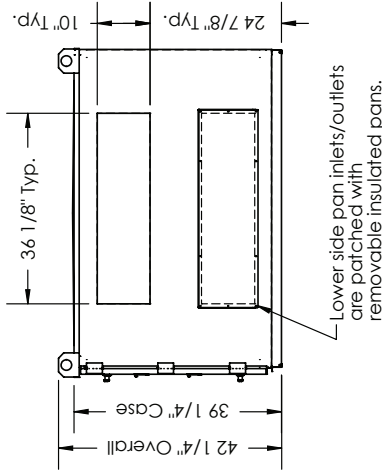

RIGHT VIEW

Note: Pleated, disposable 20" X 20" X 2" filters are provided for installation and are interchangeable based on your airflow path requirements. Filters are to be mounted upstream to the core in the direction of airflow entering the unit.

AIRFLOW CONFIGURATION

Available as shown in dimension drawing.



UNIT MOUNTING & APPLICATION
Must be mounted as shown. Duct configuration is field convertible. Weather hood can be moved in the field. RA/EA airstream can be switched with OA/FA airstream.

CA4XRT Energy Recovery Module

ABBREVIATIONS

- EA: Exhaust Air to outside
- OA: Outside Air intake
- RA: Room Air to be exhausted
- FA: Fresh Air to inside

INSTALLATION ORIENTATION

Unit must be installed in orientation shown.

NOTE

1. UNLESS OTHERWISE SPECIFIED, DIMENSIONS ARE ROUNDED TO THE NEAREST EIGHTH OF AN INCH.
2. SPECIFICATIONS MAY BE SUBJECT TO CHANGE WITHOUT NOTICE.

Alternate Hood Location, if hood location switched, plug existing mounting holes on opposite side of unit to prevent leakage.

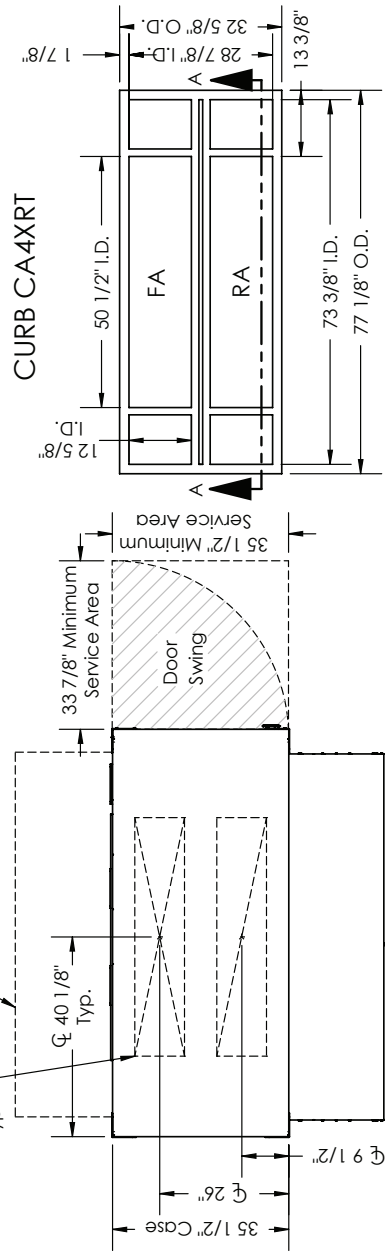

TOP VIEW

TOP VIEW

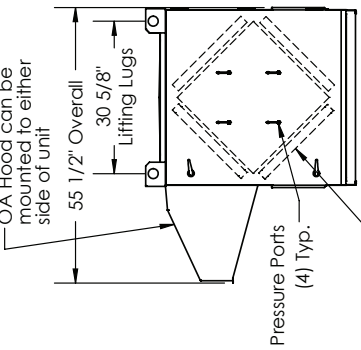
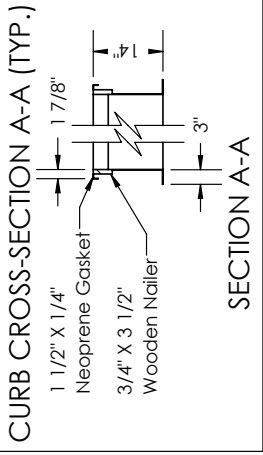

FRONT VIEW

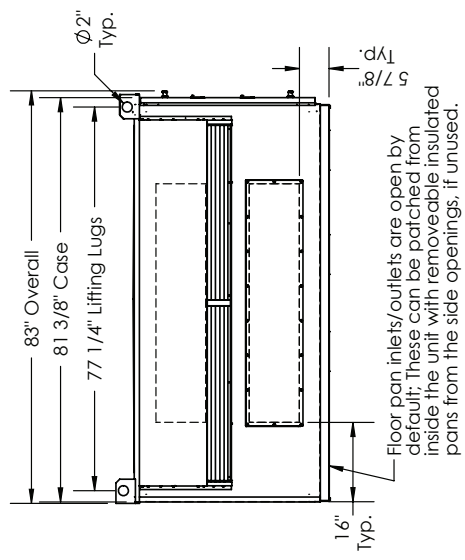

LEFT VIEW

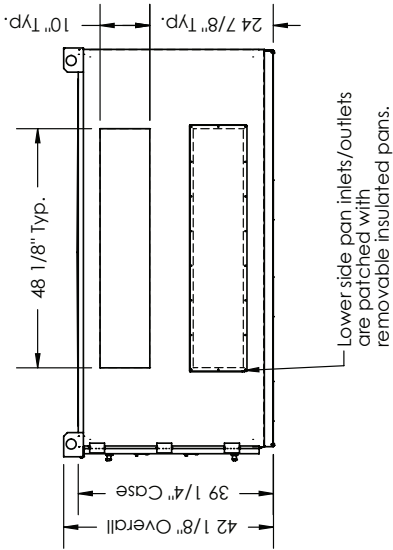

RIGHT VIEW

AIRFLOW CONFIGURATION

Available as shown in dimension drawing.

UNIT MOUNTING & APPLICATION

Must be mounted as shown. Duct configuration is field convertible. Weather hood can be moved in the field. RA/EA airstream can be switched with OAVFA airstream.

PA SERIES

Energy Recovery Module



INDOOR UNIT

Unlimited Modular Panels



Download specification at:
renewaire.com/specifications

SPECIFICATIONS

Ventilation Type:

Static plate, heat and humidity transfer

Standard Features:

Insulated sheet metal panels easily slide into receivers to enclose stacks of energy exchange cores using unique patented design, US Patent 5,660,228

Individual PA-Series units can be joined together to provide unlimited airflow capacities for larger air handling systems.

Blower not included and must be specified to meet job requirements.

Insulation:

One inch, high density, FSK faced, fiberglass

Options:

Knockdown

Assembled on structural forklift base

Accessories:

Filters - MERV 13, 2" (shipped loose)

Description	PA6X	PA8X	PA9X	PA12X
Typical Airflow Range CFM	1,500-6,600	2,000-8,800	2,250-9,900	3,000-13,200
AHRI 1060 Certified Core	Six L125-G5	Eight L125-G5	Nine L125-G5	Twelve L125-G5
Unit Dimensions & Weight	73 1/2" L x 37 1/4" W x 66 1/4" H 522-565 lbs.	73 1/2" L x 37 1/4" W x 86" H 650-700 lbs.	109 1/2" L x 37 1/4" W x 66 1/4" H 740-910 lbs.	109 1/2" L x 37 1/4" W x 86" H 936-1,000 lbs.
Max. Shipping Dimensions & Weight (on pallet, assembled only)	96" L x 47" W x 75" H 700 lbs.	96" L x 47" W x 92" H 850 lbs.	124" L x 48" W x 75" H 1,100 lbs.	124" L x 48" W x 95" H 1,200 lbs.
Filters MERV 8: 20" x 20" x 2"	Total qty. 12	Total qty. 16	Total qty. 18	Total qty. 24

AIRFLOW PERFORMANCE

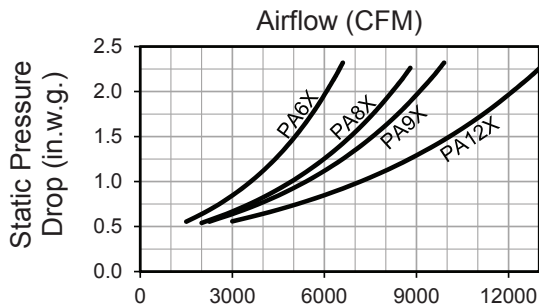

Note: Airflow performance includes effect of clean, standard filter supplied with unit.

PA6X Energy Recovery Module

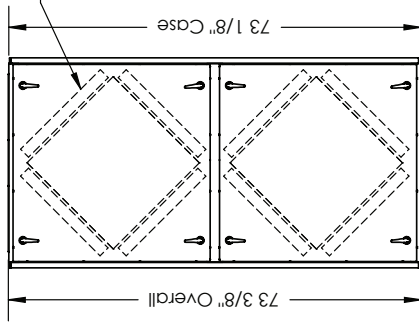

TOP VIEW

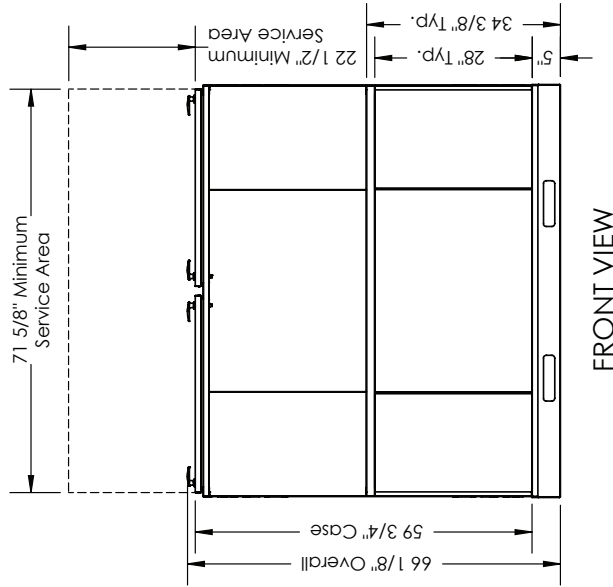

FRONT VIEW

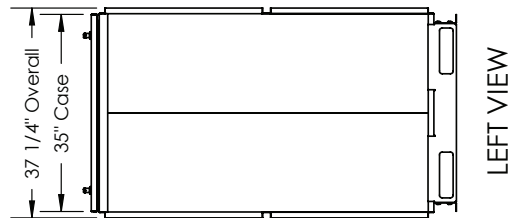

LEFT VIEW

ABBREVIATION

- EA: Exhaust Air to outside
- OA: Outside Air intake
- RA: Room Air to be exhausted
- FA: Fresh Air to inside

INSTALLATION ORIENTATION

Unit must be installed in orientation shown.

NOTE:

1. UNLESS OTHERWISE SPECIFIED, DIMENSIONS ARE ROUNDED TO THE NEAREST EIGHTH OF AN INCH.
2. SPECIFICATIONS MAY BE SUBJECT TO CHANGE WITHOUT NOTICE.

AVAILABLE AIRFLOW ARRANGEMENTS (SIDE VIEW)

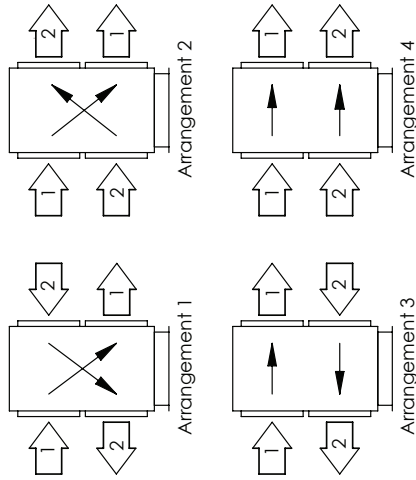

Performance Derating:

Airflow Arrangements 3 & 4 result in lower energy transfer. Reduce sensible effectiveness by 2 percentage points. Reduce total effectiveness by 1 percentage point.

AIRFLOW CONFIGURATION

Available as shown:

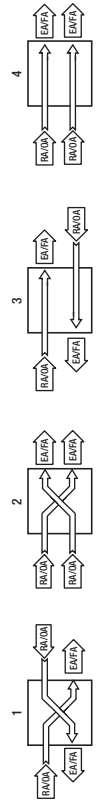

UNIT MOUNTING & APPLICATION

Must be mounted as shown. RA/EA airstream can be switched with OA/FA airstream. Knockdown can be field assembled for multiple duct configurations. Multiple cabinets can be aligned for unlimited airflow.

PA8X Energy Recovery Module

ABBREVIATION
 EA: Exhaust Air to outside
 OA: Outside Air intake
 RA: Room Air to be exhausted
 FA: Fresh Air to inside

INSTALLATION ORIENTATION
 Unit must be installed in orientation shown.

NOTE:
 1. UNLESS OTHERWISE SPECIFIED, DIMENSIONS ARE ROUNDED TO THE NEAREST EIGHTH OF AN INCH.
 2. SPECIFICATIONS MAY BE SUBJECT TO CHANGE WITHOUT NOTICE.

Filters to be placed on the upstream side of the cores, depending on airflow arrangement chosen. Filters are 2" X 20" X 20" pleated disposable.

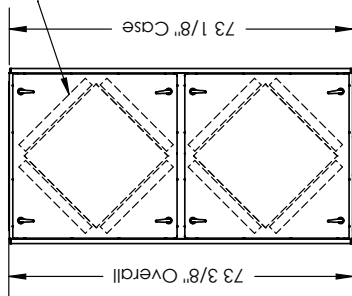

TOP VIEW

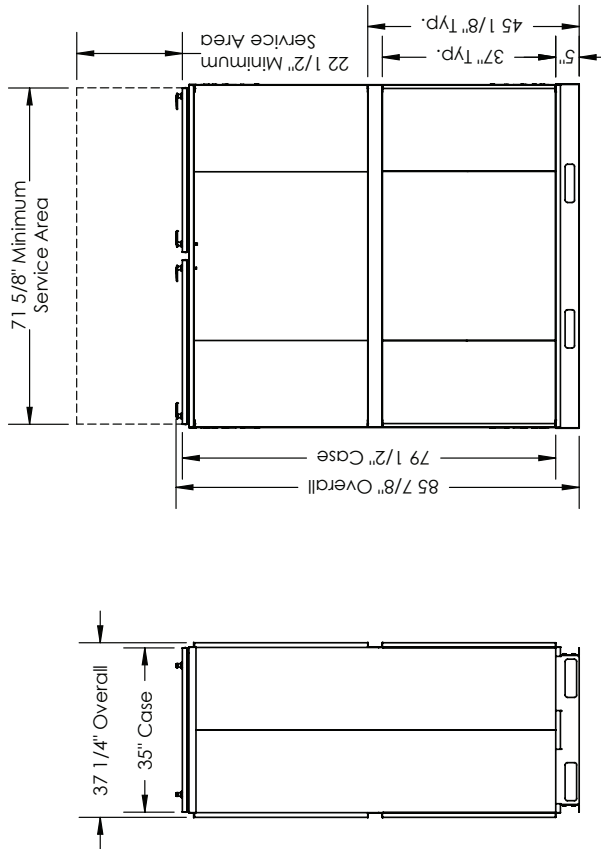

LEFT VIEW

AVAILABLE AIRFLOW ARRANGEMENTS (SIDE VIEW)

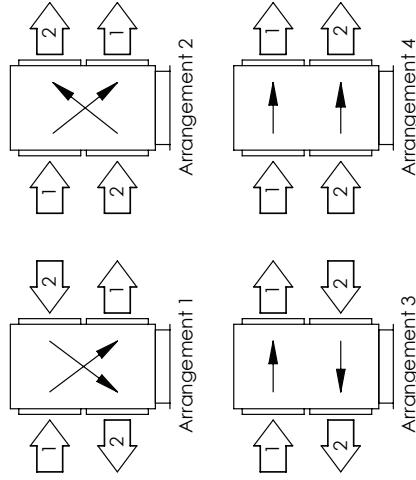

Performance Derating:
 Airflow Arrangements 3 & 4 result in lower energy transfer.
 Reduce sensible effectiveness by 2 percentage points.
 Reduce total effectiveness by 1 percentage point.

AIRFLOW CONFIGURATION

Available as shown:

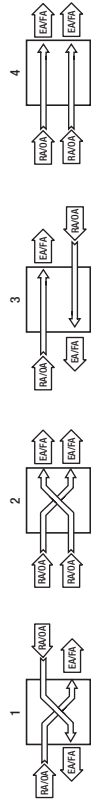

UNIT MOUNTING & APPLICATION
 Must be mounted as shown. RA/EA airstream can be switched with OA/FA airstream. Knockdown can be field assembled for multiple duct configurations. Multiple cabinets can be aligned for unlimited airflow.



PA9X Energy Recovery Module

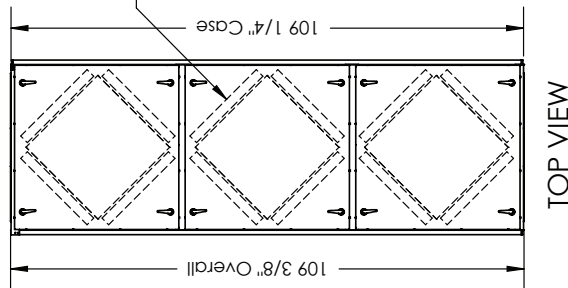

ABBREVIATION
 EA: Exhaust Air to outside
 OA: Outside Air intake
 RA: Room Air to be exhausted
 FA: Fresh Air to inside

INSTALLATION ORIENTATION
 Unit must be installed in orientation shown.

NOTE:
 1. UNLESS OTHERWISE SPECIFIED, DIMENSIONS ARE ROUNDED TO THE NEAREST EIGHTH OF AN INCH.
 2. SPECIFICATIONS MAY BE SUBJECT TO CHANGE WITHOUT NOTICE.

AVAILABLE AIRFLOW ARRANGEMENTS (SIDE VIEW)

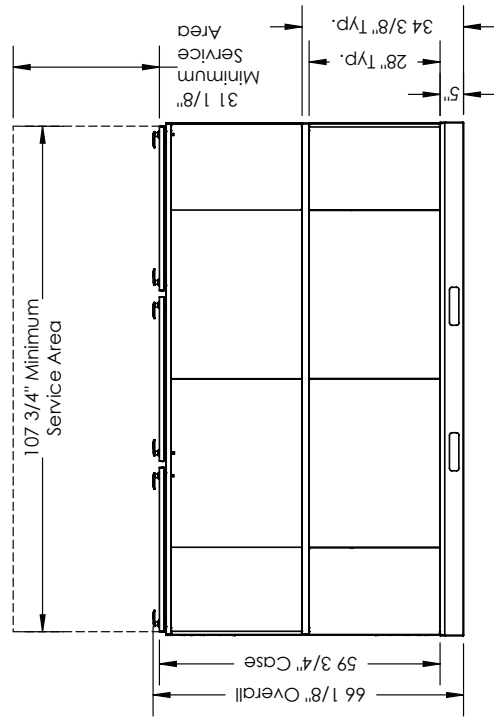
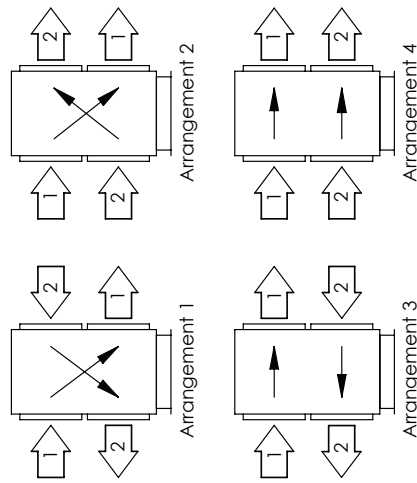

FRONT VIEW

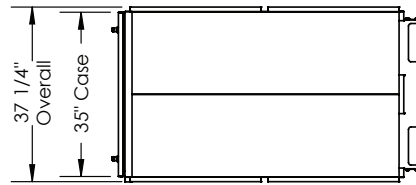

LEFT VIEW

Performance Derating:
 Airflow Arrangements 3 & 4 result in lower energy transfer.
 Reduce sensible effectiveness by 2 percentage points.
 Reduce total effectiveness by 1 percentage point.

AIRFLOW CONFIGURATION

Available as shown:

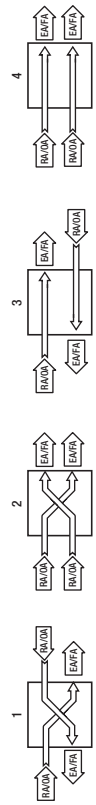

UNIT MOUNTING & APPLICATION
 Must be mounted as shown. RA/EA airstream can be switched with OA/FA airstream. Knockdown can be field assembled for multiple duct configurations. Multiple cabinets can be aligned for unlimited airflow.



PA12X Energy Recovery Module

ABBREVIATION
 EA: Exhaust Air to outside
 OA: Outside Air intake
 RA: Room Air to be exhausted
 FA: Fresh Air to inside

INSTALLATION ORIENTATION
 Unit must be installed in orientation shown.

NOTE:
 1. UNLESS OTHERWISE SPECIFIED, DIMENSIONS ARE ROUNDED TO THE NEAREST EIGHTH OF AN INCH.
 2. SPECIFICATIONS MAY BE SUBJECT TO CHANGE WITHOUT NOTICE.

Filters to be placed on the upstream side of the cores, depending on airflow arrangement chosen. Filters are 2" X 20" X 20" pleated disposable.

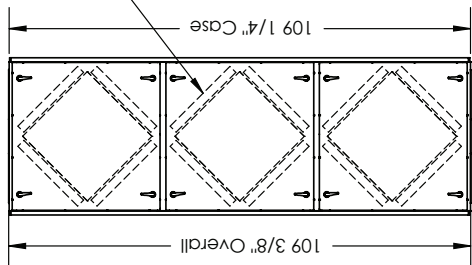

TOP VIEW

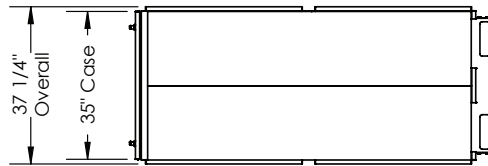

LEFT VIEW

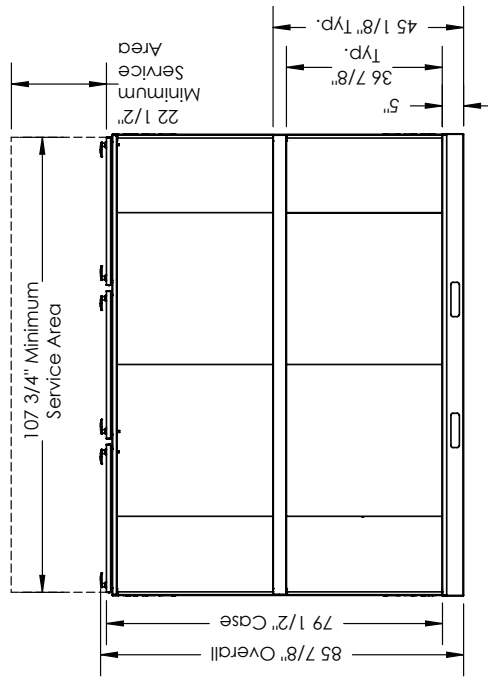

FRONT VIEW

AVAILABLE AIRFLOW ARRANGEMENTS (SIDE VIEW)

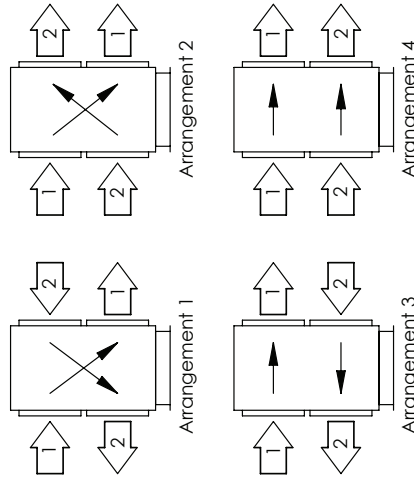

Performance Derating:

Airflow Arrangements 3 & 4 result in lower energy transfer. Reduce sensible effectiveness by 2 percentage points. Reduce total effectiveness by 1 percentage point.



AIRFLOW CONFIGURATION

Available as shown:

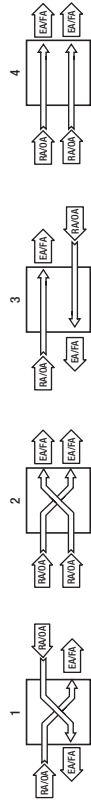

UNIT MOUNTING & APPLICATION
 Must be mounted as shown. RA/EA airstream can be switched with OA/FA airstream. Knockdown can be field assembled for multiple duct configurations. Multiple cabinets can be aligned for unlimited airflow.

THIS PAGE IS INTENTIONALLY LEFT BLANK.



THIS PAGE IS INTENTIONALLY LEFT BLANK.



CA & PA MODEL CONFIGURATION GUIDE

Note: Not all options are available on every model.

MODEL NUMBER						J						-	-	-	-	-	-	-	-	-	-	-	-	N	
DIGIT NUMBER	1	2	3	4	5	6	7	8	9	10	11	12	13	14	15	16	17	18	19	20	21	22	23	24	25

Digits 1 - 2:	Model
"CA-2X" = Cabinet Applied 2 Cores "CA-3X" = Cabinet Applied 3 Cores "CA-4X" = Cabinet Applied 4 Cores "PA-6X" = Panelized Applied 6 Cores "PA-8X" = Panelized Applied 8 Cores "PA-9X" = Panelized Applied 9 Cores "PA12X" = Panelized Applied 12 Cores	

Digits 7 - 8:	Location (see Restriction 1)
"IN" = Indoor "RT" = Rooftop	

Digit 9:	Forklift Base
"-" = None (CA Models) "9" = Forklift Base (PA Models)	

Digit 10:	Orientation (see Restrictions 2 & 3)
"1" = Opposite-side Entry, Cross-flow "2" = Same-side Entry, Cross-flow "3" = Opposite-side Entry, Parallel-flow "4" = Same-side Entry, Parallel-flow "-" = Flexible Airflow	

Digit 11:	Wall Type (see Restriction 4)
"S" = Single "D" = Double	

Digit 24:	Other Options (see Restriction 5, 6 & 7)
"-" = None "K" = Knockdown "A" = Assembled "W" = White Paint "C" = Custom Paint "X" = Custom Unit	

Digit 25:	Safety Listing
"N" = Non-Listed	

***NOTES:**
 Digit 6 "J" = G5 Core Type Digits 12-23 are not used in these models.

Restrictions:
1: Location Code "RT" only available with CA models. 2: Orientation Code "-" only available on CA models & PA models with Flexible Packaging Code "K". 3: Orientation Codes "1", "2", "3", & "4" only available with PA models with Flexible Packaging Code "A". 4: Wall Code "D" only available with CA models. 5: Other Option Codes "W" & "C" only available with CA models. 6: Other Option Code "W" only available with CA models with Location Code "RT". 7: Other Option Codes "A" & "K" only available with PA models.

For Technical Support E-mail: RenewaAirSupport@renewaire.com
 To Place an Order E-mail: RenewaAirOrders@renewaire.com

INDOOR AIR QUALITY MATTERS

- ◆ **Deficient IAQ** is an EPA **top-five** health risk
- ◆ People spend **90%** of their **time indoors**
- ◆ **Indoor air** can be 2-5 times and up to 100 times **more polluted than outdoor air**

BENEFITS OF INCREASED VENTILATION



TECHNICAL/APPLICATIONS SUPPORT

The goal of our technical-support team is to provide the **BEST CUSTOMER SERVICE** in the HVAC industry. You can count on our knowledgeable and seasoned staff for all your technical, application and service needs, and we'll respond quickly and effectively to answer any of your questions.

CONTACT RENEWAIRE



PHONE:
1.800.627.4499
FAX:
608.221.2824



FOR TECHNICAL SUPPORT:
RenewaيرةSupport@renewaيرة.com
TO PLACE AN ORDER:
RenewaيرةOrders@renewaيرة.com

RELEVANT EVERYWHERE

EVERY GEOGRAPHIC REGION

Our ERVs function perfectly across the world in every geographic region.

EVERY CLIMATE

Our ERVs operate in every climate—from Alaska to Florida, and everywhere in between.

EVERY PROJECT

From massive skyscrapers to cozy residential homes, our ERVs can be used in every size project and in every code jurisdiction.

RENEWAIRE
TEMPERS THE AIR



Our ERVs moderate the extremes of outdoor supply-air temperature and humidity year-round, providing a sustainable solution for fresh air that feels like a perfect spring day.

APPLIED EVERYWHERE

When indoor occupants breathe in unclean air, this harms their health and causes cognitive impairment. Our ERVs can provide cleaner and healthier indoor air for every type of building in the world, thus improving occupants' wellbeing, while also reducing energy costs.

RESIDENTIAL

The increased airtightness of newer and remodeled homes is causing deficient IAQ, resulting in more health problems for indoor occupants.

COMMERCIAL

As commercial buildings become more airtight, deficient IAQ is increasing and causing sickness, absenteeism and decreased productivity.

HEALTHCARE

The high occupant density of hospitals, nursing homes and other healthcare facilities results in deficient IAQ and ensuing health problems for patients and staff alike.

RESTAURANTS/COFFEE SHOPS

The large volume of indoor occupants in restaurants and coffee shops causes deficient IAQ and subsequent health problems.

RETAIL

The high level of foot traffic in retail stores leads to deficient IAQ and the potential sickness of shoppers, which can negatively impact sales.

DAYCARE

Crowded daycare facilities breed deficient IAQ, thus causing health problems for everyone—especially children who are more vulnerable.

EDUCATION (LOWER AND HIGHER)

With students and teachers packed into tight classrooms, instances of deficient IAQ go up, resulting in academic performance and test scores going down.

GOVERNMENT

Aging and crowded government buildings result in deficient IAQ, which can impair worker performance and productivity.

EVERY TYPE OF BUILDING

Every type of building can benefit from the enhanced IAQ generated by RenewAire ERVs, including veterinary clinics, nail salons and manufacturing facilities, among others.



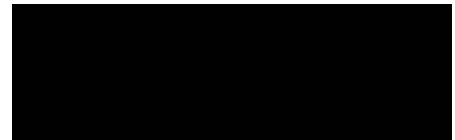
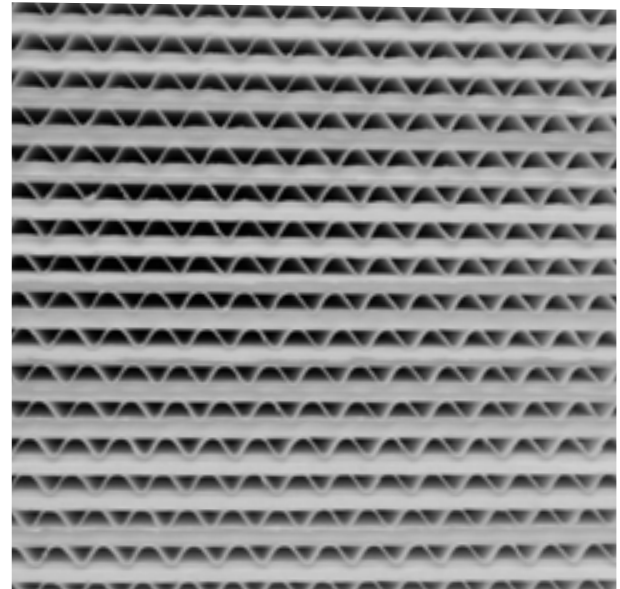

— RENEWAIRE EVERYWHERE —

RenewAire ERVs can be applied everywhere across all commercial, educational, institutional, light industrial and residential buildings. Our technology excels in every geographic region, every climate, and every size project.



Soler&Palau
Ventilation Group

Member of the S&P Group
Family of Brands

 **RenewAire**[®]
Energy Recovery Ventilation



LIT113_01 (12/19)