

# HE SERIES ERV

## Installation, Operation and Maintenance Manual

HE07RT

HE10RT

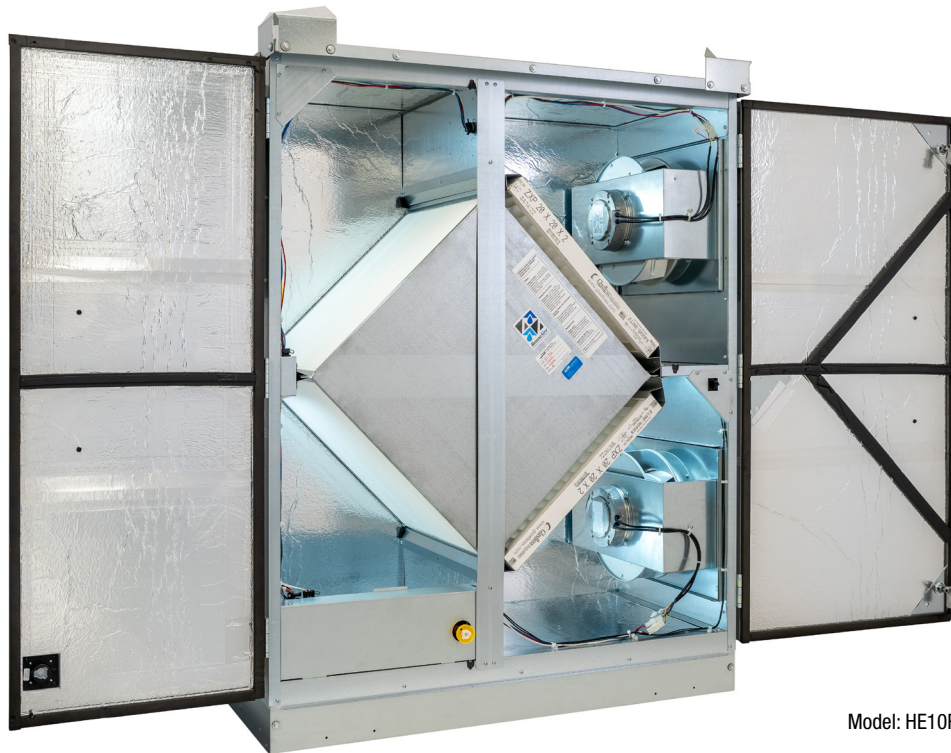

Model: HE10RTH shown



Globally Recognized. Industry Respected.



**⚠ WARNING**

EC motors (ECM) are NOT suitable for use with solid state speed control. They already have speed control built into the motor electronics.

**⚠ AVERTISSEMENT**

Les moteurs EC (ECM) ne conviennent PAS pour une utilisation avec un contrôle de vitesse à semi-conducteurs. Ils ont déjà un contrôle de vitesse intégré à l'électronique du moteur.

**⚠ WARNING****ARC FLASH AND ELECTRIC SHOCK HAZARD**

Arc flash and electric shock hazard. Disconnect all electric power supplies, verify with a voltmeter that electric power is off and wear protective equipment per NFPA 70E before working within electric control enclosure. Failure to comply can cause serious injury or death.

Customer must provide earth ground to unit, per NEC, CEC and local codes, as applicable.

Before proceeding with installation, read all instructions, verifying that all the parts are included and check the nameplate to be sure the voltage matches available utility power.

The line side of the disconnect switch contains live high-voltage.

The only way to ensure that there is NO voltage inside the unit is to install and open a remote disconnect switch and verify that power is off with a volt meter. Refer to unit electrical schematic. Follow all local codes.

**⚠ CAUTION****RISK OF ELECTRIC SHOCK OR EQUIPMENT DAMAGE**

Whenever electrical wiring is connected, disconnected or changed, the power supply to the ERV and its controls must be disconnected. Lock and tag the disconnect switch or circuit breaker to prevent accidental reconnection of electric power.

**⚠ CAUTION****RISK OF CONTACT WITH HIGH SPEED MOVING PARTS**

Disconnect all local and remote power supplies, verify with a voltmeter that electric power is off and all fan blades have stopped rotating before working on the unit.

Do not operate this unit with any cabinet panels removed.

**IMPORTANT**

This equipment is to be installed by following Industry Best Practices and all applicable codes. Any damage to components, assemblies, subassemblies or the cabinet which is caused by improper installation practices will void the warranty.

**IMPORTANT**

This unit is intended for general ventilating and heating only. Do not use to exhaust hazardous or explosive materials and vapors. Do not connect this equipment to range hoods, fume hoods or collection systems for toxics.

**IMPORTANT**

This unit is for ventilating finished structures only. It is not to be used until after all construction has been completed and construction debris and dust are cleaned from the Occupied Space.



<b>1.0 OVERVIEW</b>	<b>7</b>	<b>5.5 WIRING SCHEMATICS</b> .....	<b>21</b>
1.1 DESCRIPTION .....	7	<b>5.6 EXTERNAL CONTROL CONNECTIONS</b> .....	<b>23</b>
1.2 AIRFLOW .....	8	5.6.1 Fan Enable Field Circuit.....	23
<b>2.0 COMPONENT DESCRIPTIONS</b>	<b>10</b>	5.6.2 Fan Speed Selection Field Circuit.....	23
2.1 CABINET .....	10	5.6.3 Fan Speed Adjustment.....	23
2.2 ENTHALPIC CORES .....	10	5.6.4 Analog Signal for Controlling SPEED 2.....	23
2.3 IMPELLER/MOTOR ASSEMBLIES .....	10	<b>5.7 QUICK-START FOR TESTING CORRECT</b>	
2.4 E-BOX .....	10	<b>3PH WIRING</b> .....	<b>23</b>
2.5 FILTERS .....	11	<b>6.0 OPERATION</b>	<b>24</b>
2.6 FACTORY INSTALLED OPTIONS.....	11	<b>6.1 PRINCIPLE OF OPERATION</b> .....	<b>24</b>
<b>3.0 SHIPPING/RECEIVING/HANDLING</b>	<b>12</b>	<b>6.2 PRE-START UP</b> .....	<b>24</b>
<b>3.1 UNIT WEIGHTS AND DIMENSIONS</b> .....	<b>12</b>	6.2.1 Verify Voltages.....	24
3.1.1 HE07RT Unit Dimensions and Weight: .....	12	6.2.2 Verify Transformer Wiring .....	24
3.1.2 HE07RT Maximum Shipping Dimensions and Weight.....	12	6.2.3 Inspect Filters .....	24
3.1.3 HE10RT Unit Dimensions and Weight: .....	12	6.2.4 Inspect Foam Gasketing.....	24
3.1.4 HE10RT Maximum Shipping Dimensions and Weight .....	12	6.2.5 Inspect Fans.....	24
<b>3.2 RIGGING AND CENTER OF GRAVITY</b> .....	<b>13</b>	6.2.6 Inspect and Clean the Cabinet Interior.....	24
3.2.1 HE07RT/HE10RT Hoisting Weights and COG.....	13	6.2.7 Inspect Ductwork Connections.....	24
<b>3.3 RECEIVING</b> .....	<b>13</b>	<b>6.3 UNIT START UP</b> .....	<b>24</b>
<b>3.4 STORAGE</b> .....	<b>14</b>	6.3.1 Starting Up ECM Units.....	24
<b>4.0 UNIT PLACEMENT</b>	<b>14</b>	<b>6.4 BALANCING AIRFLOW</b> .....	<b>25</b>
<b>4.1 BEFORE YOU BEGIN</b> .....	<b>14</b>	6.4.1 Filter Pressure Drop.....	26
<b>4.2 SERVICE CLEARANCES</b> .....	<b>14</b>	<b>6.5 NORMAL OPERATION</b> .....	<b>27</b>
<b>4.3 SOUND ATTENUATION</b> .....	<b>15</b>	<b>6.6 OPERATION IN EXTREME COLD WEATHER</b> .....	<b>27</b>
4.3.1 Outside the Building.....	15	<b>7.0 MAINTENANCE</b>	<b>27</b>
4.3.2 At the Curb.....	15	<b>7.1 MAINTENANCE 24 HRS. AFTER START UP</b> .....	<b>27</b>
4.3.3 Ducts .....	15	<b>7.2 MAINTENANCE 30 DAYS AFTER START UP</b> .....	<b>27</b>
4.3.4 Radiated Noise .....	16	<b>7.3 MAINTENANCE SCHEDULE</b> .....	<b>28</b>
4.3.5 Connecting Horizontal Ducts to Unit .....	16	<b>7.4 FILTERS</b> .....	<b>28</b>
<b>5.0 INSTALLATION</b>	<b>16</b>	<b>7.5 IMPELLER MOTOR</b> .....	<b>28</b>
<b>5.1 CURB SPECIFICATIONS</b> .....	<b>16</b>	<b>7.6 ENTHALPIC CORE</b> .....	<b>28</b>
<b>5.2 DUCTWORK</b> .....	<b>17</b>	7.6.1 Enthalpic Core Maintenance .....	28
5.2.1 Inside Ductwork System .....	17	7.6.2 Enthalpic Core Removal .....	29
5.2.2 Duct Insulation .....	17	7.6.3 Enthalpic Core Replacement.....	29
5.2.3 Adjust Fan Speed to Set and Balance Airflow Rates.....	17	<b>7.7 MAINTENANCE RECORDS</b> .....	<b>29</b>
<b>5.3 INSTALLATION OF HOODS</b> .....	<b>17</b>	<b>7.8 SERVICE PARTS</b> .....	<b>30</b>
5.3.1 Outside Air Hood.....	17	<b>8.0 TROUBLESHOOTING</b>	<b>31</b>
5.3.2 Exhaust Air Hood.....	18	<b>9.0 FACTORY ASSISTANCE</b>	<b>31</b>
<b>5.4 ELECTRICAL REQUIREMENTS</b> .....	<b>19</b>		
5.4.1 Factory-Recommended Electric Service Entry.....	19		
5.4.2 Low Voltage Control System .....	20		
5.4.3 How to Reset the 24VAC Circuit Breaker .....	20		
5.4.4 Limits of Power Output .....	20		

**TABLE OF ILLUSTRATIONS**

Figure 1.2.0 HE07RT Airflow Orientations.....	8
Figure 1.2.1 HE10RT Airflow Orientations.....	9
Figure 2.4.0 HE07RT E-Box Without Controls.....	10
Figure 2.4.1 HE10RT E-Box Without Controls.....	11
Figure 3.2.0 HE07RT Weights and COG.....	13
Figure 3.2.1 HE10RT Weights and COG.....	13
Figure 4.2.0 HE07RT Service Clearances, Top View.....	14
Figure 4.2.1 HE10RT Service Clearances, Top View.....	15
Figure 5.3.0 Outside Air Screw Locations.....	17
Figure 5.3.1 Outside Air Hood (Typical).....	18
Figure 5.3.2 Exhaust Air Screw Locations.....	18
Figure 5.3.3 Exhaust Air Hood (Typical).....	18
Figure 5.4.0 HE07RT E-Box Wiring Entry Points.....	19
Figure 5.4.1 HE10RT E-Box Wiring Entry Points.....	19
Figure 5.5.0 Single Phase Unit, Standard.....	21
Figure 5.5.1 Three Phase Unit, Standard (HE10RT Only).....	22
Figure 5.6.0 Field Circuit Detail.....	23
Figure 6.4.0 Pressure Port Locations.....	25
Figure 6.4.1 Initial Pressure Drop of MERV 8 Filters, Supplied with HE07.....	26
Figure 6.4.2 Initial Pressure Drop of MERV 13 Filters, Available as an HE07 Accessory.....	26
Figure 6.4.3 Initial Pressure Drop of MERV 8 Filters, Supplied with HE10.....	26
Figure 6.4.4 Initial Pressure Drop of MERV 13 Filters, Available as an HE10 Accessory.....	27
Figure 7.8.0 HE07RT Service Parts.....	30
Figure 7.8.1 HE10RT Service Parts.....	31



## 1.0 OVERVIEW

### 1.1 DESCRIPTION

The HE07RT/HE10RT Energy Recovery Ventilator (ERV) is a device for recovering both sensible energy (heat) and latent energy (moisture) from the Exhaust Air from an Occupied Space and injecting those energies into an incoming Outside Air stream. It accomplishes this task by forcing the two airstreams through enthalpic cores, where the energy exchange takes place. The two airstreams pass through the enthalpic cores at right angles and the airstreams never mix together. See Section 2.2 Enthalpic Cores in this manual.

Each ERV has two electric impellers, one for each airstream. Impellers have electronically commutated motors controlled by a printed circuit board, a RenewAire Commercial Controller, or by a BMS. There are a number of different control devices available to control the operation or speed of the unit fans. For further information on available control accessories, see the HE RenewAire catalog.

There are two types of HE07/HE10 units, one for indoor installations and one for rooftop, or outdoor, installation. This manual is for the HE07RT/HE10RT, which is the outdoor unit. For information on the indoor version of this product, see the *HE07IN/HE10IN Installation and Operation Manual*.

HE07RT/HE10RT units are designed to be installed outdoors, mounted on either a factory-supplied curb or on owner-supplied rails.

These ERVs are commonly installed as part of an air-handling system that provides heating and cooling of Supply Air. They can also be installed to operate as stand-alone devices when ducted directly to and from the Occupied Space.

Each unit has an integral 24VAC power supply that is used internally and can also be used as a power source for other optional control devices.

The HE07RT/HE10RT units are low-maintenance, requiring periodic replacement of the air filters and annual vacuuming of the enthalpic cores. See Section 7.0 Unit Maintenance in this manual.

#### IMPORTANT

It is important to understand and use the equipment airstream terminology as it is used in this manual. The airstreams are defined as:

- ♦ OUTSIDE AIR (OA): Air taken from the external atmosphere and, therefore, not previously circulated through the system.
- ♦ SUPPLY AIR (SA): Air that is downstream of the enthalpic cores and is ready for conditioning or for return to the Occupied Space.
- ♦ RETURN AIR (RA): Air that is returned to the ERV from a conditioned space.
- ♦ EXHAUST AIR (EA): Air that is removed from a heating or cooling appliance or from the Occupied Space and discharged.

### 1.2 AIRFLOW

There are four different airflow options for the HE07RT. They are:

- HE07RTV
- HE07RTR
- HE07RTF
- HE07RTH

All four configurations include attached hoods for the OA and EA airstreams. The airflow configuration is indicated by digit 9 of the Configuration Code.

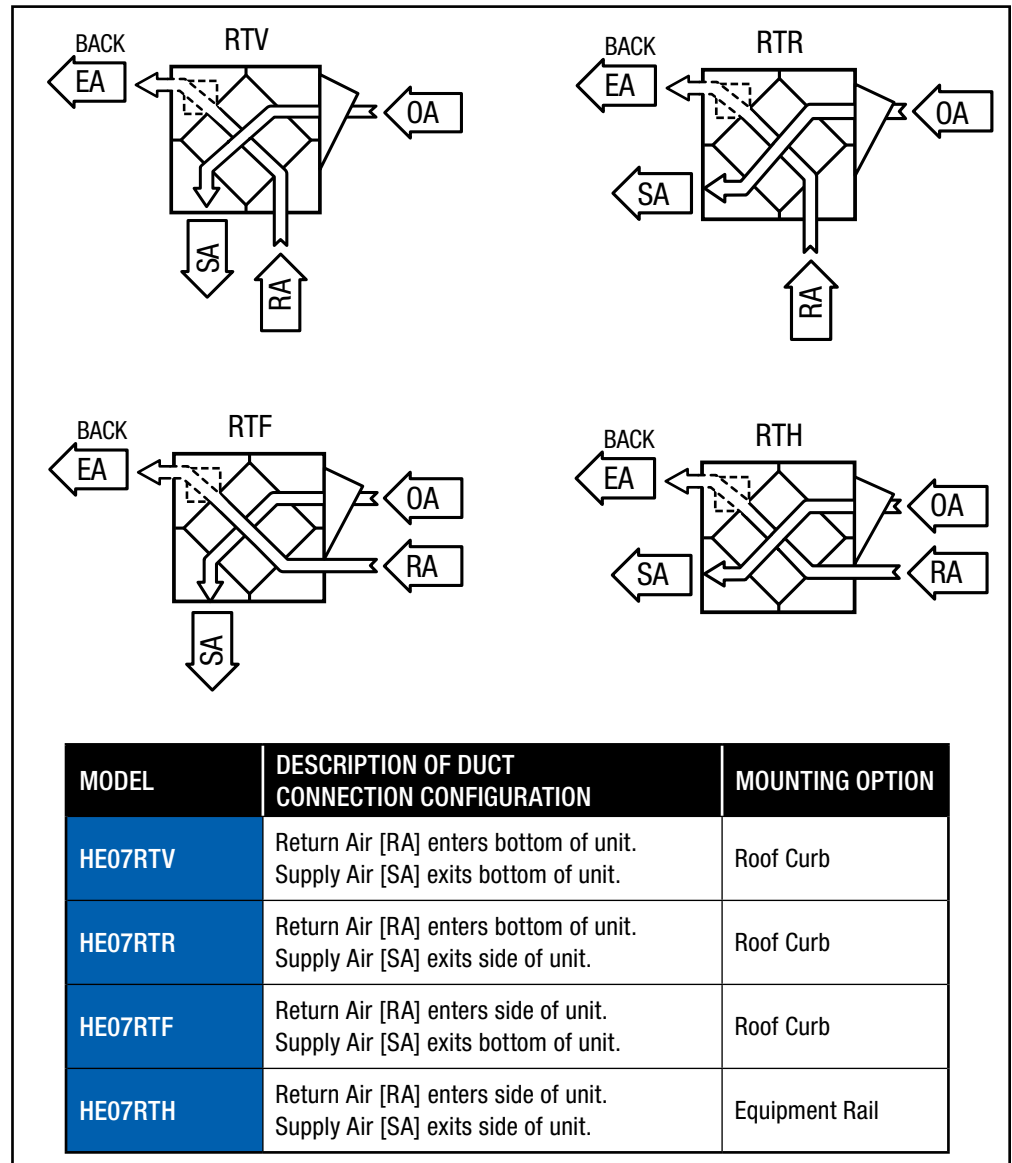

FIGURE 1.2.0 HE07RT AIRFLOW ORIENTATIONS



There are four different airflow options for the HE10RT. They are:

- HE10RTV
- HE10RTR
- HE10RTF
- HE10RTH

All four configurations include attached hoods for the OA and EA airstreams. The airflow configuration is indicated by digit 9 of the Configuration Code.

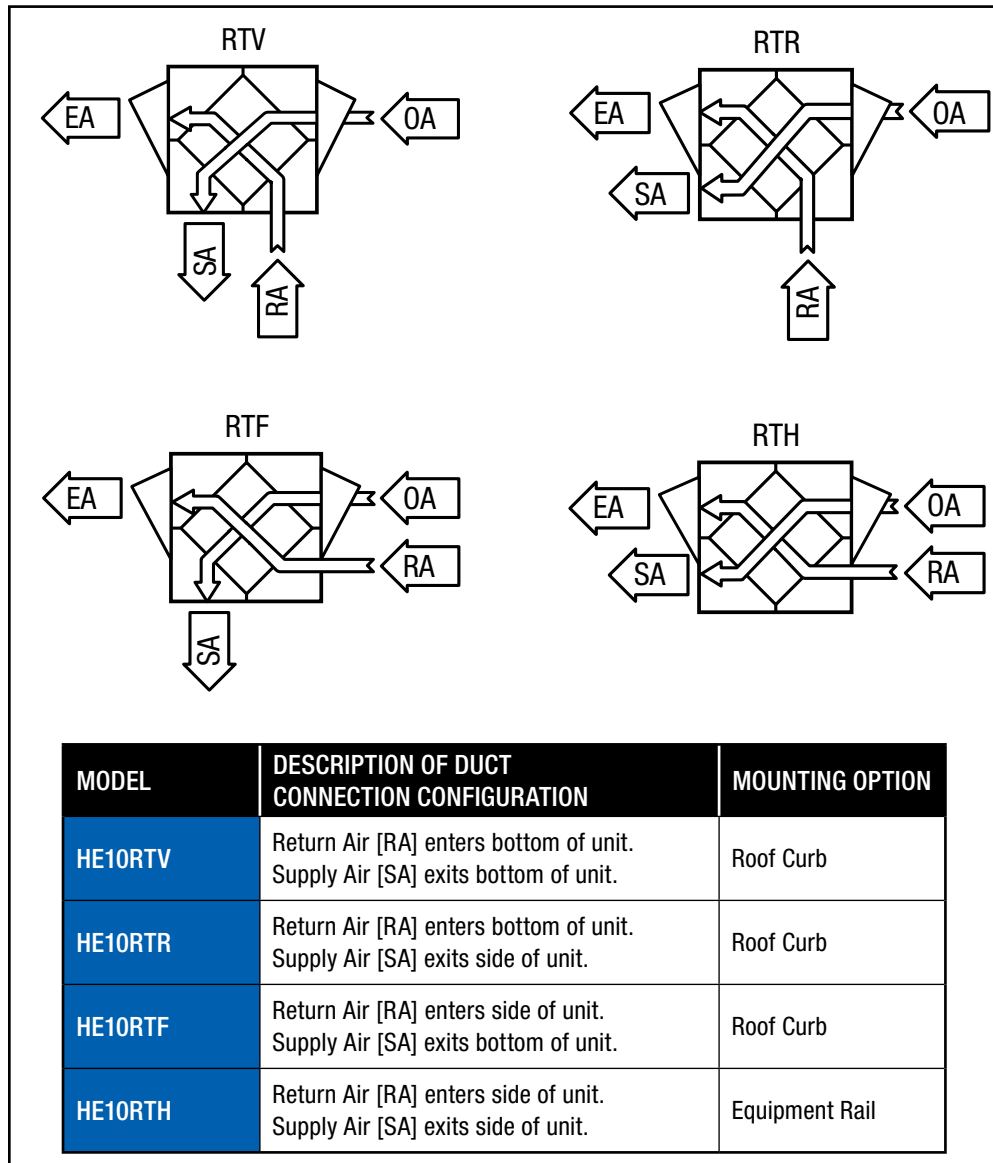

FIGURE 1.2.1 HE10RT AIRFLOW ORIENTATIONS

## 2.0 COMPONENT DESCRIPTIONS

### 2.1 CABINET

The cabinet for the HE07RT/HE10RT is made of 20 gauge galvanized steel and has 1" thick high-density, foil-backed insulation on the inside. Units are available in either single-wall or double-wall construction. Doors are hinged and are fitted with stainless steel machine screws through the faces to prevent accidental opening of the doors when the unit is in operation. Doors may be completely removed by removing the hinge pins. Duct flanges are available as an accessory for horizontal RA and SA airstream openings for connection of field-supplied ductwork.

### 2.2 ENTHALPIC CORES

All HE07RT/HE10RT ERVs use a static-plate enthalpic core. The enthalpic cores transfer both latent and sensible energies between the airstreams. Gasketing is pre-installed on the cores and must be positioned to provide a proper air seal. For information on annual maintenance of the cores, see Section 7.0 Maintenance in this manual.

### 2.3 IMPELLER/MOTOR ASSEMBLIES

There are two impeller and motor assemblies in each ERV.

### 2.4 E-BOX

Every HE07RT/HE10RT is equipped with what is known as an "E-Box." High-voltage supply wiring and low-voltage control wiring is all terminated here. If optional integrated programmable controls are installed, an additional 24VAC transformer is installed here to power both the controller and its dedicated sensors.

**⚠ CAUTION**

Low airflow can cause fouling of the enthalpic cores. The ERV must never be operated without clean filters in place and minimum airflow must be greater than 250 CFM per full-sized core.

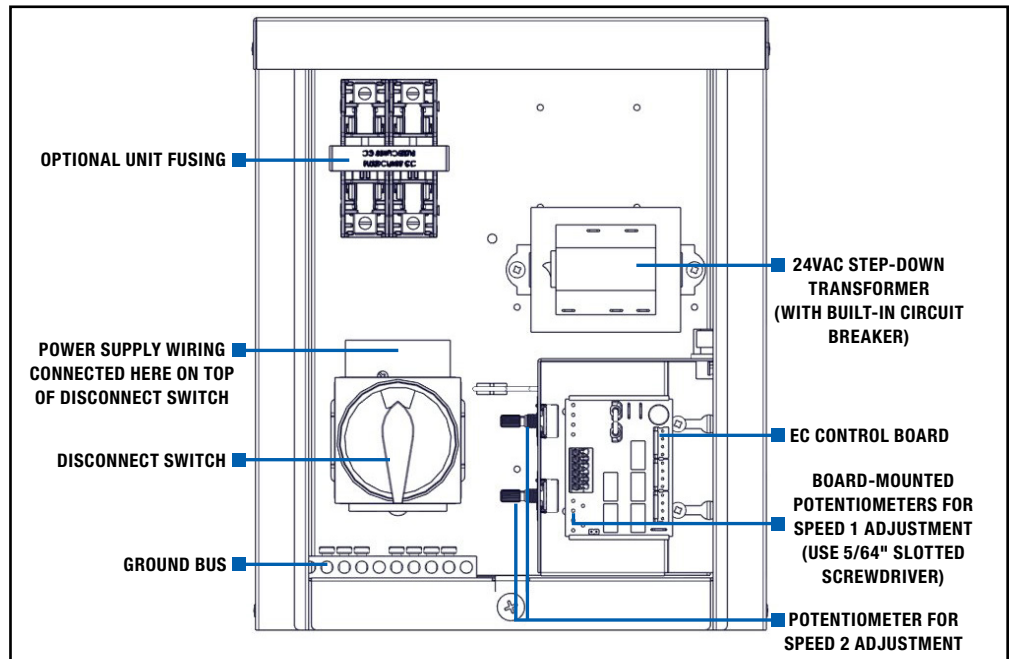

FIGURE 2.4.0 HE07RT E-BOX WITHOUT CONTROLS

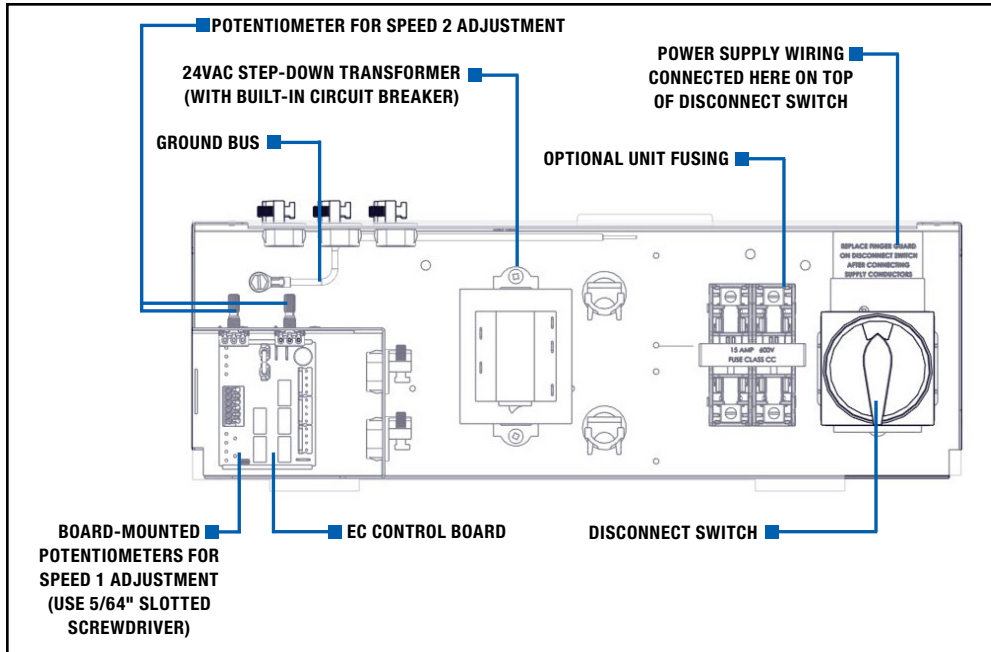

FIGURE 2.4.1 HE10RT E-BOX WITHOUT CONTROLS

## 2.5 FILTERS

All HE07RT units come equipped with two MERV 8 14" x 20" x 2" (nominal) pleated filters. All HE10RT units come equipped with two MERV 8 20" x 20" x 2" (nominal) pleated filters. MERV 13 filters can be ordered as an accessory and are shipped loose.

- HE07RT: (2) 14" x 20" x 2" (nominal) pleated filters. Actual size: 13.5" x 19.5" x 1.75"
- HE10RT: (2) 20" x 20" x 2" (nominal) pleated filters. Actual size: 19.5" x 19.5" x 1.75"
- Minimum recommended effectiveness: MERV 6.

## 2.6 FACTORY INSTALLED OPTIONS

All HE07RT/HE10RT units can be ordered with factory installed options. See Unit Configuration Code on page 6.

Options will have supplemental manuals shipped with the unit.

For Commercial Controls, see *Enhanced Controls Supplemental Manual* or *Premium Controls Supplemental Manual*.

For Filter Alarm, see *Filter Alarm Supplemental Manual*.

For Isolation Dampers, see *Isolation Dampers Supplemental Manual*.

### 3.0 SHIPPING/RECEIVING/HANDLING

HE07RT/HE10RT units are palletized at the factory and then shipped by common carrier. Upon receipt by the installer, the shipment should be inspected for shipping damage, prior to unloading. Any discovered shipping damage should be immediately reported to the RenewAire sales rep and the damage must be recorded on the Bill Of Lading, prior to signing for acceptance of the shipment. The unit can be handled with a fork lift or a crane. Prior to moving the unit, verify that all latches and securing bolts on the cabinet doors are tightly fastened.

If a crane is used for moving the HE07RT/HE10RT unit, unscrew the sheet metal plates that hold the unit to the pallet. Weatherhoods are shipped on top of the unit, supported by two 2"x4" boards. Before lifting the unit by the factory-installed lifting lugs, first install the weatherhoods in their proper locations using the provided hardware. Then remove the 2"x4" boards from the lifting lugs and discard them. Use hooks, chains, and a spreader bar to hoist the unit. The hooks must be attached to the four factory-installed lifting lugs. Unit hoisting weights and Center of Gravity are detailed in Sections 3.1 and 3.2 in this manual.

Perform a test lift to make sure the unit is being hoisted level and is secure.

Place the HE07RT/HE10RT unit on a flat surface where it will be protected from the weather and incidental damage. Do not remove protective coverings from any duct openings and keep the doors secured and tightly closed.

### 3.1 UNIT WEIGHTS AND DIMENSIONS

#### 3.1.1 HE07RT Unit Dimensions and Weight:

73 3/4" L x 34 5/8" W x 58 1/4" H  
218-373 lbs., varies by option(s)

#### 3.1.2 HE07RT Maximum Shipping Dimensions and Weight

60" L x 30" W x 82 1/4" H  
410 lbs.

#### 3.1.3 HE10RT Unit Dimensions and Weight:

81 7/8" L x 23 3/4" W x 58 1/4" H  
261-415 lbs., varies by option(s)

#### 3.1.4 HE10RT Maximum Shipping Dimensions and Weight

60" L x 30" W x 82 1/4" H  
455 lbs.

### 3.2 RIGGING AND CENTER OF GRAVITY

#### 3.2.1 HE07RT/HE10RT Hoisting Weights and COG

There are four factory-installed lifting lugs at each upper corner of the unit. Use hooks and chains at all four corners. Spreader bars are recommended in order to avoid damage to the unit.

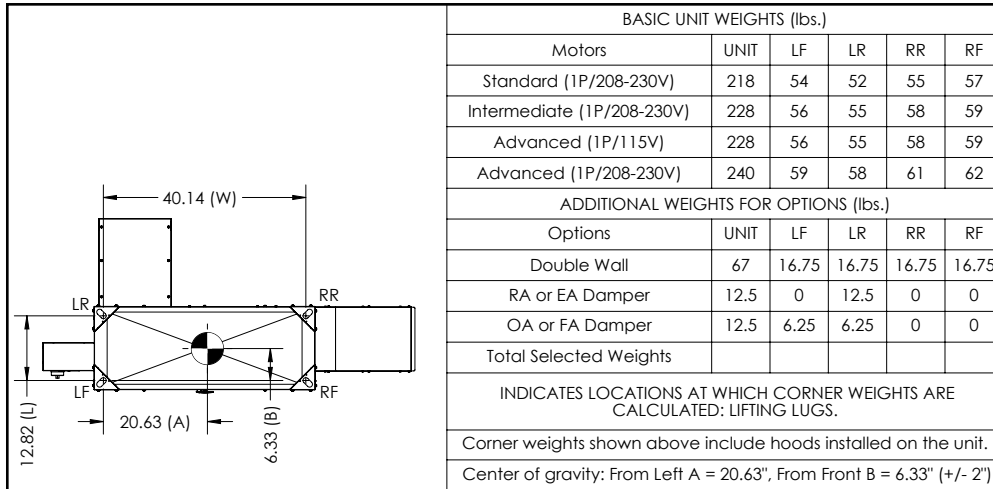

FIGURE 3.2.0 HE07RT WEIGHTS AND COG

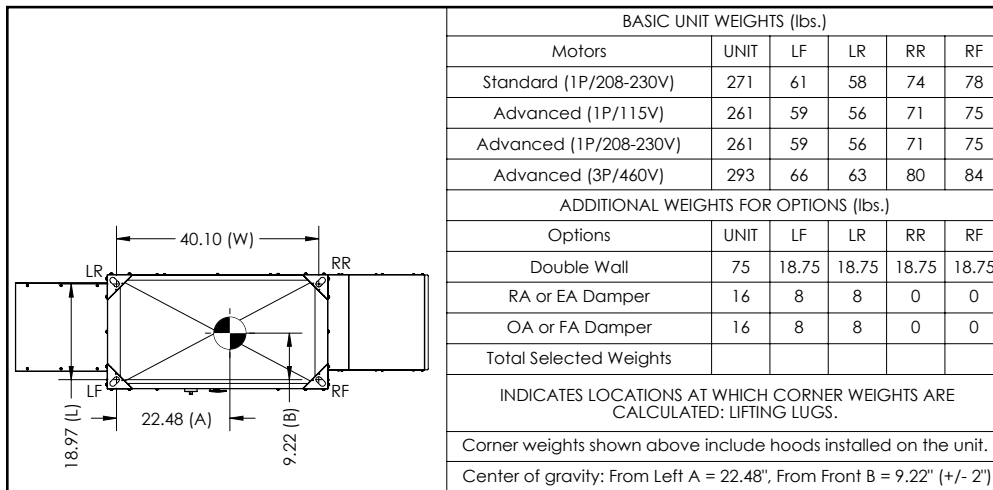

FIGURE 3.2.1 HE10RT WEIGHTS AND COG

### 3.3 RECEIVING

Upon receipt of the HE07RT/HE10RT, inspect the unit for obvious external damage. If damage is observed, take digital pictures and report the damage to your RenewAire representative. Note the damage on the carrier's Bill of Lading. Depending on expected transport and storage conditions, the unit may have only the duct openings covered, it may be stretch-wrapped or it may be crated. Do not unwrap the unit at this time. The unit will normally be moved to its final location while still wrapped and attached to its pallet.

The preferred method of hoisting the HE07RT/HE10RT from the carrier truck is by using a construction forklift or a crane.

Once the unit is unwrapped, prevent dirt and debris from entering the cabinet by covering any duct openings that do not have attached dampers. Keep the duct openings covered until it's time to connect ductwork.

### 3.4 STORAGE

Units that must be stored prior to installation should be left on their pallets and protected from weather and physical damage. Units must be placed on a level surface to prevent wracking of the pallet and the HE07RT/HE10RT. All access doors must be secured with all available hardware (door latches and securing bolts) and all openings into the cabinet must be sealed to prevent entry of dust, dirt and debris.

## 4.0 UNIT PLACEMENT

### 4.1 BEFORE YOU BEGIN

The HE07RT/HE10RT is designed for installation outdoors, typically on a rooftop. The preferred mounting method is to place the ERV on an optional manufactured curb, designed for the specific unit. **RENEWAIRE RECOMMENDS THE USE OF OPTIONAL CURB CLIPS TO PROVIDE SUBSTANTIAL RESISTANCE TO WIND DAMAGE AND ACCIDENTAL TIPPING OF THE UNIT.**

For all installations, maintain needed service clearances as shown on the dimensioned drawings located in Section 4.2 of this manual. The curb should be placed on the completed roof decking and located so that the entire perimeter of the curb rests directly on or above structural steel roof supports.

### 4.2 SERVICE CLEARANCES

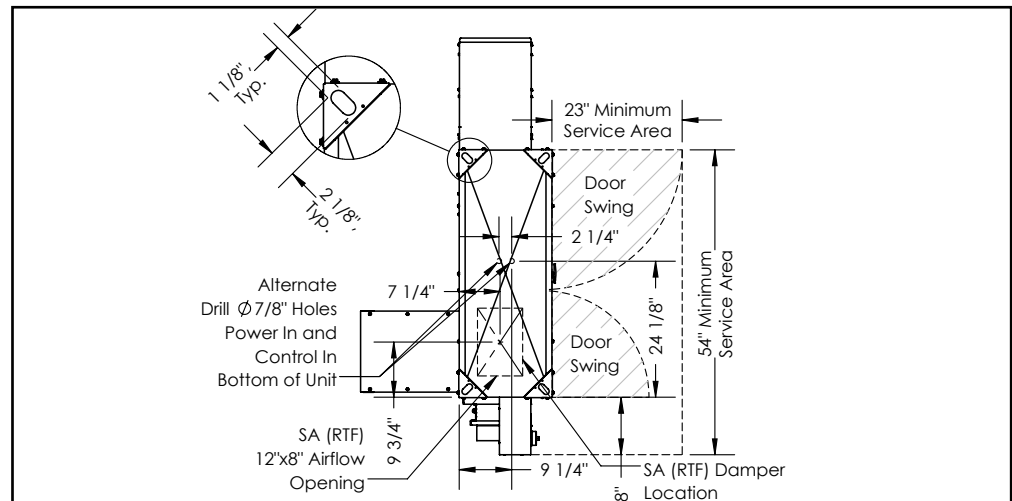

FIGURE 4.2.0 HE07RT SERVICE CLEARANCES, TOP VIEW

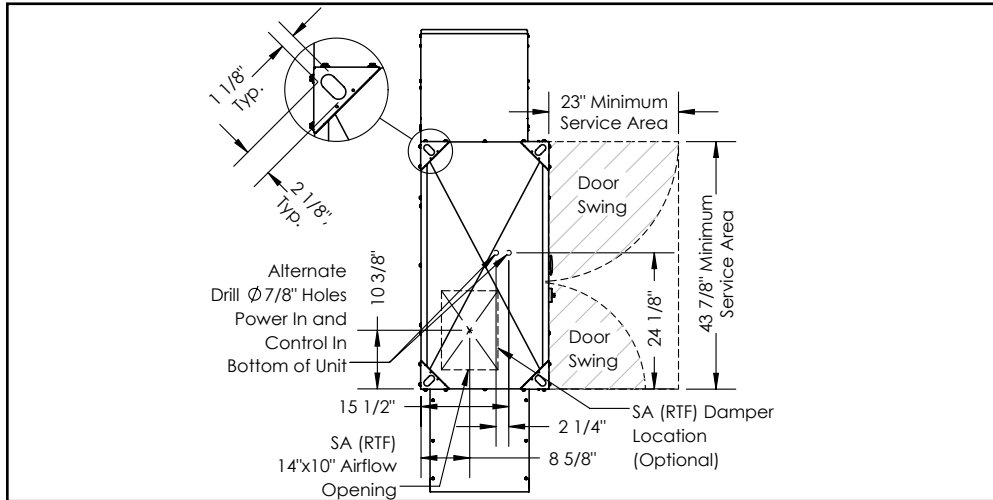

FIGURE 4.2.1 HE10RT SERVICE CLEARANCES, TOP VIEW

### ⚠ CAUTION

It is the installer's responsibility to make sure that the screws or bolts used for securing the units are properly selected for the loads and substrates involved. Secure the HE07RT/HE10RT so that it cannot fall or tip in the event of accident, structural failure or earthquake. See Rigging Information for unit weight.

RenewAire strongly recommends that you secure rooftop units properly to the building structure. Strong winds, tornadoes, and hurricanes can and do displace or remove rooftop equipment from rails or curbs. When this happens, the equipment, adjacent roof structure, and even vehicles parked near the building can be damaged, and rain typically enters the building. The equipment is put out of service and the collateral damage can be very expensive.

## 4.3 SOUND ATTENUATION

Take these simple steps to attenuate noise from the unit.

### 4.3.1 Outside the Building

The outdoor air intake hood is the primary source of noise outside the building. When practical, orient the outdoor air intake hood to point away from houses or public areas.

### 4.3.2 At the Curb

Cut the holes in the roof deck to fit closely around the duct(s) passing through the roof deck. Seal all gaps around the duct(s) at the roof deck.

### 4.3.3 Ducts

Make sure the ductwork at the unit outlets is stiff enough to resist the flexure and resulting booming associated with system start up and shut off, as well as the turbulent flow conditions at the impeller outlets.

In general, provide smooth transitions from the ERV's outlets to the duct. The ducts connecting to the outlets should be straight for a sufficient distance, with gradual transitions to the final duct size.

These guidelines are consistent with SMACNA recommended duct layout practices for efficient and quiet air movement. Follow SMACNA guidelines.

#### 4.3.4 Radiated Noise

The HE07RT/HE10RT is insulated with Expanded Polystyrene (EPS) foam. This provides significant attenuation of radiated sound from the unit itself.

The inlet ducts can be significant sources of radiated sound as well. The RA duct should be insulated for sound control. This insulation should start at the unit. At a minimum the first 10' of duct should be insulated. All parts of the SA and RA ducts located in a mechanical space with noise-generating equipment also should be insulated for sound control, both to minimize sound radiation out of the RA duct, and also to control sound radiation into both ducts.

#### 4.3.5 Connecting Horizontal Ducts to Unit

Flanged duct connections are available as an accessory for the horizontal duct connections of the HE07/10RTR, RTF, and RTH units. These allow for connection of ducts insulated on the inside or the outside, or for installation of lined duct. Please refer to dimension drawings for duct flange sizes.

## 5.0 INSTALLATION

### 5.1 CURB SPECIFICATIONS

For all rooftop curbs, the curb is to be placed in a location specified by the Architect/Engineer as being capable of supporting all known loads. Curbs are to be installed using Industry Best Practices. For installation guidelines, see the current National Roofing Contractors Association (NRCA) manuals.

For metal roofs that are supported by structural steel, the supporting structural steel must be located so that it supports the entire perimeter of the curb. Ideally, the curb will be placed directly on the structural steel and the metal roof decking is to be fitted around the curb. It is acceptable to place the metal roof decking on the structural steel and then place the curb on top of the metal roof decking. When this is done, wood fillers must be installed in the decking corrugations to provide complete support for the curb bottom flanges. In all cases, all four bottom flanges of the curb must bear directly on or over the structural steel roof supports.

For pre-stressed concrete roofs, the location of the curb must be approved by an engineer as being capable of supporting all known loads.

Curbs are shipped knocked-down and include all necessary assembly hardware, to include foam gasketing tape. To assemble the curb, assemble the four sides of the curb with the provided hardware, but leave the hardware loose. When the four curb sides are assembled, install the provided mid-rails within the curb walls and then tighten all fasteners. See Dimension Drawings on submittal for curb dimensions.

Curb clips are available as an optional accessory and can be installed as needed. Install foam gasketing (provided) on all bearing surfaces on the curb.

Optional installation of owner-provided rails (HE07RT or HE10RTH only):

RenewAire recommends that all HE07RT/HE10RT units be installed on a RenewAire-supplied curb that is manufactured to match individual units. The only units that may be installed on owner-supplied mounting rails are the HE07RTH or the HE10RTH. When owner-supplied mounting rails are used, RenewAire cannot provide installation instructions and it is the responsibility of the installer to verify compliance with all local building codes and structural integrity of the installation. Any such installation on owner-provided rails must be reviewed and approved by an engineer.



## 5.2 DUCTWORK

Basic Requirements:

Always connect an RA and an SA duct to each rooftop unit.

- With rooftop units, the RA and SA ducts cannot be interchanged.
- With RTV units, both ducts are inside the building. In other units, such as the RTR, RTF and RTH, at least one of the ducts is outside and must be weatherized.
- Any weatherized duct must be thermally insulated to prevent condensation on the inside or outside of the duct. The duct lining must be vapor-sealed, and the duct exterior must be rain tight. Duct(s) connected to the bottom of the HE07RT/HE10RT are generally installed at this time. Install (2) ducts with HE07RTV/HE10RTV, (1) duct with HE07RTR/HE10RTR or RTF.

Drop duct(s) into openings in top of roof curb.

Install appropriate gasket on top of Roof Curb and edges of ducts.

### 5.2.1 Inside Ductwork System

Follow Engineer's Ductwork Design; ductwork should be designed by an engineer to allow the unit to provide the required airflow.

### 5.2.2 Duct Insulation

If the inside ducts run through un-conditioned spaces, they must be insulated, with a sealed vapor barrier on both inside and outside of insulation.

### 5.2.3 Adjust Fan Speed to Set and Balance Airflow Rates

In most applications, the airflow rate for both the SA and the EA should be roughly equal (or "balanced") for best performance of the HE07RT/HE10RT unit. See unit specification sheet for CFM/ESP operating envelopes for available motors.

## 5.3 INSTALLATION OF HOODS

Rooftop units (RT models) have weatherhoods that are assembled at the factory and shipped on a separate pallet or on top of the unit for field installation. See instructions/figures below.

Installation of the hoods is normally performed after all rigging and hoisting is completed because of the chance of damage to the hoods by the rigging equipment.

All weatherhoods have a flange on the top rear that must be inserted behind the roof panel overhang. To install any hood, remove the factory-installed roof edge screws and keep them for re-use.

### 5.3.1 Outside Air Hood

Remove and save the screws in the roof panel overhang above the EA hood.

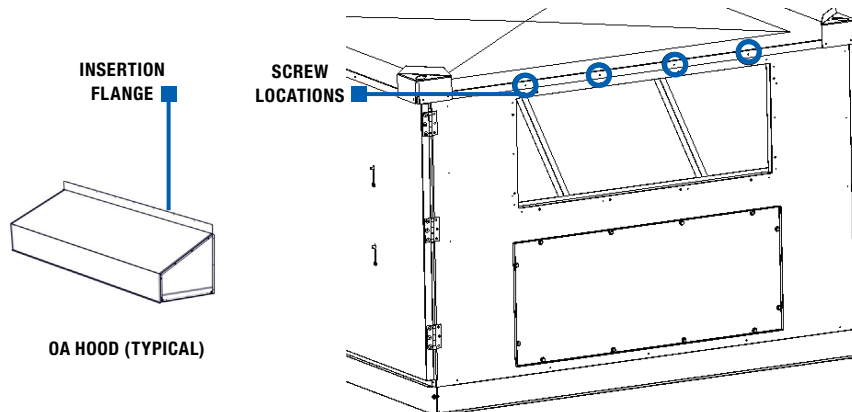

FIGURE 5.3.0 OUTSIDE AIR SCREW LOCATIONS

**NOTE:** Ducts inside a building that are connected to the outside must be insulated with a sealed vapor barrier on both the inside and the outside of the insulation.

**CAUTION**  
Tape both inner and outer vapor barriers of insulated duct to collars on duct adapters. This is critical to prevent migration of moisture into insulation. Build-up of moisture can result in failure of the duct system and/or frost in the insulation. Make sure any tears in the inner and outer vapor barriers are sealed.

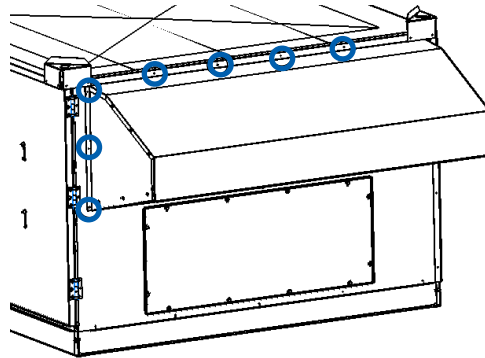

FIGURE 5.3.1 OUTSIDE AIR HOOD (TYPICAL)

Slip the top flange of the OA hood assembly under the roof panel overhang to flash the hood assembly from precipitation. You may need to pry the roof panel overhang away from the unit side pan to get the hood assembly top flange under that roof panel overhang. Align the side screw holes on the hood assembly with the holes in the unit side pan and attach the hood assembly with screws (provided). Replace the self-tapping screws that were removed from the roof panel overhang above the hood.

5.3.2 Exhaust Air Hood

Remove and save the screws in the roof panel overhang above the EA hood.

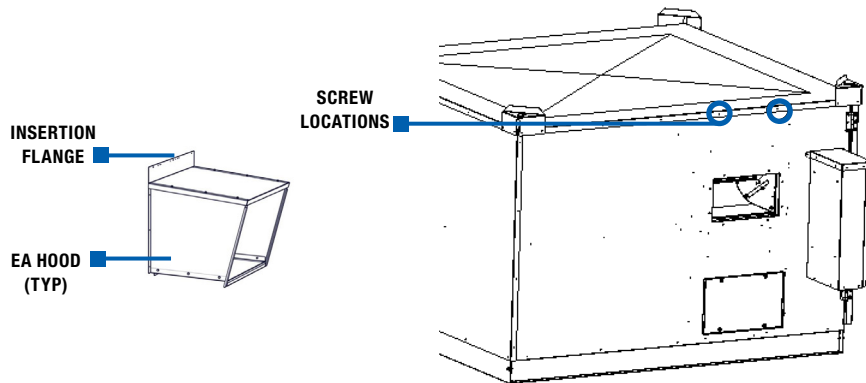

FIGURE 5.3.2 EXHAUST AIR SCREW LOCATIONS

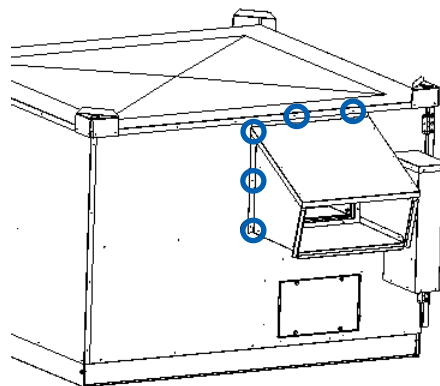

FIGURE 5.3.3 EXHAUST AIR HOOD (TYPICAL)

Slip the top flange of the EA hood assembly under the roof panel overhang to flash the hood assembly from precipitation. You may need to pry the roof panel overhang away from the unit side pan to get the hood assembly top flange under that roof panel overhang. Align the side and bottom edge screw holes on the hood assembly with the holes in the unit side pan and attach the hood assembly with screws (provided). Replace the self-tapping screws that were removed from the roof panel overhang above the hood.

### 5.4 ELECTRICAL REQUIREMENTS

Electrical Options and Ratings are identified on the Unit Label (located near electrical box). Find the complete Unit Model Number in the lower left corner of the Unit Label.

#### 5.4.1 Factory-Recommended Electric Service Entry

For the HE07RT, knockouts are provided in the bottom of the E-box for entry of high-voltage power supply and low-voltage control wiring. The HE10RT has an internal E-box in the lower left corner of the unit. A label on the left side of the HE10RT indicates where to drill for high-voltage power and low-voltage control entry. Alternatively, each unit allows for wiring to enter through the curb and unit floor. A label inside the RA compartment of unit indicates where to drill for high-voltage power and low-voltage control entry. Install the wiring in accordance with local codes and provide strain relief at the E-box opening.

High-voltage supply wiring is to be connected on the top side of the disconnect switch. See image below.

**NOTE:** Your unit is equipped with EC Motors (ECM). Use conduit, strain reliefs, etc. as required by code to secure the field wiring.

**CAUTION**  
Before bringing power to the unit check unit nameplate to confirm it matches the voltage and phase of the power you are supplying. Remember that your field connections need to be accessible for inspection.

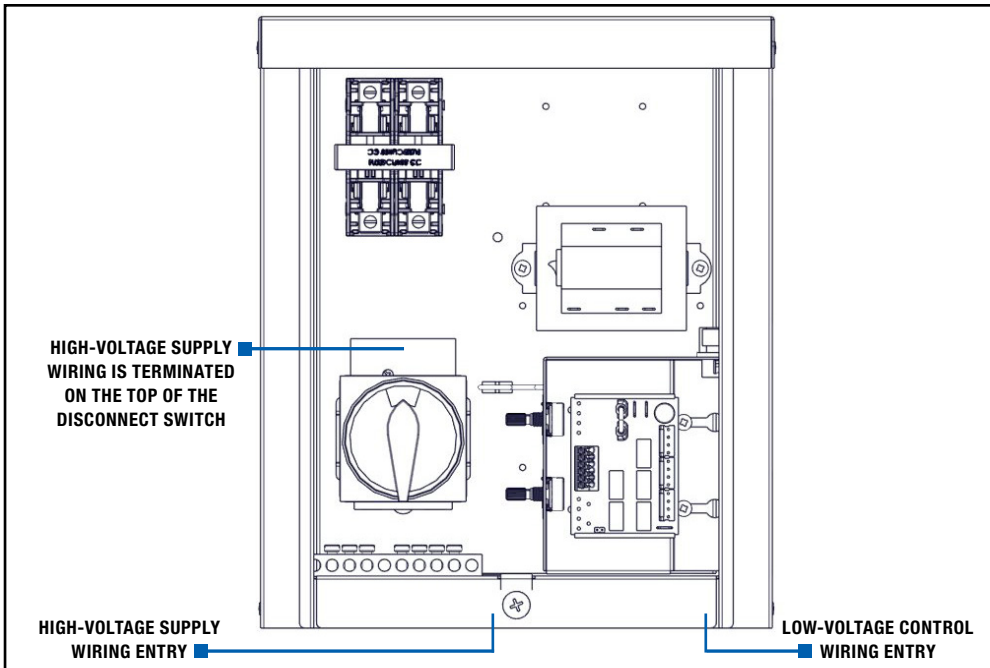

FIGURE 5.4.0 HE07RT E-BOX WIRING ENTRY POINTS

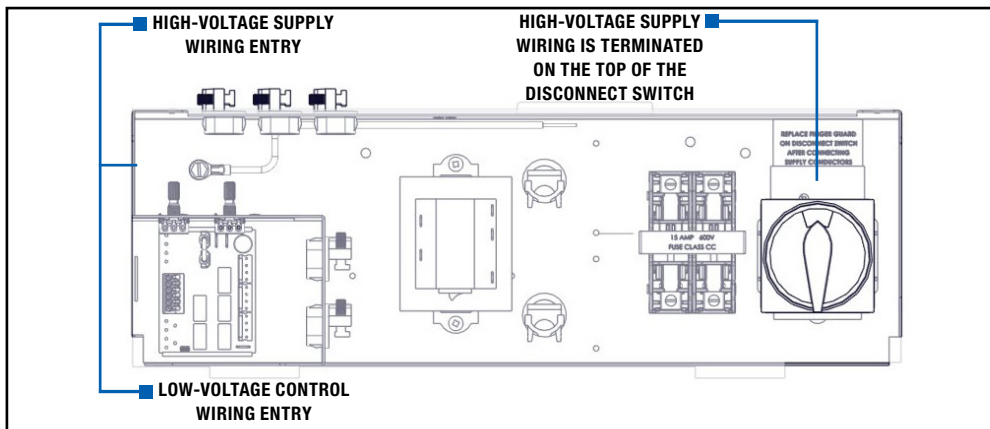

FIGURE 5.4.1 HE10RT E-BOX WIRING ENTRY POINTS

5.4.2 Low Voltage Control System

This ERV is provided with a Class II 24VAC power supply system that operates the unit’s EC control board. The ERV’s 24VAC Power Supply can also be used to power the externally-installed controls system: up to 8VA of power is available.

The unit’s power supply system includes isolation relay(s) so you can use external controls whose contact ratings are as low as 50 mA (1.2 VA). Also, it is possible to operate the isolation relays with 24VAC power from an external source (with proper wiring connections).

A built-in circuit-breaker prevents damage to the transformer and other low-voltage components in the event of a short-circuit or overload. In extreme cases, the transformer itself is designed to fail safely.

Specifications:

- Nominal Output Voltage under load: 24VAC
- Typical Output Voltage at no load: 29–31 V
- Minimum contact rating for connected control device: 50 mA (1.2 VA)
- Circuit Breaker Trip Point: 3 A

**NOTICE**

If primary-side voltage is 230VAC, move black primary-side lead from transformer’s “208V” terminal to the transformer’s terminal marked “240V” (“230V” in some units). Do not move the black primary-side lead that is connected to the transformer’s “COM” terminal.

**⚠ CAUTION**

1. Connect only to components intended for use with 24VAC power.
2. Do not undersize the low-voltage wires connected to this device. Observe the wire length and gauge limits indicated in this manual.
3. Do not overload this unit’s 24VAC power supply system. Confirm that the power requirements of devices you connect to this power supply system do not exceed 8VA in total.
4. If an external source of 24VAC power is used to control the unit, consult the wiring schematics and connect the external power only to the specified terminals in order to avoid damaging the unit or external controls. Connect only CLASS II power to the control terminals of this unit.

**⚠ CAUTION**

Be careful if the external control system provides 24VAC power at its control output: make sure blue and red leads are separately capped and not connected to any other wires.

5.4.3 How to Reset the 24VAC Circuit Breaker

If the transformer is subjected to an excessive load or a short circuit, the circuit breaker will trip to prevent the failure of the transformer. When it trips the circuit breaker’s button pops up. Shut off the primary-side power to the unit, and remove the excessive load or the short. The circuit breaker can be reset about fifteen seconds after it trips by pressing in the button.

5.4.4 Limits of Power Output

If limits on wire gauge and length are observed, you may connect control devices that draw up to 8VA to the blue and red wires. More than one device can be connected as long as total steady-state load does not exceed 8VA.

Wire Gauge	#22	#20	#18	#16	#14	#12
Circuit Length	100'	150'	250'	400'	700'	1000'

“Circuit Length” is distance from ERV to Control Device.  
 Observe these limits to wire length and gauge in order to ensure reliable operation of the control system.



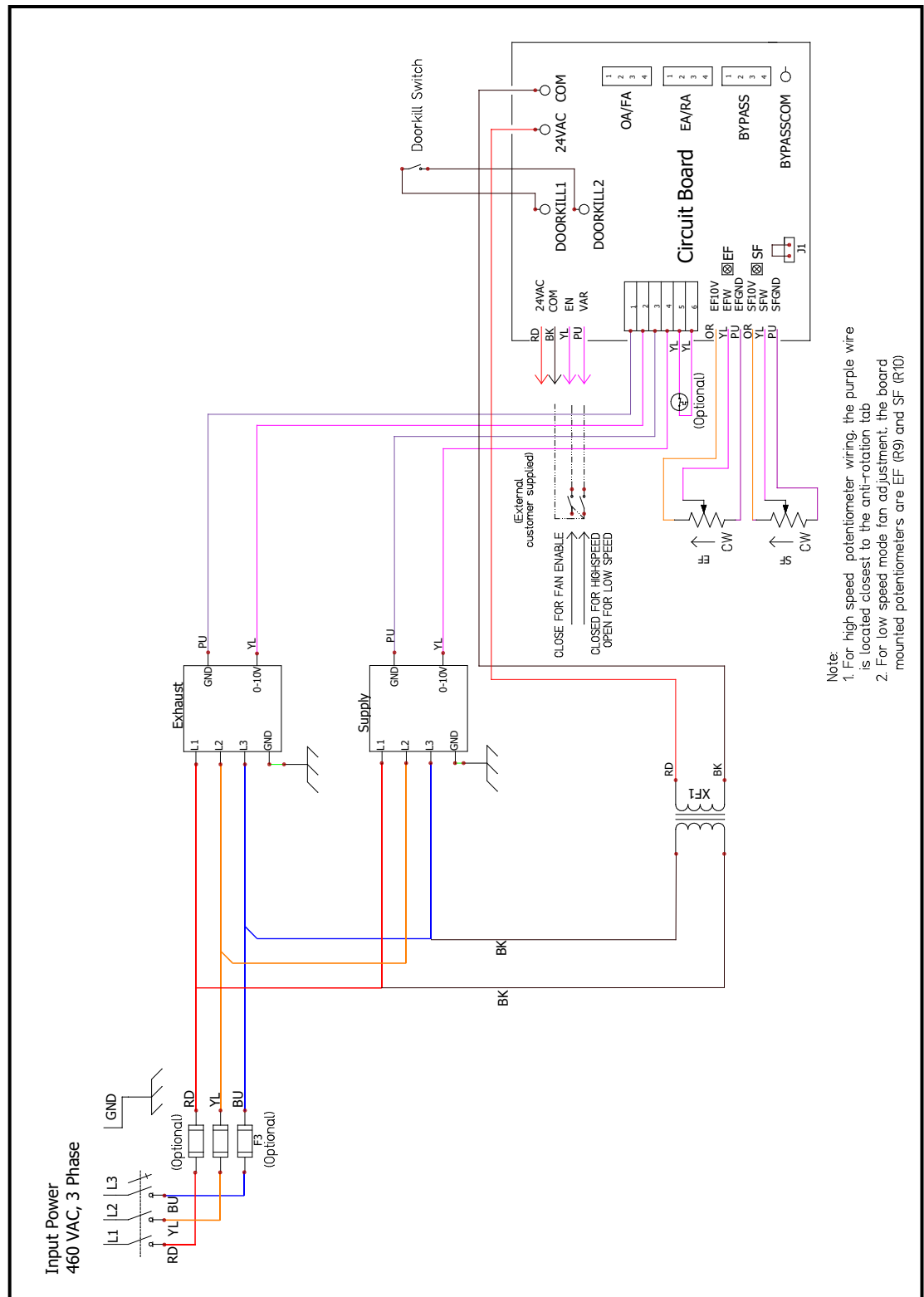

FIGURE 5.5.1 THREE PHASE UNIT, STANDARD (HE10RT ONLY)

## 5.6 EXTERNAL CONTROL CONNECTIONS

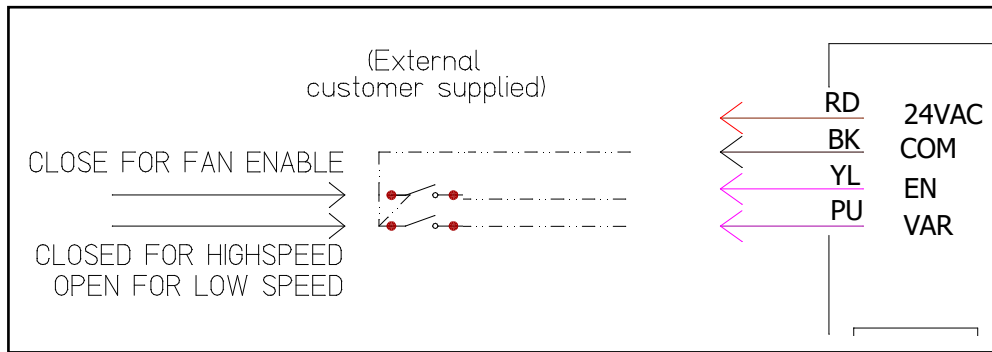

FIGURE 5.6.0 FIELD CIRCUIT DETAIL

### 5.6.1 Fan Enable Field Circuit

The standard control board on the HE07RT/HE10RT is designed for fan enable via a single switch or field circuit.

- To enable fan operation for both fans, close contact between the yellow EN wire and the black COM wire.

### 5.6.2 Fan Speed Selection Field Circuit

The standard control board on the HE07RT/HE10RT is designed for two-speed operation, with each speed enabled via a single switch or field circuit.

- To enable SPEED 1 for both fans, open contact between the purple VAR wire and the black COM wire.
- To enable SPEED 2 for both fans, close contact between the purple VAR wire and the black COM wire.

### 5.6.3 Fan Speed Adjustment

The standard control board on the HE07RT/HE10RT allows for field adjustment of SPEED 1 and SPEED 2 via trimming potentiometers.

- SPEED 1 is set using the two board-mounted trimming potentiometers labeled EF for the exhaust fan and SF for the supply fan. Use a 5/64" slotted screwdriver to adjust SPEED 1 for each fan. Turn the potentiometers gently to avoid damaging the control board. Do not force them to turn past the end stop.
- SPEED 2 is set using the two panel-mounted trimming potentiometers labeled EA/RA motor for the exhaust fan and OA/SA Motor for the supply fan. Turn the potentiometers by hand or use a flat head screwdriver to adjust SPEED 2 for each fan.

### 5.6.4 Analog Signal for Controlling SPEED 2

To utilize an external 0–10VDC analog signal for SPEED 2:

1. Remove each panel mounted potentiometer by cutting the wires at the potentiometer.
2. Connect the remote analog signal to the yellow wire from the potentiometer.
3. Connect the remote signal ground to the purple wire from the potentiometer.
4. Cap the orange wire from the potentiometer with a wire nut.

## 5.7 QUICK-START FOR TESTING CORRECT 3PH WIRING

All units that run on 3 phase power should be test-run immediately after high voltage wiring connections are made. This will verify that the three phases are properly connected, that the dampers will open and close properly and the fans are working properly.

For purposes of testing correct phase connections, the internal 24VAC power supply will be used to power-up the fans and all external control devices will be disabled, when applicable.

 NOTE: The simplified schematics below show only the relevant portions of the low-voltage control circuit in the ERV unit and representational external control approaches. See the complete unit schematics above.

**⚠ CAUTION**  
Make sure the control provides no voltage or current at its output terminals.

 NOTE: Any changes to unit low-voltage wiring should be made with the disconnect switch in the "OFF" position.

## 6.0 OPERATION

### 6.1 PRINCIPLE OF OPERATION

The HE07RT/HE10RT has one basic purpose: to exhaust air from a structure and bring in SA from outside, while transferring heating or cooling energy from the EA to the SA.

The HE07RT/HE10RT is a very simple device, and will accomplish this purpose as long as the impeller is able to move air through the enthalpic core.

### 6.2 PRE-START UP

#### 6.2.1 Verify Voltages

Using a voltmeter, test the input voltages as supplied to the disconnect switch. Refer to Digit 13 of the unit Configuration Code to find the rated voltage. The supplied voltage must be within +/- 10% of the rated voltage.

#### 6.2.2 Verify Transformer Wiring

Units with 230VAC power source are shipped with the transformer wired for 208VAC. If the unit is receiving 230VAC, make sure the black primary-side wire on the transformer's 208V terminal has been moved to the 230V terminal.

#### 6.2.3 Inspect Filters

Clean filters must be installed prior to fan start up.

#### 6.2.4 Inspect Foam Gasketing

Inspect the gasketing to make sure there are no gaps allowing air movement around the cores or filters.

#### 6.2.5 Inspect Fans

Prior to start up, the fans should be rotated by hand to make sure that the impeller is not rubbing anywhere and that they turn freely.

#### 6.2.6 Inspect and Clean the Cabinet Interior

During the construction and installation phases of a project, dust, dirt and debris will often accumulate inside a unit. Thoroughly clean the inside of the unit by vacuuming and/or wiping metal surfaces with a damp rag.

#### 6.2.7 Inspect Ductwork Connections

Ducts attached to the ERV must be firmly attached, sealed and supported in accordance with installation instructions and SMACNA guidelines.

### 6.3 UNIT START UP

#### 6.3.1 Starting Up ECM Units

Units equipped with standard control do not require any external controlling signals and only require turning on the disconnect switch, located on the E-Box or cabinet access door. When the disconnect switch is turned "ON" any dampers will first move into their correct operating positions and then a speed signal is supplied to the motorized impellers, causing the fans to run.

Some units equipped with standard control are wired to receive an actuating signal from an external source. If there is an external actuation signal source, verify the type of signal and that it is wired according to the low-voltage wiring diagrams found in Section 5.6 of this manual. Turn "ON" the disconnect switch and then turn "ON" the actuating device. After any dampers have moved into their correct positions, a speed signal is supplied to the motorized impellers, causing the fans to run.



**NOTE:** The door interlock switch will prevent the fans from turning on if the access door on that side is open.



**IMPORTANT**

It is important to balance the airflows after the unit is operational and all ductwork has been installed. Balancing the airflows is typically required by state and/or local codes, and is often specified by the HVAC design engineer.

Optimum efficiency of the enthalpic cores is achieved when the airstreams are properly balanced.

**6.4 BALANCING AIRFLOW**

Airflow should be occurring in both airstreams. Sometimes the easiest place to confirm that air is moving is at the weatherhoods.

If exact airflow is critical, it may be desirable to permanently install flow measuring stations and manometers in the ductwork connected to the unit. These also can be used to determine when filters should be cleaned or changed.

Equipment Required:

- A magnehelic gauge or other device capable of measuring 0–1.5 in. water of differential pressure.
- 2 pieces of natural rubber latex tubing, 1/8" ID, 1/16" Wall works the best.

Procedure:

The individual differential static pressures (DSP) can be measured using the installed pressure ports located in the front of the units core access doors.

- To read SCFM of SA install the “high” pressure side (+) of your measuring device to the OA port and the “low” pressure side (-) to the SA port.
- To read SCFM of RA install the “high” pressure side (+) of your measuring device to the RA port and the “low” pressure side (-) to the EA port.
- Use the reading displayed on your measurement device to cross reference the CFM output using the conversion chart.

 **NOTE:** ERV airflows are to be balanced after all ductwork is installed. Balancing of airflows is typically required by local or state building codes or by the HVAC design engineer.

 **NOTE:** The tubing should extend in the pressure port approx. 1".

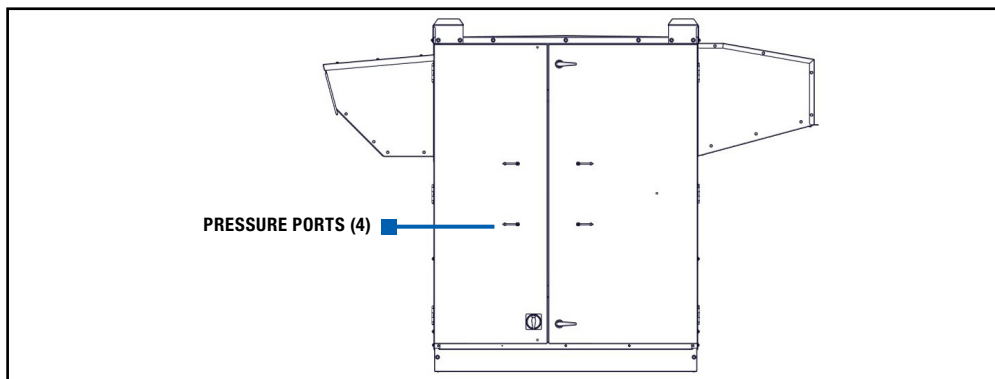



FIGURE 6.4.0 PRESSURE PORT LOCATIONS

 **NOTE:** These ports have been carefully located on the unit as to give you the most accurate airflow measurement. Do not relocate pressure ports.

**DIFFERENTIAL STATIC ACROSS CORE DSP VS. CFM**

	DP (H <sub>2</sub> O)	DSP	0.20	0.30	0.40	0.50	0.60	0.70	0.80	0.90	1.00	1.10
<b>HE07RT</b>	Supply air (SA)	CFM	150	230	310	380	460	540	610	690	760	840
	Return Air (RA)	CFM	150	230	310	380	460	540	610	690	760	840
<b>HE10RT</b>	Supply air (SA)	CFM	230	350	460	580	690	810	920	1040	1150	1270
	Return Air (RA)	CFM	230	350	460	580	690	810	920	1040	1150	1270

**⚠ CAUTION**  
The proper operating airflow range for these models are:  
HE07RT: 166–694 CFM  
HE10RT: 250–1100 CFM.

6.4.1 Filter Pressure Drop

 NOTE: Clean filter pressure drop is included in unit airflow performance tables.

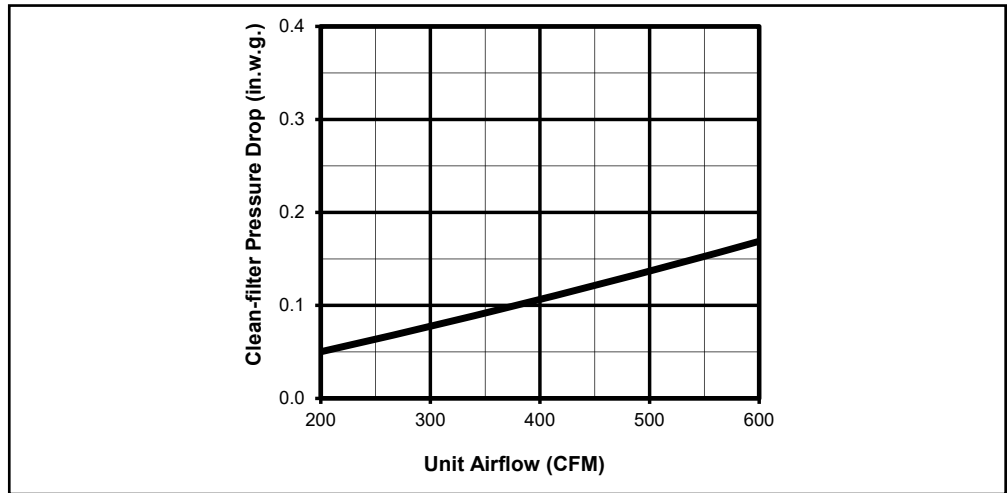

FIGURE 6.4.1 INITIAL PRESSURE DROP OF MERV 8 FILTERS, SUPPLIED WITH HE07

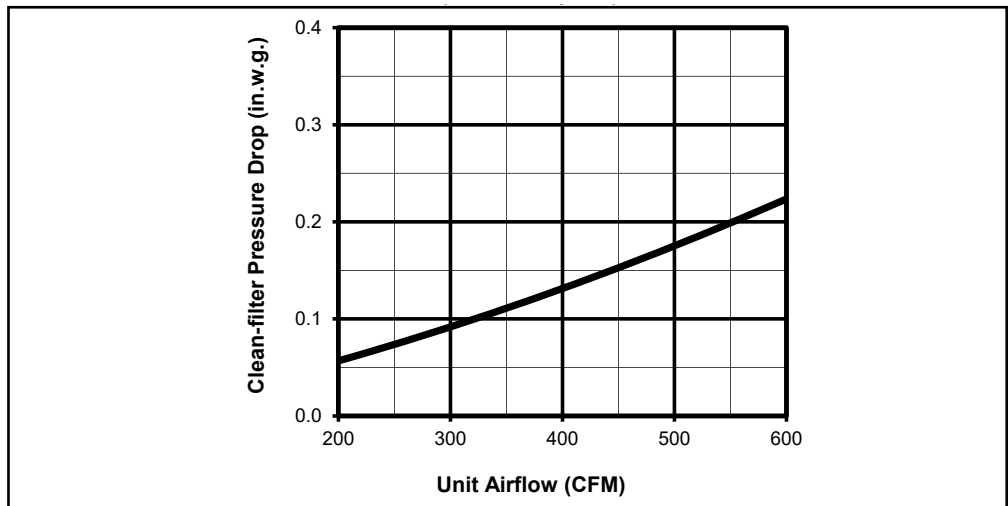

FIGURE 6.4.2 INITIAL PRESSURE DROP OF MERV 13 FILTERS, AVAILABLE AS AN HE07 ACCESSORY

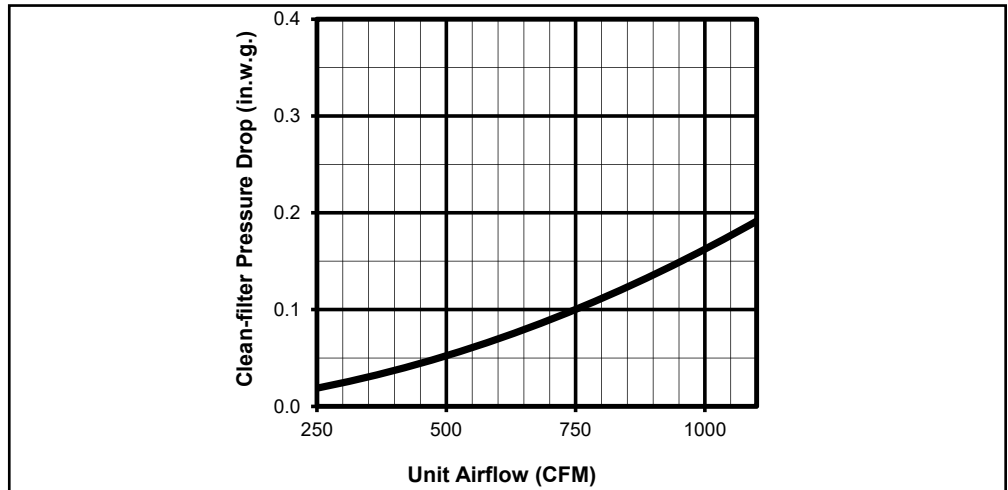

FIGURE 6.4.3 INITIAL PRESSURE DROP OF MERV 8 FILTERS, SUPPLIED WITH HE10

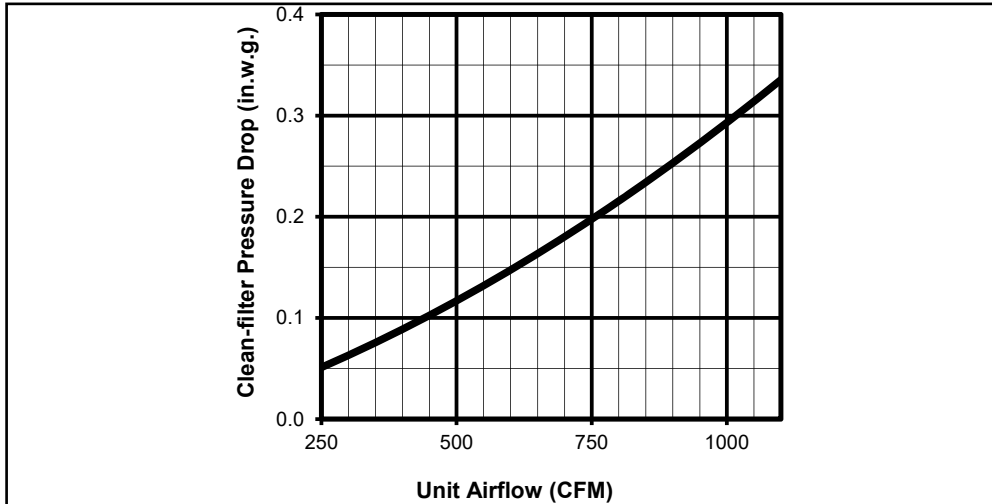



FIGURE 6.4.4 INITIAL PRESSURE DROP OF MERV 13 FILTERS, AVAILABLE AS AN HE10 ACCESSORY

 NOTE: Clean filter pressure drop is included in unit airflow performance tables.

## 6.5 NORMAL OPERATION

A wide variety of control schemes may be selected by the engineer, installer, or owner to meet the ventilation needs of the facility. These may include timer clocks, occupancy sensors, dehumidistats (for cool-weather operation), carbon dioxide sensors, and others. DDC systems may also control the unit. Most control schemes will operate the unit only when needed.

Continuous operation is acceptable in virtually all conditions. Unit will not be damaged by continuous operation as long as airflow occurs. Impeller motors may overheat if filters become completely blocked due to lack of maintenance. Motors are thermally protected. With continuous operation, some external frosting may occur in very cold weather (see Section 6.6).

## 6.6 OPERATION IN EXTREME COLD WEATHER

HE07RT/HE10RT units are capable of operating without internal frosting at temperatures down to -10°F, with indoor humidity below 40%. The units can operate under more severe conditions occasionally with little or no impact on their performance. At lower humidities, they can operate at still lower outside temperatures without freezing the enthalpic cores.

Some condensation or even frost may form on the outside of the unit or drip off the cabinet during very cold conditions, especially if the unit runs continuously. Exterior condensation during extreme cold conditions can be reduced or prevented by periodically cycling the unit “OFF” for several minutes to allow the cabinet to warm up.

## 7.0 MAINTENANCE

RenewAire ERVs are built to operate with minimal maintenance. After unit commissioning, the primary areas of attention are the air filters and annual vacuuming of the enthalpic cores.

### 7.1 MAINTENANCE 24 HRS. AFTER START UP

24 hours after unit start up:

- In new installations, check the air filters since they will often collect dust, dirt, and debris at time of start up.

### 7.2 MAINTENANCE 30 DAYS AFTER START UP

After 30 days of operation:

- Tighten all electrical connections.
- Check the air filters as part of the normal monthly maintenance.

**⚠ WARNING**  
 Danger of injury if unit starts unexpectedly. Switch power off at service disconnect. Lock-out/tag-out the disconnect.

**⚠ WARNING**

Danger of Electrical Shock when servicing an installed unit.

ALWAYS DISCONNECT POWER SOURCE BEFORE SERVICING! More than one disconnect switch may be required.

Proper Wiring Size Selection and Wiring Installation are the Responsibility of the Electrical Contractor.

**7.3 MAINTENANCE SCHEDULE**

Experience on the part of the service person is the most important issue in establishing a maintenance schedule. There will be times of the year when frequent inspection of the filters will be required, such as spring and summer when there may be pollen, dust, dirt or debris from budding trees and bushes that can clog the filters. Also see Section 7.7 Maintenance Records in this manual.

**7.4 FILTERS**

Inspection and replacement of air filters is the most frequent maintenance issue. For units that do not have filter air pressure differential sensors, filters must be visually inspected monthly, at a minimum. If a filter looks discolored or dirty, REPLACE IT! When installing new filters, DO NOT USE filter sprays. Residue from the filter spray could migrate to the enthalpic core media and damage the cores.

For units that have filter air pressure differential sensors, a dirty filter alarm will occur on the connected alarm or control device.

Filter cleanliness and replacement is the most important and frequent maintenance issue. Dirty filters will cause an immediate reduction in operating efficiency of the ERV. Normally, filters should be inspected and changed when they are dirty. Paper filters are not to be cleaned, they are to be replaced.

In general, if a filter looks dirty, replace it. The best indication of dirty filters is to check the pressure drop across the filter banks with an optional filter monitor. If it is not possible to check the pressure drop, the rule of thumb would be to change the filters every two months.

**7.5 IMPELLER MOTOR**

The motor needs no lubrication. If necessary vacuum clean the impeller at the same time you clean the face of the energy exchange element (annually).

**7.6 ENTHALPIC CORE**

**⚠ CAUTION**

**RISK OF DAMAGE TO ENTHALPIC CORES**

Whenever working within the ERV cabinet, protect the enthalpic cores from accidental damage. The core media is subject to damage from dropped tools or other foreign objects.

**7.6.1 Enthalpic Core Maintenance**

The enthalpic core media is a fibrous material that must be kept clean at all times. As a minimum, cores should be cleaned once per year.

- DO NOT WASH OR ALLOW THE ENTHALPIC CORES TO GET WET.
- DO NOT EXPOSE THE ENTHALPIC CORES TO HIGH HEAT OR FLAMES.
- DO NOT DIRECT COMPRESSED AIR AT THE CORE MEDIA.
- DO NOT REMOVE THE ENTHALPIC CORES FROM THE ERV UNLESS NECESSARY.
- USE CAUTION WHEN WORKING AROUND THE ENTHALPIC CORES. DO NOT DROP TOOLS OR OTHER OBJECTS ON THE CORES, DO NOT BUMP OR TWIST THE CORES.

To access enthalpic cores for cleaning, remove the air filters.

To clean enthalpic cores, all exposed surfaces must be vacuumed with an attachment having long, soft bristles. The greatest buildup of dirt and dust will normally be on the leading 1–2 inches of the inlet side (closest to the air filters).



### 7.8 SERVICE PARTS

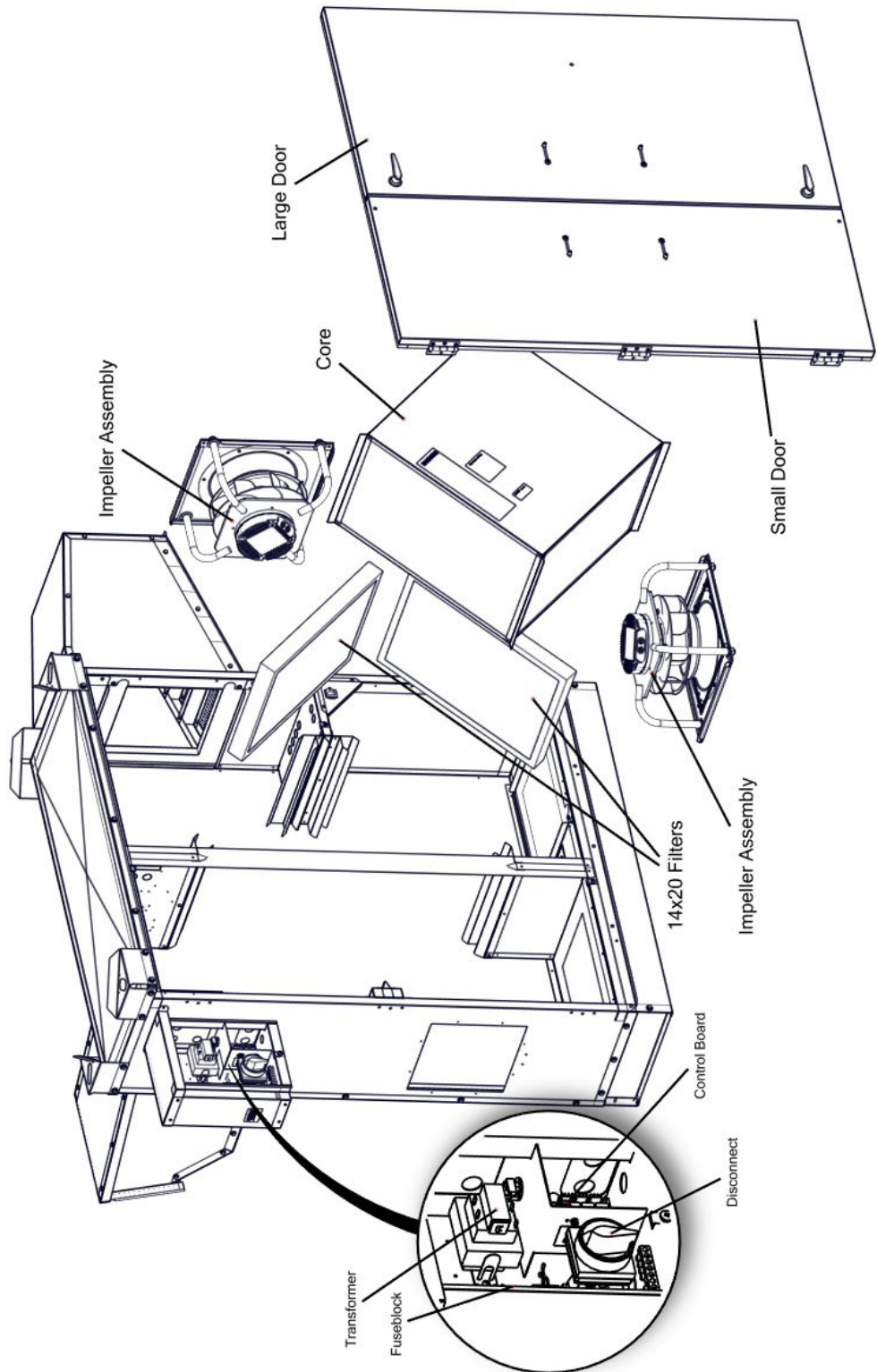

FIGURE 7.8.0 HE07RT SERVICE PARTS

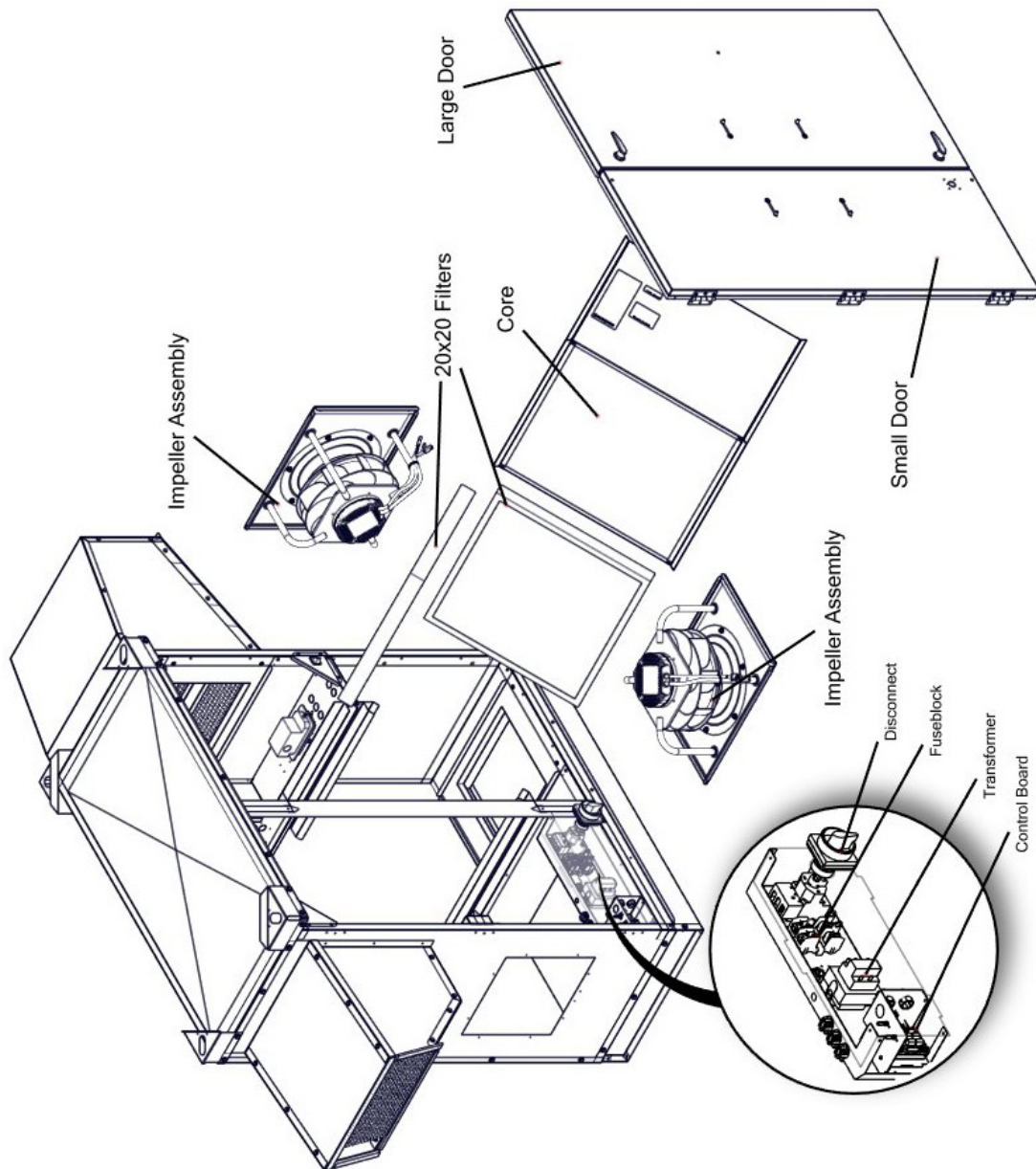

FIGURE 7.8.1 HE10RT SERVICE PARTS

## 8.0 TROUBLESHOOTING

If problems occur with a RenewAire ERV, the primary resources for troubleshooting are the unit as-built wiring schematics and the Sequence Of Operation (SOO) for each control scheme.

## 9.0 FACTORY ASSISTANCE

In the unlikely event that you need assistance from the factory for a specific issue, make sure that you have the information called for in the Unit Information page in the front of this manual. The person you speak with at the factory will need that information to properly identify the unit.

**To contact RenewAire Customer Service:**

**Call 800-627-4499**

**Email: [RenewAireSupport@RenewAire.com](mailto:RenewAireSupport@RenewAire.com)**





## About RenewAire

For over 40 years, **RenewAire** has been a pioneer in enhancing indoor air quality (IAQ) in commercial and residential buildings of every size. This is achieved while maximizing sustainability through our fifth-generation, static-plate, enthalpic-core **Energy Recovery Ventilators (ERVs)** that optimize energy efficiency, lower capital costs via load reduction and decrease operational expenses by minimizing equipment needs, resulting in significant energy savings. Our ERVs are competitively priced, simple to install, easy to use and maintain and have a quick payback. They also enjoy the industry's best warranty with the lowest claims due to long-term reliability derived from innovative design practices, expert workmanship and **Quick Response Manufacturing (QRM)**.

As the pioneer of static-plate core technology in North America, RenewAire is the largest ERV producer in the USA. We're **committed to sustainable manufacturing** and lessening our environmental footprint, and to that end our Waunakee, WI plant is 100% powered by wind turbines. The facility is also one of the few buildings worldwide to be LEED® Gold and Green Globes certified, as well as having achieved ENERGY STAR Building status. In 2010, RenewAire joined the Soler & Palau (S&P) Ventilation Group in order to provide direct access to the latest in energy-efficient air-moving technologies. For more information, visit: [renewaire.com](http://renewaire.com)

201 Raemisch Road | Waunakee, WI | 53597 | 800.627.4499 | [RenewAire.com](http://RenewAire.com)