

HE SERIES ERV

Installation, Operation and Maintenance Manual

HE1.5XINH

HE1.5XINV

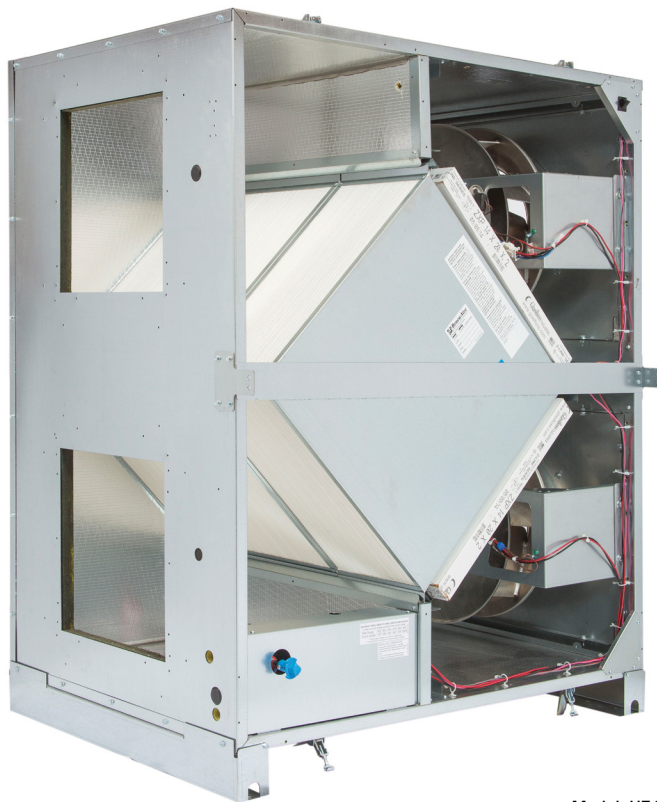

Model: HE1.5XINH shown



▲ WARNING

Standard HE1.5XIN with single phase original equipment motors are NOT suitable for use with solid state speed control.

Three phase motors are NOT suitable for use with solid state speed control.

Single phase ECM motors are NOT suitable for use with solid state speed control. They already have speed control built into the motor electronics.

▲ AVERTISSEMENT

Le HE1.5XIN avec moteurs d'équipement d'origine mono-phasés ne convient pas pour une utilisation avec regulateur de vitesse électronique.

Moteurs de trois phase ne convient pas pour utilisation avec regulateur de vitesse électronique.

Moteurs d'une phase de l'ECM ne conviennent pas pour une utilisation avec regulateur de vitesse électronique. Ils ont déjà le contrôle de vitesse intégré dans le moteur électronique.

▲ WARNING**ARC FLASH AND ELECTRIC SHOCK HAZARD**

Arc flash and electric shock hazard. Disconnect all electric power supplies, verify with a voltmeter that electric power is off and wear protective equipment per NFPA 70E before working within electric control enclosure. Failure to comply can cause serious injury or death.

Customer must provide earth ground to unit, per NEC, CEC and local codes, as applicable.

Before proceeding with installation, read all instructions, verifying that all the parts are included and check the nameplate to be sure the voltage matches available utility power.

The line side of the disconnect switch contains live high-voltage.

The only way to ensure that there is NO voltage inside the unit is to install and open a remote disconnect switch and verify that power is off with a volt meter. Refer to unit electrical schematic. Follow all local codes.

▲ WARNING**RISK OF INJURY OR DAMAGE**

Motor may have a manual reset thermal protector. Disconnect power before servicing or resetting motor thermal protector. Use caution, motor may be hot. Allow the motor to cool before resetting the thermal protector.

If the motor thermal protector tripped, correct the issue that caused the motor to overheat (e.g. over motor rated amperage or locked rotor).

If the motor has a manual reset thermal protector, the red thermal protector reset button is located on the motor body, on or near the lead end of the motor. If the button does not reset, the motor may still be too hot. Allow the motor to fully cool to reset the thermal protector, you should feel or hear a click when the thermal protector resets while pushing the reset button.

▲ CAUTION**RISK OF ELECTRIC SHOCK OR EQUIPMENT DAMAGE**

Whenever electrical wiring is connected, disconnected or changed, the power supply to the ERV and its controls must be disconnected. Lock and tag the disconnect switch or circuit breaker to prevent accidental reconnection of electric power.

▲ CAUTION**RISK OF CONTACT WITH HIGH SPEED MOVING PARTS**

Disconnect all local and remote power supplies, verify with a voltmeter that electric power is off and all fan blades have stopped rotating before working on the unit.

Do not operate this unit with any cabinet panels removed.

READ AND SAVE THIS MANUAL/LIRE ET CONSERVER CE MANUEL

NOTICE

This manual contains space for maintaining written records of unit maintenance and/or repairs. See Section 7.7 Maintenance Records. At the time the ERV is commissioned, a maintenance schedule should be developed by the user to incorporate monthly and seasonal maintenance and include start up maintenance tasks as described in this manual.

UNIT INFORMATION

Record information as shown below.

In the unlikely event that factory assistance is ever required, information located on the unit label will be needed.

Locate the RenewAire unit label found on the outside of the unit.

NOTE: This information is for purposes of identifying the unit-specific option data from the Option Code.

Option Code:

HE1.5JIN - - - - -

Serial Number:

□ □ □ □ □ □ □ □

SO #:

□ □ □ □ □ □

 NOTE: This page is to be completed by the installing contractor. The completed document is to be turned over to the owner after start up.

UNIT INFORMATION



Energy Recovery Ventilator

201 Raemisch Rd Waunakee, WI 53597 (800) 627-4499
renewairesupport@renewaire.com



ETL LISTED
CONFORMS TO
UL STD 818
CERTIFIED TO
CAN/CSA C22.2
No. 113

Option Code HE1.5JINV-S11EE--DGFT--L

Model/Modele HE1.5XIN **Sales Order** 109074

Serial Number K23 100238 C **Job Order** 70425-000 SCCR 5 KAIC

Power Supply to Unit Alimentation d'énergie à l'unité			Motors protected by IEC Style Motor Starters Les moteurs protégés par des de moteur de modèle de IEC	
Voltage	Minimum Circuit Amps	Max Overcurrent Protection Device	(QTY) & W/HP	FLA
115V	18.0	20	None	-
60 HZ 1-Phase	Amp. Minimales de Circuit	Dispositif de protection maximum contre les surintensités	(QTY) & W/CV	APC
Motors Thermally Protected Moteurs protégé thermiquement			Motors Protected by Variable Frequency Drives Les moteurs protégés par la fréquence variable conduit	
(QTY) & W/HP	FLA	(QTY) & W/HP	FLA	
2@1.0 HP	8.0	None	-	
(QTY) & W/CV	APC	(QTY) & W/CV	APC	



⚠ WARNING ⚠ AVERTISSEMENT

Danger of electric shock. Always disconnect power source before servicing. Do not install in a cooking area or make line-voltage electrical power connections directly between this unit and any appliance.
Danger de choc électrique. Toujours déconnecter la source d'alimentation avant les réparations. N'installez pas de zone cuisine ou de ligne de tension les connexions d'alimentation électrique directement entre cette unité et tout.

030137_001

UNIT LABEL (TYPICAL)

1.0 OVERVIEW	7		
1.1 DESCRIPTION	7		
1.2 AIRFLOW	8		
2.0 COMPONENT DESCRIPTIONS	8		
2.1 CABINET	8		
2.2 ENTHALPIC CORES	8		
2.3 FAN/MOTOR ASSEMBLIES.....	8		
2.4 E-BOX	8		
2.5 FILTERS	9		
2.6 FACTORY INSTALLED OPTIONS.....	9		
3.0 SHIPPING/RECEIVING/HANDLING	9		
3.1 UNIT WEIGHTS AND DIMENSIONS	9		
3.1.1 Unit Dimensions and Weight	9		
3.1.2 Shipping Dimensions and Weight.....	9		
3.2 RIGGING AND CENTER OF GRAVITY	10		
3.2.1 HE1.5XINH Hoisting Weights and COG	10		
3.2.2 HE1.5XINV Hoisting Weights and COG	10		
3.3 RECEIVING	10		
3.4 STORAGE	11		
4.0 UNIT PLACEMENT	11		
4.1 BEFORE YOU BEGIN	11		
4.2 SERVICE CLEARANCES	11		
4.3 SOUND ATTENUATION.....	12		
4.3.1 Outside the Building.....	12		
4.3.2 Ducts	12		
4.3.3 Radiated Noise	12		
5.0 INSTALLATION	12		
5.1 DUCTWORK	12		
5.1.1 Ducts to the Outside.....	12		
5.1.2 Inside Ductwork System.....	12		
5.2 FLOOR INSTALLATION.....	12		
5.3 SUSPENDED MOUNT	13		
5.4 ELECTRICAL REQUIREMENTS.....	13		
5.4.1 Electronically Commutated Motors	13		
5.4.2 Low Voltage Control System	13		
5.4.3 How to Reset the 24 VAC Circuit Breaker	14		
5.4.4 Limits of Power Output	14		
5.5 WIRING SCHEMATICS.....	15		
5.6 EXTERNAL CONTROL CONNECTIONS.....	17		
5.6.1 Single 2-Wire Control, Unpowered.....	17		
5.6.2 Control Sending 24 VAC “On” Signal	17		
5.6.3 Control System with Two Non-Powered Relay Contacts:	17		
5.6.4 Control System Sending two 24 VAC “On” Signals (from an external power source)	18		
5.6.5 Control Operating on Unit’s 24 VAC Power Supply.....	18		
5.6.6 Control System Operating Isolation Dampers with End Switches.....	18		
5.7 QUICK-START FOR TESTING CORRECT 3PH WIRING	19		
5.8 FIELD CONVERSION OF OPENINGS.....	19		
5.8.1 To Field Convert the Inlet Opening	19		
5.8.2 To Field Convert the Outlet Opening	20		
6.0 OPERATION	21		
6.1 PRINCIPLE OF OPERATION	21		
6.2 PRE-START UP	21		
6.2.1 Verify Voltages.....	21		
6.2.2 Verify Transformer Wiring	21		
6.2.3 Inspect Filters	21		
6.2.4 Inspect Foam Gasketing.....	21		
6.2.5 Inspect Fans.....	21		
6.2.6 Inspect and Clean the Cabinet Interior	21		
6.2.7 Inspect Ductwork Connections.....	21		
6.3 UNIT START UP.....	22		
6.3.1 Fixed-Speed Units	22		
6.4 BALANCING AIRFLOW	22		
6.4.1 Filter Pressure Drop.....	23		
6.5 NORMAL OPERATION	24		
6.6 OPERATION IN EXTREME COLD WEATHER	24		
7.0 MAINTENANCE	24		
7.1 MAINTENANCE 24 HRS. AFTER START UP	24		
7.2 MAINTENANCE 30 DAYS AFTER START UP.....	24		
7.3 MAINTENANCE SCHEDULE.....	24		
7.4 FILTERS	25		
7.5 FAN MOTOR.....	25		
7.6 ENTHALPIC CORE	25		
7.6.1 Enthalpic Core Maintenance	25		
7.6.2 Enthalpic Core Removal	25		
7.6.3 Enthalpic Core Replacement.....	25		
7.7 MAINTENANCE RECORDS	26		
7.8 SERVICE PARTS.....	27		
8.0 TROUBLESHOOTING	27		
9.0 FACTORY ASSISTANCE	27		

TABLE OF ILLUSTRATIONS

Figure 1.2.0 Airflow Orientations.....	8
Figure 3.2.0 HE1.5XINH Weights and COG	10
Figure 3.2.1 HE1.5XINV Weights and COG	10
Figure 4.2.0 HE1.5XINH Service Clearance.....	11
Figure 4.2.1 HE1.5XINV Service Clearance	11
Figure 5.5.0 HE1.5XIN Single Phase Unit, Standard	15
Figure 5.5.1 HE1.5XIN Three Phase Unit, Standard	15
Figure 5.5.2 HE1.5XIN Single Phase Unit, with Independent Blower Control.....	16
Figure 5.5.3 HE1.5XIN Three Phase Unit, with Independent Blower Control	16
Figure 5.6.0 A Switch or Non-Powered Control Using Unit's 24 VAC Power Supply.....	17
Figure 5.6.1 24 VAC from an External Source	17
Figure 5.6.2 Two External Non-Powered Relay Contacts.....	17
Figure 5.6.3 Two External Relay Contacts Supplying 24 VAC from an External Source	18
Figure 5.6.4 An External Control Using Unit's 24 VAC Power Supply	18
Figure 5.7.0 Example of Converting Openings.....	20
Figure 6.4.0 HE1.5XINH Pressure Port Locations, Typical.....	22
Figure 6.4.1 Initial Pressure Drop of MERV 8 Filters, Supplied with this Unit.....	23
Figure 6.4.2 Initial Pressure Drop of MERV 13 Filters, Available as an Accessory.....	23
Figure 7.8.0 HE1.5XIN Service Parts.....	27

CONFIGURATION CODE

NOTE: Not all options are available on every model.

MODEL NUMBER	H	E	1	.	5	J	I	N							-	-							-		
DIGIT NUMBER	1	2	3	4	5	6	7	8	9	10	11	12	13	14	15	16	17	18	19	20	21	22	23	24	25

Digits 1-5:	Model
"HE07-", "HE10-", "HE1.5", "HE-2X", "HE-3X", "HE-4X", "HE-6X", "HE-8X"	

Digits 7-8:	Location
"IN" = Indoor "RT" = Rooftop	

Digit 9:	Orientation (see Restriction 1)
"V", "H" (Indoor Units) "V", "H", "R", "F", "C" (Rooftop Units)	

Digit 11:	Wall Type
"S" = Single "D" = Double	

Digit 12:	Phase (See Restriction 2, 8, 11, & 20)
"1" = Single Phase "3" = Three Phase	

Digit 13:	Voltage (see Restrictions 3, 4, 5, 6, 7, 11, 19, & 26)
"1" = 120V "4" = 460V "5" = 208-230V "8" = 575V "9" = 277V	

Digit 14:	FA Horsepower (see Restrictions 7, 8, 9, 10, 21, & 25)
"E" = EC Direct Drive Motors (HE07-, HE-10-, and HE1.5 only) "A" = Advanced EC Direct Drive Motorized Impellers (HE07- and HE10- only) "B" = Intermediate EC Direct Drive Motorized Impellers (HE07- only) "S" = Standard Impellers (HE1.5 only) "U" = 1.5HP (HE-2X only) "V" = 2HP (HE-2X, HE-3X, HE-4X only) "W" = 3HP (HE-3X, HE-4X, HE-6X, HE-8X only) "X" = 5HP (HE-3X, HE-4X, HE-6X, HE-8X only) "Y" = 7.5HP (HE-6X, HE-8X only) "Z" = 10HP (HE-8X only)	

Digit 15:	EA Horsepower (see Restrictions 7, 8, 9, 10, 21, & 25)
"E" = EC Direct Drive Motors (HE07-, HE-10-, and HE1.5 only) "A" = Advanced EC Direct Drive Motorized Impellers (HE07- and HE10- only) "B" = Intermediate EC Direct Drive Motorized Impellers (HE07- only) "S" = Standard Impellers (HE1.5 only) "U" = 1.5HP (HE-2X only) "V" = 2HP (HE-2X, HE-3X, HE-4X only) "W" = 3HP (HE-3X, HE-4X, HE-6X, HE-8X only) "X" = 5HP (HE-3X, HE-4X, HE-6X, HE-8X only) "Y" = 7.5HP (HE-6X, HE-8X only) "Z" = 10HP (HE-8X only)	

Digit 18:	Flow Control* (see Restrictions 12, 13, & 14)
" " = No Isolation Dampers (with no Bypass) "D" = Motorized Damper both Airstreams (with no Bypass) "E" = Motorized Damper EA or RA Airstream (with no Bypass) "F" = Motorized Damper FA or OA Airstream (with no Bypass) "S" = Backdraft Damper OA Airstream (with no Bypass) "R" = Backdraft Damper EA Airstream (with no Bypass) "B" = Backdraft Damper both Airstreams (with no Bypass) "T" = Motorized Damper OA, Backdraft Damper EA (with no Bypass) "O" = Dry Bulb Face and Bypass Dampers only "1" = Dry Bulb Bypass with Motorized Dampers all Airstreams "4" = Dry Bulb Bypass with Backdraft Damper OA Airstream "5" = Enthalpy Face and Bypass Dampers only "6" = Enthalpy Bypass with Motorized Dampers all Airstreams "9" = Enthalpy Bypass with Backdraft Damper OA Airstream	

Digit 19:	Unit Control (see Restrictions 15, 16, 17, 18, 19, 20, 21, 24, & 27)
"A" = Standard Unit Control Wiring "D" = Independent Blower Control (HE1.5 only) "V" = Onboard VFD Both Airstreams with IE3 Premium Efficiency Motors "W" = Onboard VFD Both Airstreams with IE5+ Ultra Premium Efficiency Motors "G" = Terminal Strip for EC Motors or Impellers	

Digit 20:	Disconnect
"N" = Non-Fused (Standard) "F" = Fused	

Digit 21:	Unit Control Enhancements (see Restrictions 16 & 22)
"T" = Transformer with Isolation Relay (Standard) "1" = Enhanced Controls "2" = Premium Controls "3" = Enhanced Controls with BACnet License "4" = Premium Controls with BACnet License	

Digit 22:	Filter Options (see Restriction 22)
" " = None (Standard) "F" = Filter Monitor Both Airstreams	

Digit 23:	Other Options
" " = None (Reserved)	

Digit 24:	Paint and Customization
" " = None "W" = White Paint "C" = Custom Paint "X" = Custom Unit	

Digit 25:	Safety Listing (see Restriction 23)
"L" = Listed "N" = Non-Listed	

*NOTES:

Digit 6 "J" = G5 Core Type. Digits 10, 16, and 17 are not used in these models.

*Digit 18: For units with the Bypass Option, the face damper also acts as an isolation damper in the EA or RA airstream.

1.0 OVERVIEW

1.1 DESCRIPTION

The HE1.5XIN Energy Recovery Ventilator is a device for recovering both sensible energy (heat) and latent energy (moisture) from the Exhaust Air from an Occupied Space and injecting those energies into an incoming Outside Airstream. It accomplishes this task by forcing the two airstreams through enthalpic cores, where the energy exchange takes place. The two airstreams pass through the enthalpic cores at right angles and the airstreams never mix together. See Section 2.2 Enthalpic Cores in this manual.

Each ERV has two electric blowers, one for each airstream. Fan speeds can be either single speed, or they can have electronically commutated motors. There are a number of different control devices available to control the operation or speed of the unit fans. For further information on available control accessories, see the HE RenewAire catalog.

There are two types of HE1.5X units, one for indoor installations and one for rooftop, or outdoor, installation. This manual is for the HE1.5XIN which is the indoor unit. For information on the outdoor version of this product, see the *HE1.5XRT Installation and Operation Manual*.

These ERVs are commonly installed as part of an air handling system that provides heating and cooling of Supply Air. They can also be installed to operate as stand-alone devices when ducted directly to and from the Occupied Space.

Each HE1.5XIN unit is available in either a horizontal or a vertical model. The difference between the two models is in the airflow/ducting configuration. Horizontally ducted units are identified by the model name HE1.5XINH and vertically ducted units are identified as model HE1.5XINV.

Each unit has an integral 24 VAC power supply that is used internally and can also be used as a power source for other optional control devices.

The HE1.5XIN units are low-maintenance, requiring periodic replacement of the air filters and annual vacuuming of the enthalpic cores. See Section 7.0 Unit Maintenance in this manual.



NOTE: This unit is an Energy Recovery Ventilator, or ERV. It is commonly referred to throughout this manual as an ERV.

IMPORTANT

It is important to understand and use the equipment airstream terminology as it is used in this manual. The airstreams are defined as:

- ♦ **OUTSIDE AIR (OA):** Air taken from the external atmosphere and, therefore, not previously circulated through the system.
- ♦ **SUPPLY AIR (SA):** Air that is downstream of the enthalpic cores and is ready for conditioning or for return to the Occupied Space.
- ♦ **RETURN AIR (RA):** Air that is returned to the ERV from a conditioned space.
- ♦ **EXHAUST AIR (EA):** Air that is removed from a heating or cooling appliance or from the Occupied Space and discharged.

1.2 AIRFLOW

There are two different airflow options for the HE1.5XIN. They are:

- HE1.5XINH
- HE1.5XINV

The airflow configuration is indicated by digit 9 of the Configuration Code.

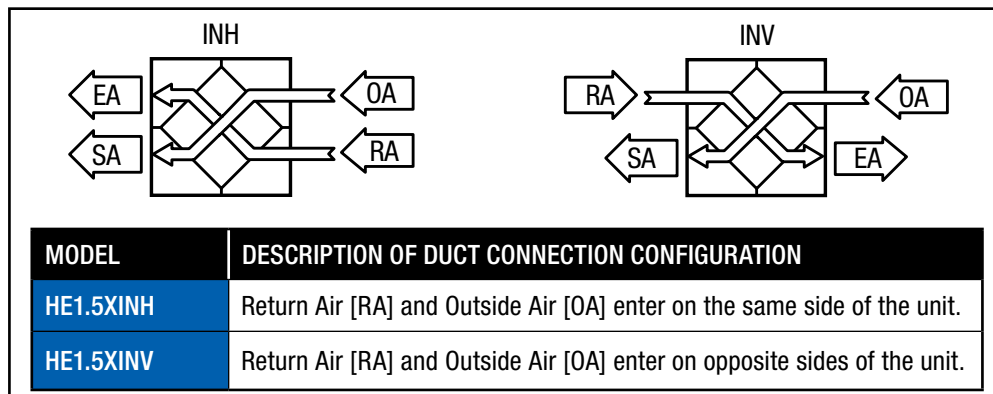

FIGURE 1.2.0 AIRFLOW ORIENTATIONS

2.0 COMPONENT DESCRIPTIONS

2.1 CABINET

The cabinet for the HE1.5XIN is made of 20 gauge galvanized steel and has 1" thick high-density, foil-backed insulation on the inside. Units are available in either single-wall or double-wall construction. Doors are hinged and are fitted with stainless steel machine screws through the faces to prevent accidental opening of the doors when the unit is in operation. Doors may be completely removed by removing the hinge pins. All units are equipped with adjustable-height leveling legs for purposes of leveling the unit. Duct flanges are provided at all four airstream openings for connection of field-supplied ductwork.

⚠ CAUTION

Low airflow can cause fouling of the enthalpic cores. The ERV must never be operated without clean filters in place and minimum airflow must be greater than 250 CFM per full-sized core.

2.2 ENTHALPIC CORES

All HE1.5XIN ERVs use a static-plate enthalpic core. The enthalpic cores transfer both latent and sensible energies between the airstreams. Gasketing is pre-installed on the cores and must be positioned to provide a proper air seal. For information on annual maintenance of the cores, see Section 7.0 Maintenance in this manual.

2.3 FAN/MOTOR ASSEMBLIES

There are two fan and motor assemblies in each ERV.

2.4 E-BOX

Every HE1.5XIN is equipped with what is known as an "E-Box." High-voltage supply wiring and low-voltage control wiring is all terminated here. If optional integrated programmable controls are installed, an additional 24 VAC transformer is installed here to power both the controller and its dedicated sensors.

2.5 FILTERS

All HE1.5XIN units come equipped with four MERV 8 pleated filters. MERV 13 filters can be ordered as an accessory and are shipped loose.

- (2) 14" x 20" x 2" and (2) 16" x 20" x 2" (nominal) pleated filters. Actual size: 13.5" x 19.5" x 1.75" and 15.5" x 19.5" x 1.75"
- Minimum recommended effectiveness: MERV 6.

2.6 FACTORY INSTALLED OPTIONS

All HE1.5XIN units can be ordered with factory installed options. See Unit Configuration Code on page 10.

Options will have supplemental manuals shipped with the unit.

For EC Motor option, see *EC Motor Supplemental Manual*.

For Commercial Controls, see *Commercial Controls Supplemental Manual*.

For Filter Alarm, see *Filter Alarm Supplemental Manual*.

For Economizer/Bypass, see *Bypass Economizer Supplemental Manual*.

For Isolation Dampers, see *Isolation Dampers Supplemental Manual*.

3.0 SHIPPING/RECEIVING/HANDLING

HE1.5XIN units are palletized at the factory and then shipped by common carrier. Upon receipt by the installer, the shipment should be inspected for shipping damage, prior to unloading.

Any discovered shipping damage should be immediately reported to the RenewAire sales rep and the damage must be recorded on the Bill Of Lading, prior to signing for acceptance of the shipment. The unit can be handled with a fork lift or a crane. Prior to moving the unit, verify that all latches and securing bolts on the cabinet doors are tightly fastened.

If a crane is used for moving the HE1.5XIN unit, unscrew the sheet metal plates that hold the adjustable legs to the pallet. Use two hoisting slings and a spreader bar to hoist the unit. The hoisting slings must be positioned around the ends of the unit so they do not touch the unit doors. Unit hoisting weights and Center of Gravity are detailed in Sections 3.1 and 3.2 in this manual.

Perform a test lift to make sure the unit is being hoisted level and is secure.

Place the HE1.5XIN unit on a flat surface where it will be protected from the weather and incidental damage. Do not remove protective coverings from any duct openings and keep the doors secured and tightly closed.

3.1 UNIT WEIGHTS AND DIMENSIONS

3.1.1 Unit Dimensions and Weight

HE1.5XINH: 48 3/4" L x 34 1/2" W x 53 3/4" H
337-504 lbs., varies by option(s)

HE1.5XINV: 59 1/2" L x 34 1/2" W x 46 1/4" H
337-504 lbs., varies by option(s)

3.1.2 Shipping Dimensions and Weight

HE1.5XINH: 70" L x 47" W x 53" H
571 lbs.

HE1.5XINV: 70" L x 47" W x 59" H
571 lbs.

3.2 RIGGING AND CENTER OF GRAVITY

3.2.1 HE1.5XINH Hoisting Weights and COG

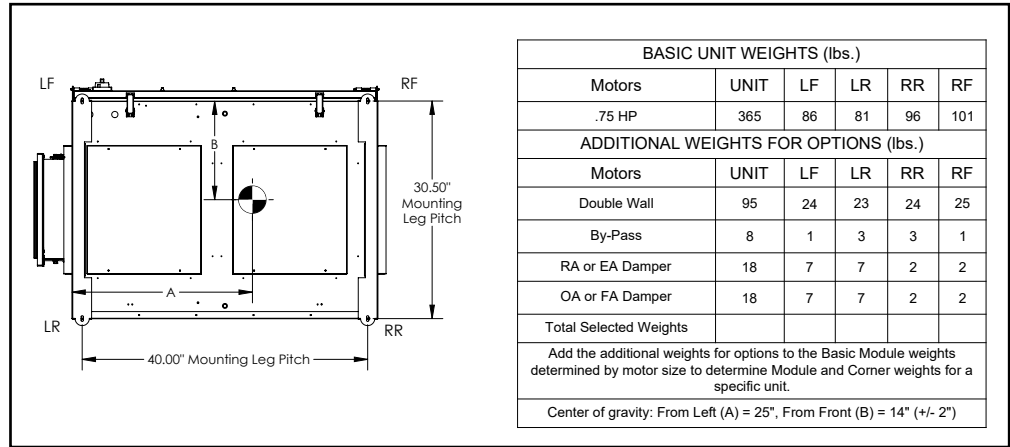

FIGURE 3.2.0 HE1.5XINH WEIGHTS AND COG

3.2.2 HE1.5XINV Hoisting Weights and COG

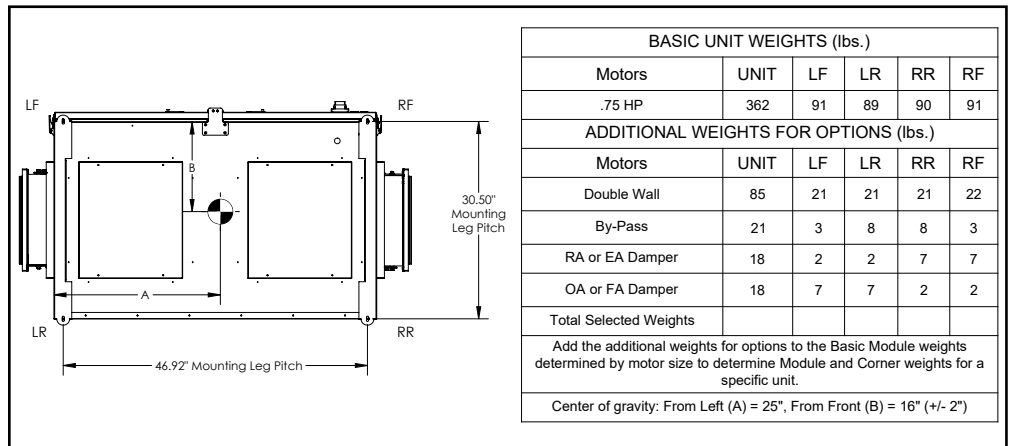

FIGURE 3.2.1 HE1.5XINV WEIGHTS AND COG

3.3 RECEIVING

Upon receipt of the HE1.5XIN, inspect the unit for obvious external damage. If damage is observed, take digital pictures and report the damage to your RenewAire representative. Note the damage on the carrier’s Bill of Lading. Depending on expected transport and storage conditions, the unit may have only the duct openings covered, it may be stretch-wrapped or it may be crated. Do not unwrap the unit at this time. The unit will normally be moved to its final location while still wrapped and attached to its pallet.

The preferred method of hoisting the HE1.5XIN from the carrier truck is by using a construction forklift.

Once the unit is unwrapped, prevent dirt and debris from entering the cabinet by covering any duct openings that do not have attached dampers. Keep the duct openings covered until it’s time to connect ductwork.

3.4 STORAGE

Units that must be stored prior to installation should be left on their pallets and protected from weather and physical damage. Units must be placed on a level surface to prevent warping of the pallet and the HE1.5XIN. All access doors must be secured with all available hardware (door latches and securing bolts) and all openings into the cabinet must be sealed to prevent entry of dust, dirt and debris.

4.0 UNIT PLACEMENT

4.1 BEFORE YOU BEGIN

Units that must be stored prior to installation should be left on their pallets and protected from weather and physical damage. Units must be placed on a level surface to prevent warping of the pallet and the HE1.5XIN. All access doors must be secured with all available hardware (door latches and securing bolts) and all openings into the cabinet must be sealed to prevent entry of dust, dirt and debris.

The HE1.5XIN is designed for installation in a sheltered location, out of the weather. The preferred mounting location is to place the unit on a concrete floor, although it can also be suspended from a ceiling or other structural support. See Section 5.3, Suspended Mount, in this manual.

For all installations, maintain needed service clearances as shown on the dimensioned drawings located in Section 4.2 of this manual. In addition, if the optional Bypass Economizer is ordered, additional clearance will be required for the extra bypass duct. See the RenewAire Supplemental Manual for Bypass or further information and clearance details specific to the HE1.5XIN units.

For all floor-mount installations, the unit should be set on its factory-provided adjustable legs and leveled. Select a location that is central to the inside duct runs and close to both the exhaust duct (to the outside) and also to the Supply air duct (from the outside).

The exhaust outlet and the outside air inlet on the outside of the building should be at least 10' apart to avoid cross-contamination. Comply with all local building codes in the positioning of the duct openings. Do not position the exhaust air outlet in a location where it will dump exhaust air into any enclosed or occupied space. The duct inlets and outlets should be screened against insects and vermin and should be shielded from the weather to prevent entry of rain or snow.

4.2 SERVICE CLEARANCES

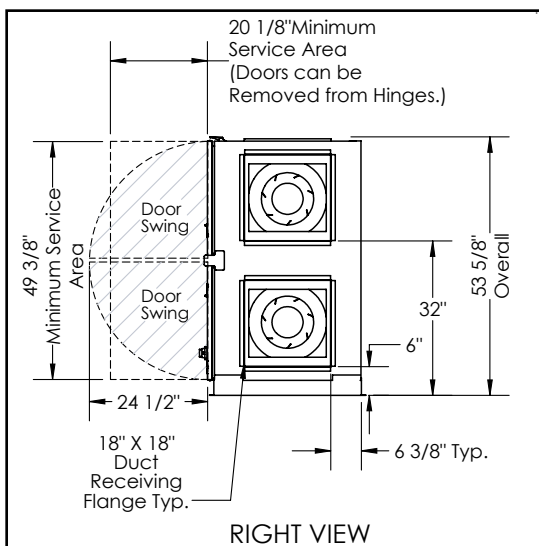

FIGURE 4.2.0 HE1.5XINH SERVICE CLEARANCE

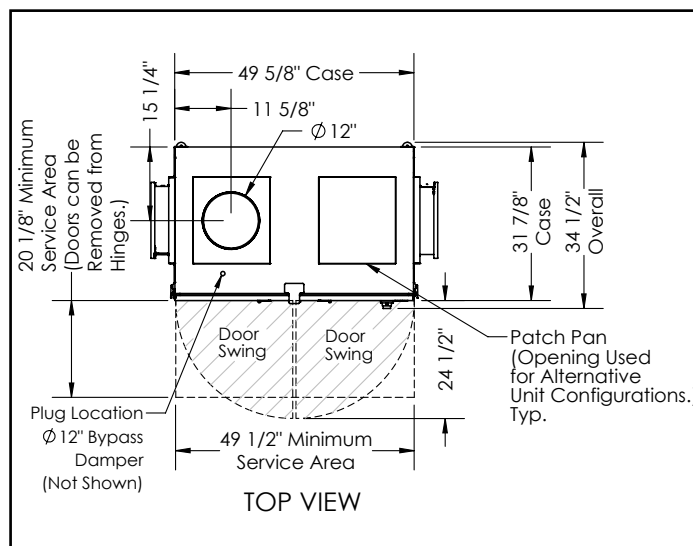

FIGURE 4.2.1 HE1.5XINV SERVICE CLEARANCE

4.3 SOUND ATTENUATION

Take these simple steps to attenuate noise from the unit.

4.3.1 Outside the Building

The exhaust hood is the primary source of noise outside the building. When practical, orient the exhaust air hood to point away from houses or public areas.

4.3.2 Ducts

Make sure the ductwork at the unit outlets is stiff enough to resist the flexure and resulting booming associated with system start up and shut-off, as well as the turbulent flow conditions at the blower outlets.

In general, provide smooth transitions from the ERV's outlets to the duct. The ducts connecting to the outlets should be straight for a sufficient distance, with gradual transitions to the final duct size.

These guidelines are consistent with SMACNA recommended duct layout practices for efficient and quiet air movement. Follow SMACNA guidelines.

4.3.3 Radiated Noise

The HE1.5XIN is insulated with high-density fiberglass. This provides significant attenuation of radiated sound from the unit itself.

The outlet ducts can be significant sources of radiated sound as well. The SA duct should be insulated for sound control. This insulation should start at the unit. At a minimum the first 10' of duct should be insulated. All parts of the SA and RA ducts located in a mechanical space with noise-generating equipment also should be insulated for sound control, both to minimize sound radiation out of the SA duct, and also to control sound radiation into both ducts.

5.0 INSTALLATION

5.1 DUCTWORK

5.1.1 Ducts to the Outside

The exhaust outlet and Supply air inlet on the outside of the building should be at least 10' apart to avoid cross-contamination. The exhaust outlet should not dump air into an enclosed space or any other structure. The inlets and outlets should be screened against insects and vermin and shielded from the weather to prevent the entry of rain or snow.

Ducts connecting the HE1.5XIN to the outside must be insulated, with sealed vapor barrier on both inside and outside of the insulation. Insulate both the Outside Air (OA) and Exhaust Air (EA) ducts.

5.1.2 Inside Ductwork System

Ensure Good Ductwork Design:
Ductwork should be designed to allow the unit to provide the required airflow and reduce pressure drop for efficient, quiet operation. If the inside ducts run through unconditioned spaces they must be insulated with a sealed vapor barrier on both inside and outside of insulation.

5.2 FLOOR INSTALLATION

Most units are installed in a location specified by others. In general, it is preferable to install the unit on a flat, reasonably level surface, such as a concrete floor. When positioning the unit, it is not to be slid on its legs because they can be bent.



NOTE: Ducts inside a building that are connected to the outside must be insulated with a sealed vapor barrier on both the inside and the outside of the insulation.

CAUTION

Tape both inner and outer vapor barriers of insulated duct to collars on duct adapters. This is critical to prevent migration of moisture into insulation. Build-up of moisture can result in failure of the duct system and/or frost in the insulation. Make sure any tears in the inner and outer vapor barriers are sealed.

5.3 SUSPENDED MOUNT

HE1.5XIN units can also be suspended from a ceiling or other structural member. Screw or bolt mounting straps or brackets directly to the sheet metal case as necessary. Remove the access doors before installing screws—make sure your fasteners do not damage internal parts. Do not screw into the access doors.

Install 3/8-16" bolts through the channels, into the bottom of the unit. Support the channels from threaded rods, located in an appropriate location that maintains required service clearances.

5.4 ELECTRICAL REQUIREMENTS

Electrical Options and Ratings are identified on the Unit Label (located near electrical box). Find the complete Unit Model Number in the lower left corner of the Unit Label.

⚠ CAUTION

Before bringing power to the unit check unit nameplate to confirm it matches the voltage and phase of the power you are supplying. Remember that your field connections need to be accessible for inspection.

5.4.1 Electronically Commutated Motors

These ERVs may be ordered with factory-installed features including Electronically Commutated (EC) Motors. Consult the *EC Motor Supplemental Manual* for more information.

Electrical Options are identified on the Unit Label located near electrical box on the outside of the unit. Find the complete Unit Model Number in the lower left corner of the Unit Label. Use the configuration chart to determine motor power and voltage installed in your HE1.5XIN.

Use conduit, strain reliefs, etc. as required by code to secure the field wiring. Electrical knockouts are provided for alternate line voltage and voltage control locations for field wiring to the internal electrical box. If the alternate sites are desired for field wiring then carefully remove the knockout plugs and foam insulating plugs from the alternate sites and install them in the open knockout locations.

5.4.2 Low Voltage Control System

This ERV is provided with a Class II 24 VAC power supply system that operates the unit's contactor(s) for HE1.5XIN. The ERV's 24 VAC Power Supply can also be used to power the externally-installed controls system: up to 8 VA of power is available.

The unit's power supply system includes isolation relay(s) so you can use external controls whose contact ratings are as low as 50 mA (1.2 VA). Also, it is possible to operate the isolation relays with 24 VAC power from an external source (with proper wiring connections).

A built-in circuit-breaker prevents damage to the transformer and other low-voltage components in the event of a short-circuit or overload. In extreme cases, the transformer itself is designed to fail safely.

Specifications:

- Nominal Output Voltage under load: 24 VAC
- Typical Output Voltage at no load: 29–31V
- Minimum contact rating for connected control device: 50 mA (1.2 VA)
- Circuit Breaker Trip Point: 3A



NOTE: It is the installer's responsibility to select appropriate materials capable of safely supporting the weight of the ERV and all attached hardware, such as ductwork. It is the installer's responsibility to determine the location of the ERV and the needed supporting threaded rods. All such installations must be reviewed and approved by an engineer.



NOTE: If your unit is equipped with EC Motors, please refer to "EC Motor Supplemental Manual" for more detail.
Use conduit, strain reliefs, etc. as required by code to secure the field wiring.



NOTE: Standard HE1.5XIN with single phase original equipment motors are NOT suitable for use with solid state speed control.



NOTE: Le HE1.5XIN avec moteurs d'équipement d'origine monophasés sont adaptés pour une utilisation avec régulateur de vitesse électronique.

NOTICE

If primary-side voltage is 230 VAC, move black primary-side lead from transformer's "208 V" terminal to the transformer's terminal marked "240 V" ("230 V" in some units). Do not move the black primary-side lead that is connected to the transformer's "COM" terminal.

⚠ CAUTION

Be careful if the external control system provides 24 VAC power at its control output: make sure blue and red leads are separately capped and not connected to any other wires.

⚠ CAUTION

1. Connect only to components intended for use with 24 VAC power.
2. Do not undersize the low-voltage wires connected to this device. Observe the wire length and gauge limits indicated in this manual.
3. Do not overload this unit's 24 VAC power supply system. Confirm that the power requirements of devices you connect to this power supply system do not exceed 8 VA in total.
4. If an external source of 24 VAC power is used to control the unit, consult the wiring schematics and connect the external power only to the specified terminals in order to avoid damaging the unit or external controls. Connect only CLASS II power to the control terminals of this unit.
5. Unit is not equipped to receive analog signals (such as 1–10 vdc or 4–20 mA).

5.4.3 How to Reset the 24 VAC Circuit Breaker

If the transformer is subjected to an excessive load or a short circuit, the circuit breaker will trip to prevent the failure of the transformer. When it trips the circuit breaker's button pops up. Shut off the primary-side power to the unit, and remove the excessive load or the short. The circuit breaker can be reset about fifteen seconds after it trips by pressing in the button.

5.4.4 Limits of Power Output

If limits on wire gauge and length are observed, you may connect control devices that draw up to 8 VA to the blue and red wires. More than one device can be connected as long as total steady-state load does not exceed 8 VA.

Wire Gauge	#22	#20	#18	#16	#14	#12
Circuit Length	100'	150'	250'	400'	700'	1000'

"Circuit Length" is distance from ERV to Control Device.

Observe these limits to wire length and gauge in order to ensure reliable operation of the control system.

5.5 WIRING SCHEMATICS

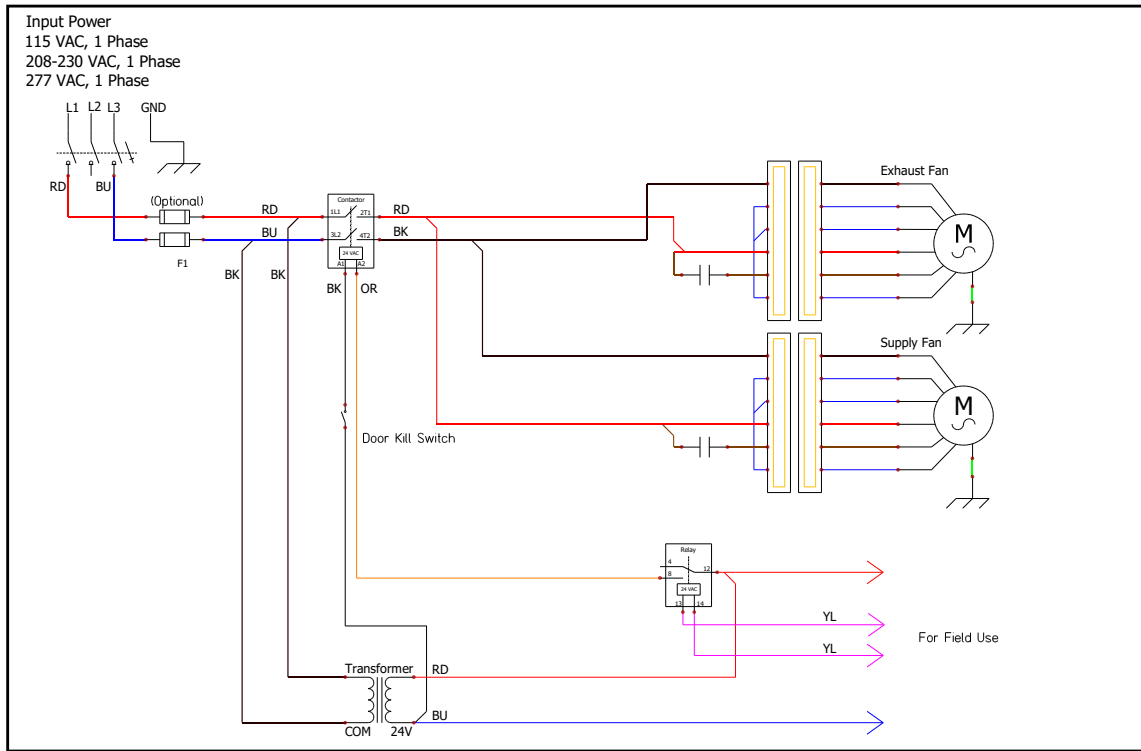

FIGURE 5.5.0 HE1.5XIN SINGLE PHASE UNIT, STANDARD

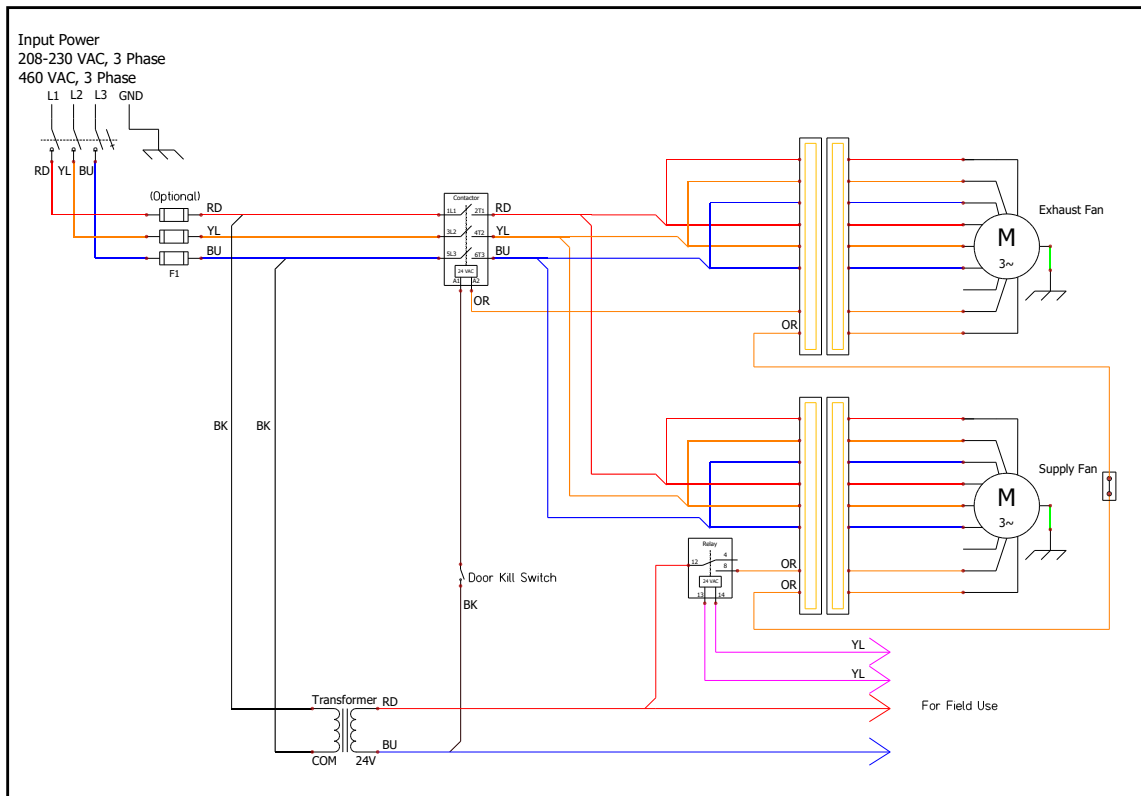

FIGURE 5.5.1 HE1.5XIN THREE PHASE UNIT, STANDARD

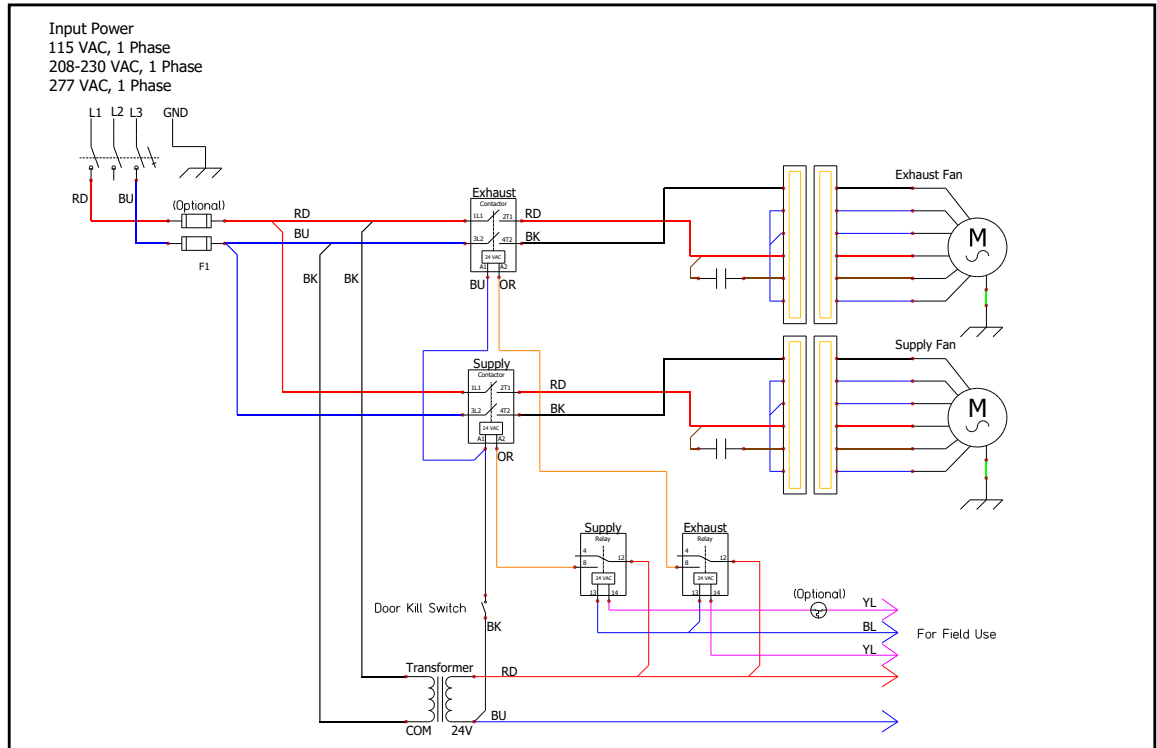

FIGURE 5.5.2 HE1.5XIN SINGLE PHASE UNIT, WITH INDEPENDENT BLOWER CONTROL

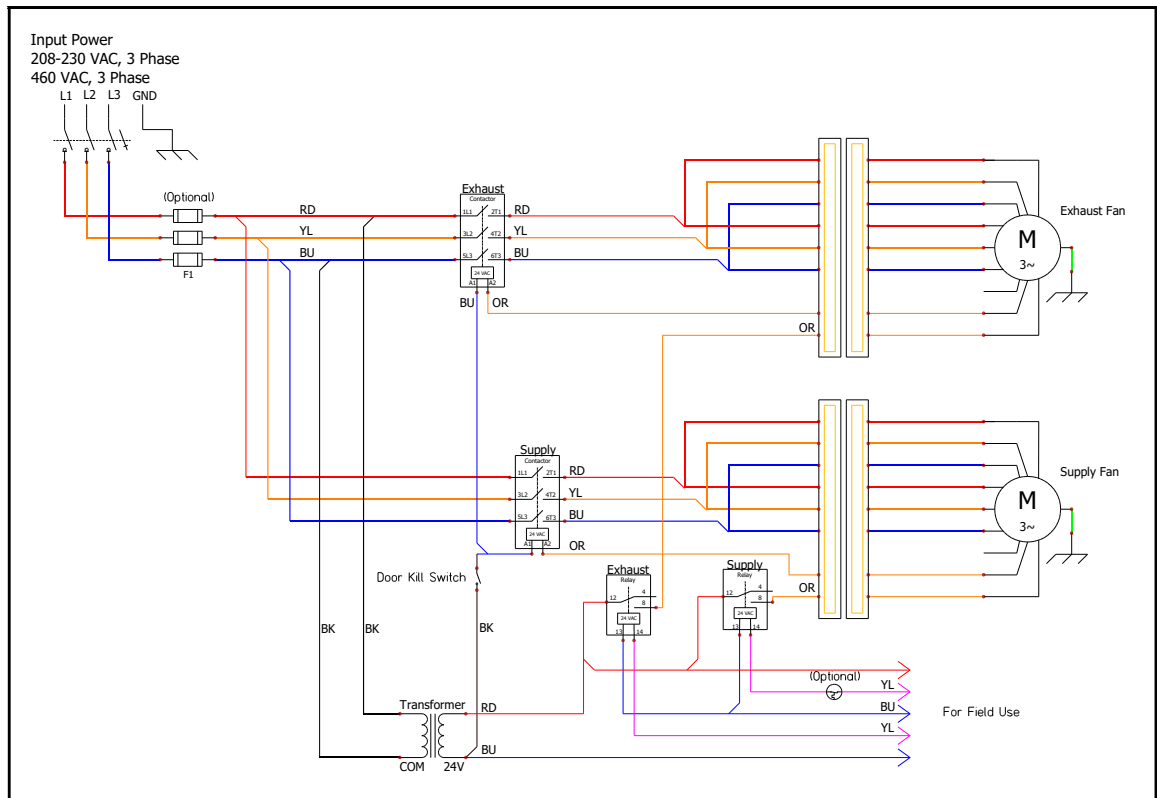

FIGURE 5.5.3 HE1.5XIN THREE PHASE UNIT, WITH INDEPENDENT BLOWER CONTROL

5.6 EXTERNAL CONTROL CONNECTIONS

5.6.1 Single 2-Wire Control, Unpowered

Use the schematic shown in Figure 5.6.0 if the control requires no power to operate and acts like a simple on/off switch. The control must not supply any power to the ERV unit.

- Connect the blue lead to one yellow lead.
- Connect the control’s contacts to the red lead and the remaining yellow lead.

Control on separate Power Supply, no power present at Control Output:

Wire as shown for the Single 2-wire control.

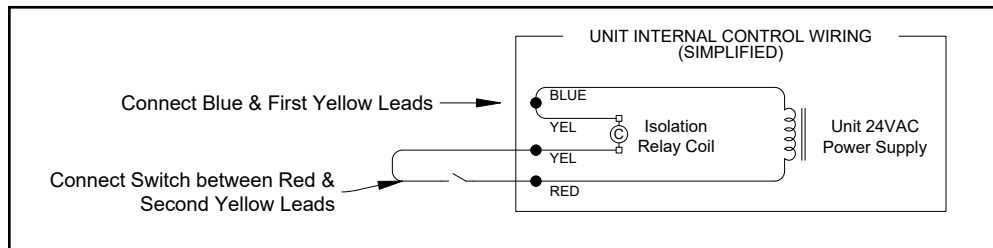

FIGURE 5.6.0 A SWITCH OR NON-POWERED CONTROL USING UNIT'S 24 VAC POWER SUPPLY

5.6.2 Control Sending 24 VAC “On” Signal

Use the schematic shown in Figure 5.6.1 if a 24 VAC “On” signal is to be sent from an external power source to the ERV.

- Make sure the blue and red leads are separately capped and not connected to any other wires.

Now you safely can apply 24 VAC to the two yellow leads to operate the ERV’s isolation relay.

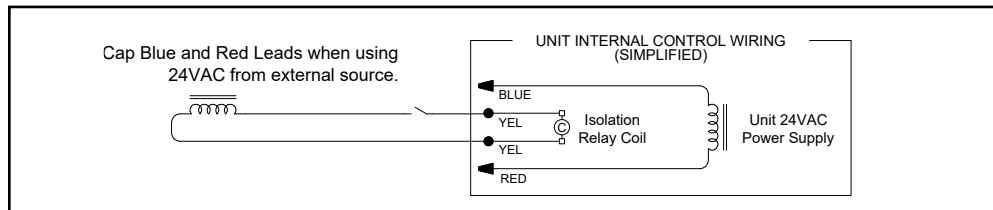

FIGURE 5.6.1 24 VAC FROM AN EXTERNAL SOURCE

5.6.3 Control System with Two Non-Powered Relay Contacts:

ERVs with Independent Blower Control Only:

Use Figure 5.6.2 if the external control system provides no voltage or current at its output contacts.

- Connect the two blue leads together.
- Connect the red lead to one side of each of the output contacts.
- Connect the other side of the output contacts to the appropriate yellow leads: marked “SA Blower” and “EA Blower.”

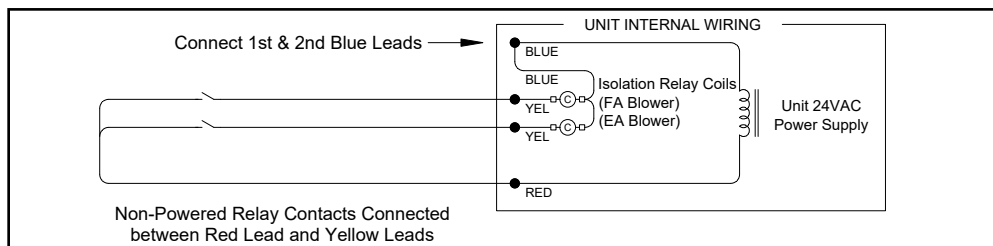

FIGURE 5.6.2 TWO EXTERNAL NON-POWERED RELAY CONTACTS

NOTE: The simplified schematics below show only the relevant portions of the low-voltage control circuit in the ERV unit and representational external control approaches. See the complete unit schematics above.

CAUTION
Make sure the control provides no voltage or current at its output terminals.

CAUTION
Supply only 24 VAC (not VDC) from a Class II Power Source.

5.6.4 Control System Sending two 24 VAC “On” Signals (from an external power source)

Use Figure 5.6.3 only if the ERV has Independent Blower Control:

- Make sure the blue and red leads are separately capped and not connected to any other wires.

Now you safely can apply one of the 24 VAC signals to one of the ERV’s yellow leads (marked “SA Blower” and “EA Blower”) and the blue lead to operate one of the ERV’s isolation relay.

- Supply the second 24 VAC signal to the other yellow lead and again to the blue lead (make sure the polarity of each wire connected to the blue lead is the same).

CAUTION
Supply only 24 VAC (not VDC) from a Class II Power Source.

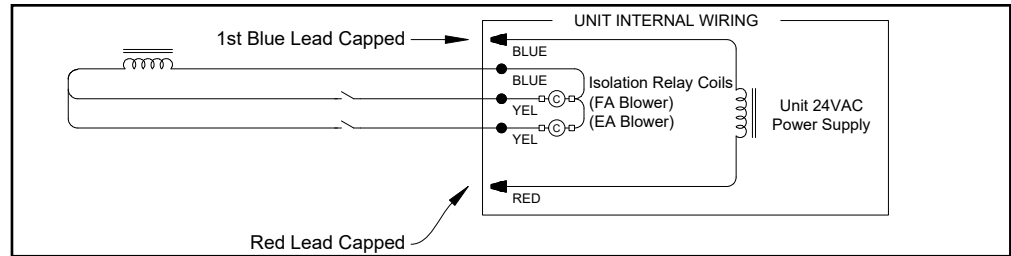

FIGURE 5.6.3 TWO EXTERNAL RELAY CONTACTS SUPPLYING 24 VAC FROM AN EXTERNAL SOURCE

5.6.5 Control Operating on Unit's 24 VAC Power Supply

Use the schematic shown in Figure 5.6.4 if controls are operating on unit's 24 VAC power supply.

- 24 VAC power is available at the blue and red leads.
- Connect one of the yellow leads to the blue lead.
- Connect the switched output of the Control to the red lead to operate the ERV’s isolation relay.

CAUTION
External control system should not draw more than 8 VA.

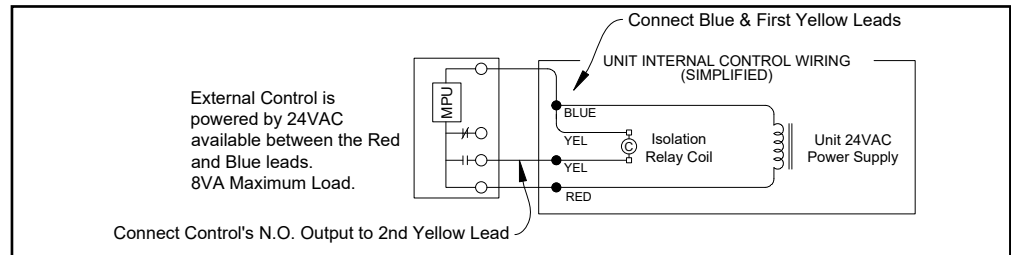

FIGURE 5.6.4 AN EXTERNAL CONTROL USING UNIT'S 24 VAC POWER SUPPLY

NOTE: Because the ERV’s contactors will only be operating once the Dampers are open, the power draw of the Damper Actuators is allowed to be as much as 35 VA while opening (including power draw of the external control system, if any). However the power draw of the fully-opened (stalled) Actuators (and external control system if any) must be less than 8 VA

5.6.6 Control System Operating Isolation Dampers with End Switches

Use Isolation Dampers with electrically separate end switches. The end switches are used to separately control the ERV unit’s Isolation Relays. Also, specify the ERV with Independent Blower Control. This ensures that each damper is open before the respective blower starts up.

5.7 QUICK-START FOR TESTING CORRECT 3PH WIRING

All units that run on 3 phase power should be test-run immediately after high voltage wiring connections are made. This will verify that the three phases are properly connected, that the dampers will open and close properly and the fans are working properly.

For purposes of testing correct phase connections, the internal 24 VAC power supply will be used to power-up the fans and all external control devices will be disabled, when applicable.

5.8 FIELD CONVERSION OF OPENINGS

The HE1.5XIN is designed to allow field conversion of the unit openings. This means the motorized impeller sub-assemblies can be moved to an adjacent wall of the unit if that opening is preferred. The outlet openings can also be moved to an adjacent wall.

Before you start, plan the duct work layout. Determine which openings are to be converted.

- ♦ Turn off the disconnect switch on the unit. Make sure electrical power is shut off to the unit and disconnect switch.
- ♦ Open the access doors to the unit.
- ♦ Remove the core strap, filters, and energy exchanger cores from the unit.

5.8.1 To Field Convert the Inlet Opening

1. Disconnect motor harness connector (A) by the motor. Move the wire harness out of the way if necessary.
2. Support the impeller subassembly. Remove the eight ¼-20 bolts (B) retaining the impeller subassembly plate to the side rails and front and back tabs.
3. Lift the entire impeller subassembly (C) out of the unit and set aside. Leave the rails in the unit.
4. Remove the patch pan (D) from the desired opening.
5. Using the exposed sheet metal cutout, cut the insulation from the desired opening.
6. Seal the edges of the cut insulation to prevent erosion of the insulation edges and having debris in the airstream.
7. Install the patch pan over the undesired opening.
8. Install the insulation in the undesired opening. Seal the insulation.
9. Remove the duct flange from the undesired opening and install it at the desired opening.
10. If both inlet openings are to be converted, repeat Steps 2–9 for the second inlet opening.
11. At this point, if there are outlet openings for conversion, you will want to address them before proceeding with the inlet opening.
12. After converting the outlet openings move the unit floor brackets (E), if necessary, so when the unit is re-oriented the floor brackets support the unit on the floor.
13. Rotate the unit to the desired orientation, if necessary.
14. Install the impeller subassembly into the new inlet opening and fasten with eight ¼-20 bolts to retain to the side rails and front and back tabs. Make sure the motor harness connector is towards the front of the unit.
15. Connect the motor harness.
16. Repeat Steps 14–15 for other impeller subassembly if required.
17. Tidy up any wire harnesses that were moved making sure motor wires are taut and away from the impeller blades.



NOTE: Any changes to unit low-voltage wiring should be made with the disconnect switch in the OFF position.

5.8.2 To Field Convert the Outlet Opening

1. Remove the patch pan (F) from the desired opening.
2. Using the exposed sheet metal cutout, cut the insulation from the desired opening.
3. Seal the edges of the cut insulation to prevent erosion of the insulation edges and having debris in the airstream.
4. Install the patch pan over the undesired opening.
5. Install the insulation in the undesired opening. Seal the insulation.
6. Remove the duct flange (G) from the undesired opening and install it at the desired opening.
7. If both outlet openings are to be converted, repeat Steps 1–6 for the second outlet opening.
8. If Inlet Openings are being converted return to Step 12 in the “To Field Convert Inlet Opening” instructions.

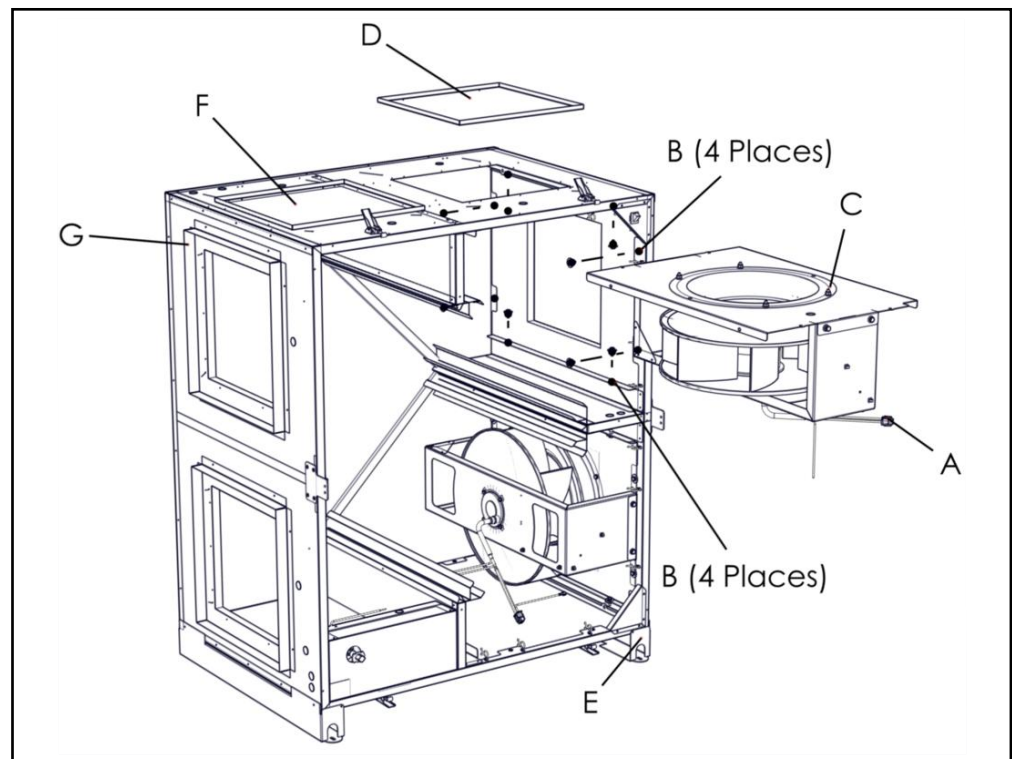

FIGURE 5.7.0 EXAMPLE OF CONVERTING OPENINGS

After completion of the field conversion:

- Clean out the interior of the unit to remove any debris.
- Install energy exchanger cores, filters, and core strap.
- Install access doors on the unit.

6.0 OPERATION

6.1 PRINCIPLE OF OPERATION

The HE1.5XIN has one basic purpose: to exhaust air from a structure and bring in fresh air from outside, while transferring heating or cooling energy from the exhaust air to the fresh air.

The HE1.5XIN is a very simple device, and will accomplish this purpose as long as the blower is able to move air through the enthalpic core.

6.2 PRE-START UP

6.2.1 Verify Voltages

Using a voltmeter, test the input voltages as supplied to the disconnect switch. Refer to Digit 13 of the unit Configuration Code to find the rated voltage. The supplied voltage must be within +/- 10% of the rated voltage.

6.2.2 Verify Transformer Wiring

Units with 230 VAC power source are shipped with the transformer wired for 208 VAC. If the unit is receiving 230 VAC, make sure the black primary-side wire on the transformer's 208 V terminal has been moved to the 230 V terminal.

6.2.3 Inspect Filters

Clean filters must be installed prior to fan start up.

6.2.4 Inspect Foam Gasketing

Inspect the gasketing to make sure there are no gaps allowing air movement around the cores or filters.

6.2.5 Inspect Fans

Prior to start-up and connecting ductwork, when the HE1.5 unit and fans are installed in the desired orientation, check the gap between wheel and inlet ring—it should be consistent all the way around. Spin the blower wheel vigorously to confirm it does not rub. If the inlet ring needs re-adjusting, loosen the 4 bolts and nuts holding the inlet ring and adjust it such that there is a consistent gap between the wheel and inlet ring.

6.2.6 Inspect and Clean the Cabinet Interior

During the construction and installation phases of a project, dust, dirt and debris will often accumulate inside a unit. Thoroughly clean the inside of the unit by vacuuming and/or wiping metal surfaces with a damp rag.

6.2.7 Inspect Ductwork Connections

Ducts attached to the ERV must be firmly attached, sealed and supported in accordance with installation instructions and SMACNA guidelines.

6.3 UNIT START UP

6.3.1 Fixed-Speed Units

Most fixed-speed units do not have any external controlling signals and only require turning on the disconnect switch, located on the E-Box. When the disconnect switch is turned ON, any dampers will first move into their correct operating positions and then power is supplied to the motor contactors, causing the fans to run.

Some fixed-speed units are wired to receive an actuating signal from an external source. If there is an external actuating signal source, verify the type of signal and that it is wired according to the low-voltage wiring diagrams found in Section 5.6 of this manual. Turn on the disconnect switch and then turn ON the actuating device. After any dampers have moved into their correct positions, power is then applied to the motor contactors and the fans will begin running.

IMPORTANT

It is important to balance the airflows after the unit is operational and all ductwork has been installed. Balancing the airflows is typically required by state and/or local codes, and is often specified by the HVAC design engineer.

Optimum efficiency of the enthalpic cores is achieved when the airstreams are properly balanced.



NOTE: ERV airflows are to be balanced after all ductwork is installed. Balancing of airflows is typically required by local or state building codes or by the HVAC design engineer.

6.4 BALANCING AIRFLOW

Equipment Required:

- A magnehelic gauge or other device capable of measuring 0–1.0 in. water of differential pressure.
- 2 pieces of natural rubber latex tubing, 1/8" ID, 1/16" Wall works the best.

The individual differential static pressures (DP) are measured using the installed pressure ports located in the front of the units core access doors.

Do not relocate pressure ports.

Procedure:

- To read SCFM of Supply Air (SA) install the “high” pressure side (+) of your measuring device to the Outside Air (OA) port and the “low” pressure side (-) to the Supply Air (SA) port.
- To read SCFM of Return Air (RA) install the “high” pressure side (+) of your measuring device to the Return Air (RA) port and the “low” pressure side (-) to the Exhaust Air (EA) port.
- Use the reading displayed on your measurement device to cross reference the CFM output using the conversion chart.



NOTE: The tubing should extend in the pressure port approx. 1".



NOTE: These ports are carefully located on the unit to give the most accurate airflow measurement. Do not relocate pressure ports.



NOTE: Make sure clean filters are installed before balancing airflow. Dirty or clogged filters reduce airflow through the unit.

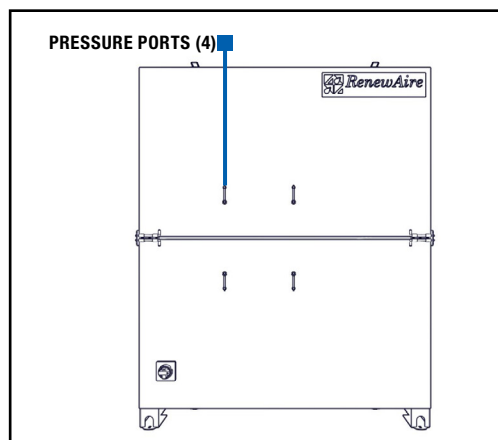

FIGURE 6.4.0 HE1.5XINH PRESSURE PORT LOCATIONS, TYPICAL

DIFFERENTIAL STATIC ACROSS CORE DSP VS. CFM													
HE1.5XIN	DP (H ₂ O)	DSP	.15	.20	.25	.30	.35	.40	.45	.50	.55	.60	.65
	Supply Air (SA)	CFM	380	500	620	740	860	980	1095	1215	1330	1450	1565
	Return Air (RA)	CFM	320	440	565	695	825	960	1095	1235	1375	1515	-

6.4.1 Filter Pressure Drop

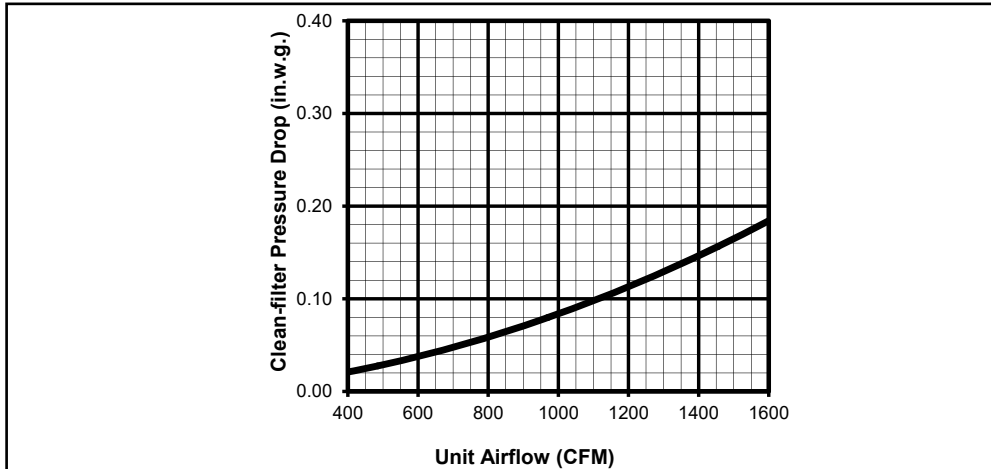



FIGURE 6.4.1 INITIAL PRESSURE DROP OF MERV 8 FILTERS, SUPPLIED WITH THIS UNIT

 NOTE: Clean filter pressure drop is included in unit airflow performance tables.

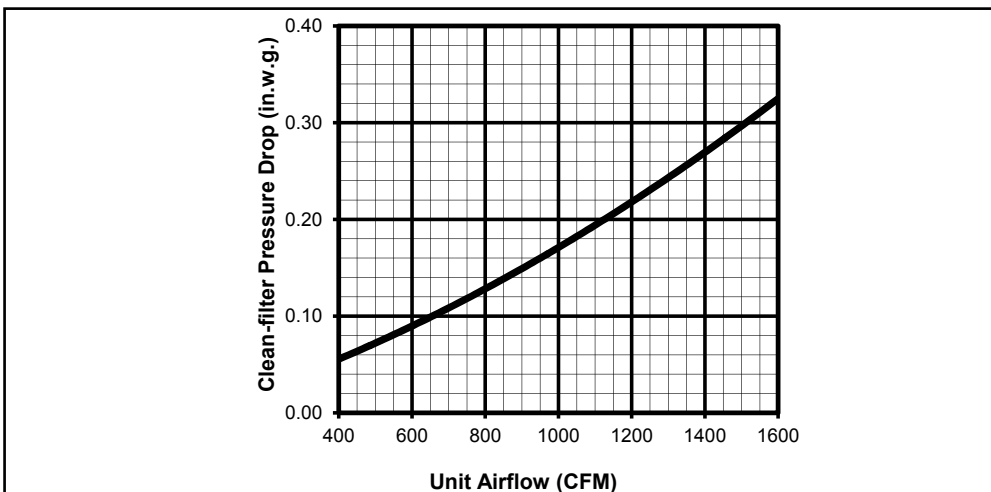

FIGURE 6.4.2 INITIAL PRESSURE DROP OF MERV 13 FILTERS, AVAILABLE AS AN ACCESSORY

6.5 NORMAL OPERATION

A wide variety of control schemes may be selected by the engineer, installer, or owner to meet the ventilation needs of the facility. These may include timer clocks, occupancy sensors, dehumidistats (for cool-weather operation), carbon dioxide sensors, and others. DDC systems may also control the unit. Most control schemes will operate the unit only when needed.

Continuous operation is acceptable in virtually all conditions. Unit will not be damaged by continuous operation as long as airflow occurs. Blower motors may overheat if filters become completely blocked due to lack of maintenance. Motors are thermally protected. With continuous operation, some external frosting may occur in very cold weather (see Section 6.6).

6.6 OPERATION IN EXTREME COLD WEATHER

HE1.5XIN units are capable of operating without internal frosting at temperatures down to -10°F, with indoor humidity below 40%. The units can operate under more severe conditions occasionally with little or no impact on their performance. At lower humidities, they can operate at still lower outside temperatures without freezing the enthalpic cores.

Some condensation or even frost may form on the outside of the unit or drip off the cabinet during very cold conditions, especially if the unit runs continuously. Exterior condensation during extreme cold conditions can be reduced or prevented by periodically cycling the unit OFF for several minutes to allow the cabinet to warm up.

7.0 MAINTENANCE

RenewAire ERVs are built to operate with minimal maintenance. After unit commissioning, the primary areas of attention are the air filters and annual vacuuming of the enthalpic cores.

7.1 MAINTENANCE 24 HRS. AFTER START UP

24 hours after unit start up:

- In new installations, check the air filters since they will often collect dust, dirt and debris at time of start up.

7.2 MAINTENANCE 30 DAYS AFTER START UP

After 30 days of operation:

- Tighten all electrical connections.
- Check the air filters as part of the normal monthly maintenance.

7.3 MAINTENANCE SCHEDULE

Experience on the part of the service person is the most important issue in establishing a maintenance schedule. There will be times of the year when frequent inspection of the filters will be required, such as spring and summer when there may be pollen, dust, dirt or debris from budding trees and bushes that can clog the filters. Also see Section 7.7 Maintenance Records in this manual.

⚠ WARNING

Danger of injury if unit starts unexpectedly. Switch power off at service disconnect. Lock-out/tag-out the disconnect.

⚠ WARNING

Danger of Electrical Shock when servicing an installed unit.

ALWAYS DISCONNECT POWER SOURCE BEFORE SERVICING! More than one disconnect switch may be required.

Proper Wiring Size Selection and Wiring Installation are the Responsibility of the Electrical Contractor.

⚠ WARNING

RISK OF INJURY OR DAMAGE.

Motor may have a manual reset thermal protector. Disconnect power before servicing or resetting motor thermal protector. Use caution, motor may be hot. Allow the motor to cool before resetting the thermal protector.

If the motor thermal protector tripped, correct the issue that caused the motor to overheat (e.g. over motor rated amperage or locked rotor).

If the motor has a manual reset thermal protector, the red thermal protector reset button is located on the motor body, on or near the lead end of the motor. If the button does not reset, the motor may still be too hot. Allow the motor to fully cool to reset the thermal protector, you should feel or hear a click when the thermal protector resets while pushing the reset button.

7.4 FILTERS

Inspection and replacement of air filters is the most frequent maintenance issue. For units that do not have filter air pressure differential sensors, filters must be visually inspected monthly, as a minimum. If a filter looks discolored or dirty, REPLACE IT! When installing new filters, DO NOT USE filter sprays. Residue from the filter spray could migrate to the enthalpic core media and damage the cores.

For units that have filter air pressure differential sensors, a dirty filter alarm will occur on the connected alarm or control device.

Filter cleanliness and replacement is the most important and frequent maintenance issue. Dirty filters will cause an immediate reduction in operating efficiency of the ERV. Normally, filters should be inspected and changed when they are dirty. Paper filters are not to be cleaned, they are to be replaced.

In general, if a filter looks dirty, replace it. The best indication of dirty filters is to check the pressure drop across the filter banks with an optional filter monitor. If it is not possible to check the pressure drop, the rule of thumb would be to change the filters every two months.

7.5 FAN MOTOR

The motor needs no lubrication. If necessary vacuum clean the blower wheels at the same time you clean the face of the energy exchange element (annually).

7.6 ENTHALPIC CORE

⚠ CAUTION
RISK OF DAMAGE TO ENTHALPIC CORES
Whenever working within the ERV cabinet, protect the enthalpic cores from accidental damage. The core media is subject to damage from dropped tools or other foreign objects

⚠ CAUTION
DO NOT WASH THE ENTHALPIC CORE.
Keep it away from water or fire to avoid damaging it. Always handle the core carefully.

7.6.1 Enthalpic Core Maintenance

The enthalpic core media is a fibrous material that must be kept clean at all times. As a minimum, cores should be cleaned once per year.

- DO NOT WASH OR ALLOW THE ENTHALPIC CORES TO GET WET.
- DO NOT EXPOSE THE ENTHALPIC CORES TO HIGH HEAT OR FLAMES.
- DO NOT DIRECT COMPRESSED AIR AT THE CORE MEDIA.
- DO NOT REMOVE THE ENTHALPIC CORES FROM THE ERV UNLESS NECESSARY.
- USE CAUTION WHEN WORKING AROUND THE ENTHALPIC CORES. DO NOT DROP TOOLS OR OTHER OBJECTS ON THE CORES, DO NOT BUMP OR TWIST THE CORES.

To access enthalpic cores for cleaning, remove the air filters.

To clean enthalpic cores, all exposed surfaces must be vacuumed with an attachment having long, soft bristles. The greatest buildup of dirt and dust will normally be on the leading 1–2 inches of the inlet side (closest to the air filters).

7.6.2 Enthalpic Core Removal

Before removing enthalpic cores, switch the main disconnect to OFF. Open the door to the Energy Recovery Module and simply pull the core straight out of its guides.

7.6.3 Enthalpic Core Replacement

Cores have foam gasketing on one end of each core. The core should be reinstalled so that the foam gasketing is toward the back of the ERV and the core label is facing toward the front. See Figure 7.8.0.

	When cores are removed from the ERV, they should be immediately protected from accidental damage, water, high heat or flames.
---	---

7.8 SERVICE PARTS

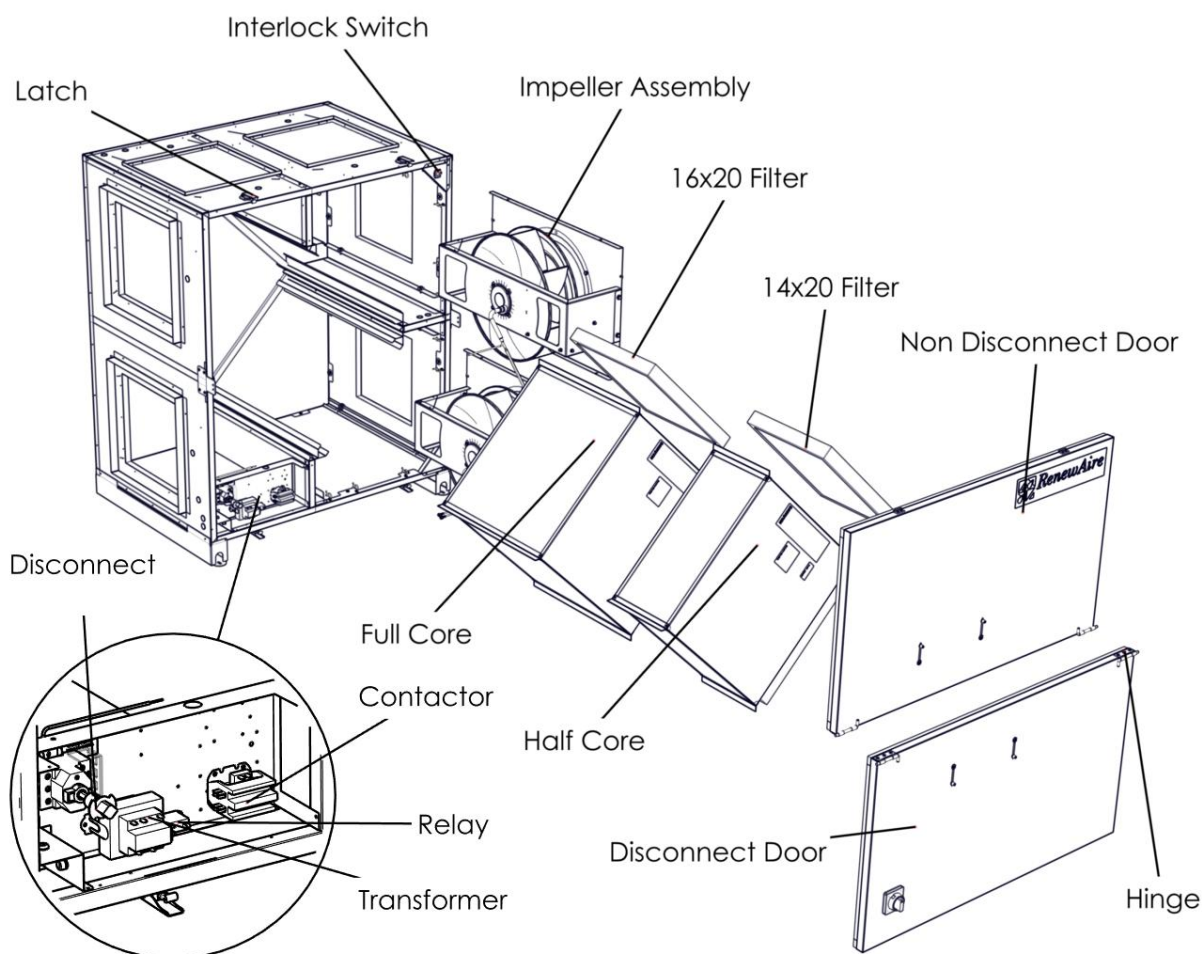

FIGURE 7.8.0 HE1.5XIN SERVICE PARTS

8.0 TROUBLESHOOTING

If problems occur with a RenewAire ERV, the primary resources for troubleshooting are the unit as-built wiring schematics and the Sequence Of Operation (SOO) for each control scheme.

9.0 FACTORY ASSISTANCE

In the unlikely event that you need assistance from the factory for a specific issue, make sure that you have the information called for in the Unit Information page in the front of this manual. The person you speak with at the factory will need that information to properly identify the unit.

To contact RenewAire Customer Service:

Call 800-627-4499

Email: RenewAireSupport@RenewAire.com



About RenewAire

For over 40 years, **RenewAire** has been a pioneer in enhancing indoor air quality (IAQ) in commercial and residential buildings of every size. This is achieved while maximizing sustainability through our fifth-generation, static-plate, enthalpic-core **Energy Recovery Ventilators (ERVs)** that optimize energy efficiency, lower capital costs via load reduction and decrease operational expenses by minimizing equipment needs, resulting in significant energy savings. Our ERVs are competitively priced, simple to install, easy to use and maintain and have a quick payback. They also enjoy the industry's best warranty with the lowest claims due to long-term reliability derived from innovative design practices, expert workmanship and **Quick Response Manufacturing (QRM)**.

As the pioneer of static-plate core technology in North America, RenewAire is the largest ERV producer in the USA. We're **committed to sustainable manufacturing** and lessening our environmental footprint, and to that end our Waunakee, WI plant is 100% powered by wind turbines. The facility is also one of the few buildings worldwide to be LEED and Green Globes certified, as well as having achieved ENERGY STAR Building status. In 2010, RenewAire joined the Soler & Palau (S&P) Ventilation Group in order to provide direct access to the latest in energy-efficient air-moving technologies. For more information, visit: renewaire.com

201 Raemisch Road | Waunakee, WI | 53597 | 800.627.4499 | RenewAire.com