

EV SERIES Premium ERV

Installation, Operation and Maintenance Manual

EV Premium S/SH
EV Premium M/MH
EV Premium L/LH
EV Premium X/XH



Model: EV Premium L, M, S shown

⚠ CAUTION

RISK OF ELECTRIC SHOCK OR EQUIPMENT DAMAGE

Whenever electrical wiring is connected, disconnected or changed, the power supply to the Energy Recovery Ventilator (ERV) and its controls must be disconnected. Lock and tag the disconnect switch or circuit breaker to prevent accidental reconnection of electric power.

⚠ CAUTION

RISK OF CONTACT WITH HIGH SPEED MOVING PARTS

This appliance has two high speed fans that can cause injury or be damaged if objects come into contact with the impellers when they are spinning. The fans may be controlled by external controllers and switch on at any time. When working in the area of the fans, electric power to the unit must be disconnected.

IMPORTANT

This ERV is intended for ducted ventilation only. Ducting at least 40 inches [1 meter] in length must be installed on all four airstreams.

⚠ CAUTION

RISK OF INJURY FROM FALLING OBJECTS

Installation of this unit requires hoisting hardware overhead and working directly beneath heavy objects during the installation process. Observe all OSHA-approved work practices. Always wear OSHA-approved Personal Protective Equipment (PPE).

IMPORTANT

This equipment is to be installed by following industry best practices and all applicable codes. Any damage to components, assemblies, subassemblies or the cabinet which is caused by improper installation practices will void the warranty.

IMPORTANT

Only persons who have been properly trained and authorized are to access the ERV electrical box and the controller. Changes to the controller are to be made only by trained and authorized personnel.

RESIDENTIAL MODEL GUIDE

ALPHANUMERIC

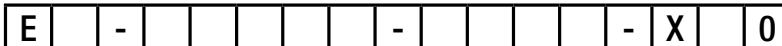

DIGIT NUMBER

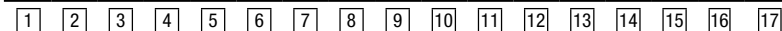

Digit 1:	Core Type
"E" = ERV	

Digit 2:	Duct Location
"E" = End/Side—4 Ducts Flexible Mounting	
"J" = End/Side—4 Ducts Flexible Mounting—Fits between Joist (24" C-C)	
"T" = Top—4 Ducts Base Mounted	

Digits 4–6:	Max CFM
"###" = Max CFM @ 0.2 ESP (Rounded)	

Digit 7:	Case Depth
"S" = > 8" & ≤ 12"	
"M" = > 12" & ≤ 18"	
"L" = > 18" & ≤ 24"	
"X" = > 24"	

Digit 8:	Cabinet Type
"F" = Foam (EPP)	
"W" = White Painted Metal	
"B" = Bare/Unpainted Metal	

Digit 10:	Power Connection
"P" = Power Cord	
"H" = Hard-Wired	

Digit 11:	Control Level/Platform
"3" = 4 Terminal Strip 24VAC-High Speed On/Off (Low On w/ Power), 1 Damper On/Off	
"5" = 16 Terminal Block 24VAC-Low/High Speed On/Off, 2 Dampers On/Off, Interlock, Remote Display, Filter/Fault/FID	

Digit 12:	Airflow Speed Capability
"4" = 2-Speed w/Constant Airflow (≤ 6 Setpoints)	
"5" = 2-Speed w/Constant Airflow (5 CFM Increments)	

Digit 13:	Additional Features
"0" = None	
"5" = OA/RA T/RH Sensors	

Digits 15–16:	Core Identification
"XB" = G5 L30	
"XC" = G5 L50	

Digit 17:	Future Use
"0" = None	

*NOTES:
Digits 3, 9, and 14 are not used in these models.

READ AND SAVE THIS MANUAL**NOTICE**

This manual has space for recording operating settings at time of unit commissioning that must be completed by the installer. See Section 4.4 of this manual.

Information that is recorded is specific to just one ERV. If additional ERVs are being documented, please make copies of these pages and identify each copy by its unit tag.

UNIT INFORMATION

Record information as shown below. In the unlikely event that factory assistance is ever required, this information will be needed.

Locate the RenewAire unit label, to be found outside of the appliance, near the terminal block. Record the model and serial numbers below.

NOTE: This information is for purposes of identifying the specific air handling appliance. Unit-specific option data can then be obtained, as needed, from the Model Number.

ERV Model: EV Premium S EV Premium SH
 EV Premium M EV Premium MH
 EV Premium L EV Premium LH
 EV Premium X EV Premium XH

Serial Number:

UNIT INFORMATION



201 Reemisch Rd Waukegan, WI 53597 (608) 627-4499
 renewairesupport@renewaire.com

ETL LISTED
 CONFORMS TO
 UL STD 1812
 CERTIFIED TO
 CAN/CSA C22.2
 No. 113
 Intertek
 4000510

Model/Modelo EVPremiumL **Part Number** 160030_000
Serial Number E2221416R

Unit Voltage 120V, 60HZ **Phase/Phase** 1 Phase/Phase, 2.5A
MCA 10 **MFS** 10
Motors / Moteurs Qty 2 : 0.11 HP & 1.22 F.L.A.
 Qty 2 : 0.11 CV de chaque & 1.22 A.P.C.

Motors Thermally Protected/ Moteurs protégés thermiquement
 For permanently Connected Units. Use Copper Conductors Only
 Pour les appareils branchés en permanence: Utiliser uniquement des conducteurs en cuivre



HVI CERTIFIED RATINGS Complete ratings at: www.hvi.org Model EVPremiumL
 Rated Air Flow@ 0.4 in wg (100 Pa) 278 cfm (131 L/s)
 Rated Air Flow@ 0.6 in wg (150 Pa) 256 cfm (121 L/s)
Energy Performance and Net Supply Air Flow
 227 cfm (107 L/s) at 32°F (0°C) Power Consumed 171 W
 ASRE: 76% SRE: 71% LMT: 0.56
 61 cfm (29 L/s) at 95°F (35°C) , Power Consumed 20 W
 ATRE: 77% TRE: 76%

⚠ WARNING ⚠ AVERTISSEMENT

Danger of electric shock. Always disconnect power source before servicing.
 Do not install in a cooking area or make line-voltage electrical power connections directly between this unit and any appliance.

Danger de chocs électriques. Toujours débrancher la source d'alimentation avant la maintenance ou les réparations. Ne pas installer dans une zone de cuisson ou brancher directement la demande de courant principale de cet appareil sur n'importe quel autre appareil.

Not for Outdoor Use/ N'est pas fait pour une utilisation extérieure.

Label PN: 160079_002

UNIT LABEL (TYPICAL)

FOR THE INSTALLER	6	FOR THE HOMEOWNER	20
1.0 OVERVIEW	6	5.0 ERV INTRODUCTION AND COMPONENTS	20
1.1 INTRODUCTION.....	6	5.1 ERV COMPONENTS.....	20
1.2 UNIT FEATURES.....	6	5.1.1 Enthalpic Core.....	20
2.0 INSTALLATION	8	5.1.2 Filters.....	20
2.1 MOUNTING THE UNIT.....	8	5.1.3 Fans.....	20
2.2 INSTALLING DUCTWORK.....	10	5.1.4 Controls.....	21
3.0 ELECTRICAL HOOK-UP AND CONTROLS	12	5.2 CONTROL ACCESSORIES.....	22
3.0.1 EV Premium S, M, L, X.....	12	5.2.1 Percentage Timer (PTL) and Furnace Interlock (FM).....	22
3.0.2 EV Premium SH, MH, LH, XH.....	12	5.2.2 Push Button Boost Timer (PBT) and Push Button (PBL).....	22
3.1 LOW-VOLTAGE WIRING DIAGRAMS	12	5.2.3 Digital Time Clock (TC7D).....	23
3.1.1 Single Speed Mode Continuous.....	12	5.2.4 CO2 Sensor, Occupancy Sensor and IAQ Sensor.....	23
3.1.2 Low Speed Continuous/High Speed Switched.....	12	6.0 MAINTENANCE	24
3.1.3 Single Speed Mode Switched (Intermittent).....	12	6.1 MAINTENANCE AFTER 30 DAYS OPERATION.....	24
3.2 DAMPER OPERATION	13	6.2 RECALIBRATION OF AIRFLOWS.....	24
3.2.1 Damper installation for Continuous ERV Operation.....	13	6.3 DOOR REMOVAL.....	24
3.2.2 Damper Installation for Intermittent ERV Operation.....	13	6.4 SERVICE PARTS.....	25
3.3 WIRING SCHEMATICS	14	7.0 TROUBLESHOOTING	26
4.0 START-UP AND COMMISSIONING	16	7.1 INDICATION OF PROBLEM.....	26
4.1 FAN OPERATION.....	16	7.2 ERV HAS AIRFLOW BUT IS MAKING NOISE.....	26
4.2 SELECTING AIRFLOW SETTINGS.....	16	7.4 INADEQUATE OR REDUCED AIRFLOW FROM THE ERV.....	27
4.3 BALANCING AIRFLOWS.....	16	8.0 FACTORY ASSISTANCE	27
4.4 CONVERSION OF PRESSURE DROP TO AIRFLOW.....	18		
4.4.1 Conversion of Pressure Drop to Airflow.....	18		
4.4.2 Continuous Mode (low speed).....	19		
4.4.3 Boost Mode (high speed).....	19		

TABLE OF ILLUSTRATIONS

Figure 1.1.0 Airstream Illustration	6
Figure 1.2.0 EV Premium Cutaway View	6
Figure 1.2.1 Controls Terminal Strip	7
Figure 2.1.0 Unit Mounting Steps	8
Figure 2.1.1 Unit Mounting Steps continued.....	9
Figure 2.2.0 Separate Return Air Pick-up—Supply Air to Furnace Return Air Trunk	11
Figure 2.2.1 Separate Return Air and Supply Air	11
Figure 2.2.2 Furnace Return Air Back into Return Air	11
Figure 2.2.3 Furnace Return Air Back into Supply Air.....	11
Figure 3.1.0 Low-Voltage Wiring Diagram 1	12
Figure 3.2.0 Damper Hook-up for Continuous ERV Operation	13
Figure 3.2.1 Damper Hook-up for Intermittent ERV Operation.....	13
Figure 3.3.0 EV Premium Wiring Schematic.....	14
Figure 3.3.1 EV Premium Hard-wired Wiring Schematic	15
Figure 4.1.0 Potentiometer Dials	16
Figure 4.3.0 Pressure Port Locations	17
Figure 4.3.1 Fan Speed Control Potentiometers	17
Figure 4.4.0 Pressure Drop to Airflow Conversions	18
Figure 5.0.0 EV Premium Airflow Pattern.....	20
Figure 5.1.0 ERV Components	21
Figure 5.2.0 PTL and FM Control	22
Figure 5.2.1 PBT and PBL Control	23
Figure 5.2.2 TC7D Control (Wall Mount)	23
Figure 5.2.3 CO ₂ , IAQ, and Motion Occupancy Sensors	23
Figure 6.4.0 EV Premium Service Parts	25

 **NOTE:** Sections 1–4 of this manual contain information for the installer and sections 5–8 contain information for the Homeowner or end user.

FOR THE INSTALLER

1.0 OVERVIEW

1.1 INTRODUCTION

RenewAire’s EV Premium units are multi-speed air-to-air energy recovery ventilators. Each unit contains a static-plate, cross-flow core that transfers both sensible and latent energy between the polluted indoor airstream being exhausted and the incoming fresh outdoor airstream being supplied to the dwelling. Airstreams do not mix, and pollutants are not transferred across partition plates. In the winter, that means that the cold, dry outside air is preheated and humidified by the outgoing warm interior air. And in the summer, the warm, humid outside air is pre-cooled and dehumidified by the outgoing air-conditioned interior air.

NOTE: This unit is an energy recovery ventilator, or ERV. It is commonly referred to throughout this manual as an ERV.

NOTE: Sensible energy is often referred to as “heat energy.”

NOTE: Latent energy is often referred to as “moisture energy.”

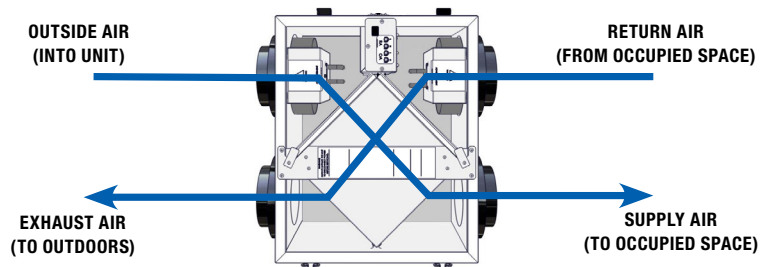

FIGURE 1.1.0 AIRSTREAM ILLUSTRATION

1.2 UNIT FEATURES

EV Premium ERVs are designed for residential applications and have multiple installation options. The units feature high efficiency, speed controllable EC motors and four speed control dials to allow independent adjustment of the fresh and exhaust airstreams both for continuous operation and boost mode. EV Premium ERVs come factory equipped with MERV 8 filters, with MERV 13 accessories available.

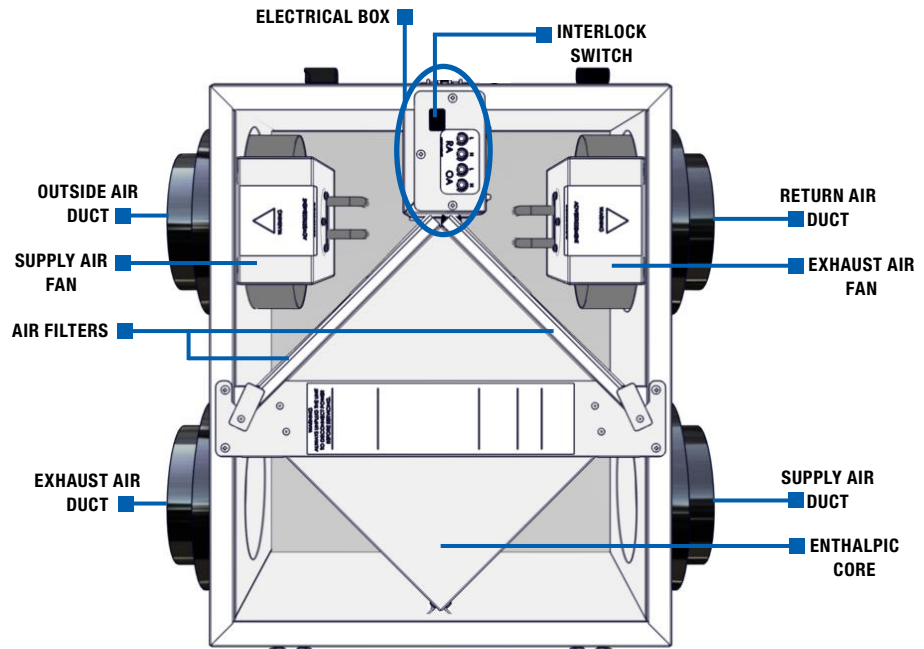

FIGURE 1.2.0 EV PREMIUM CUTAWAY VIEW

The ERV also contains a low voltage terminal strip on the end of the unit, near the line cord. The terminal strip allows for accessory hookups to trigger boost mode operation, and a terminal to tie in damper operation when the unit is running. Refer to section 3.0 for the various controls strategies that can be used on EV Premium products.

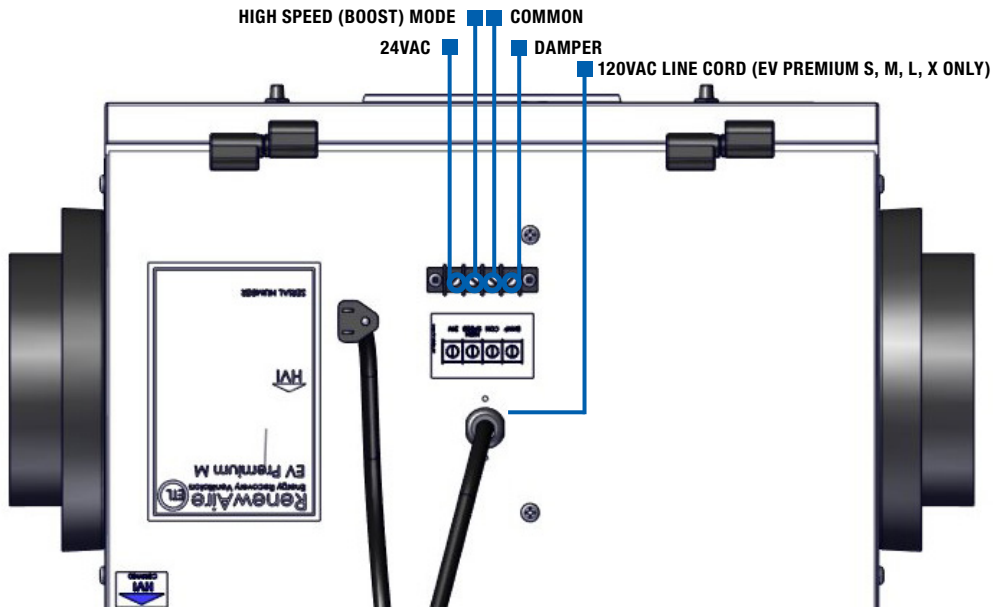



FIGURE 1.2.1 CONTROLS TERMINAL STRIP

2.0 INSTALLATION

2.1 MOUNTING THE UNIT

EV Premium ERVs may be installed in any position providing sufficient clearance for controls and door access. The preferred position is horizontal so that the hinged access door can swing down to allow for easiest filter changes and cleaning of the enthalpic core.

To mount the unit to a concrete foundation or stud wall, mount hanging bracket to the wall with appropriate concrete anchors. Use pre-cut foam tape from small parts bag. Remove backing and apply two pieces of foam tape equally spaced along the unit's mounting flange to be held by the hanging bracket. Apply the other two pieces of foam over two holes that will be used for fastening, on the other flange. The tape should be applied in a "U" shape to cushion both the front and back of the integral flanges.

 **NOTE:** The door is equipped with slide-off hinges. For the homeowner's convenience, it is helpful to orient the unit so that the door is easily removed when unlatched.

 **NOTE:** Do not over-tighten the screws. Compression of the gasket may result in vibration transfer.

 **NOTE:** Wall brackets must be supported by two wall studs. If the desired location of the EV Premium does not permit support by two wall studs, the EV Premium must be mounted on a user-supplied 3/4" thick plywood panel that is anchored on two wall studs.

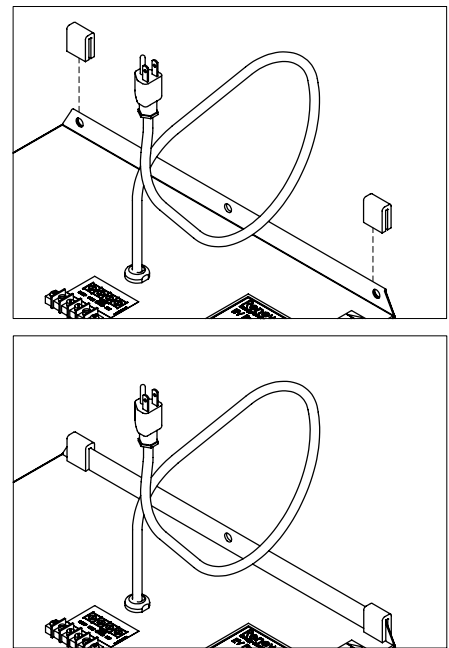
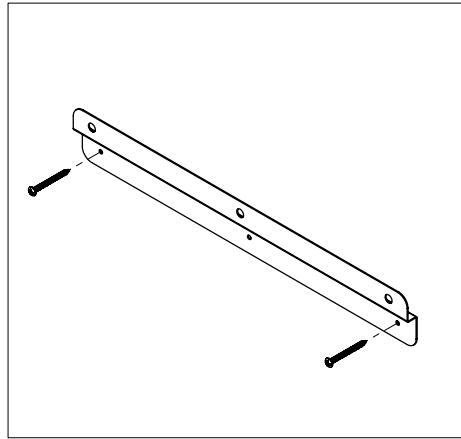

FIGURE 2.1.0 UNIT MOUNTING STEPS

Lift unit and slide unit flange into the hanging bracket. Using metal flat washers, fasten flange opposite hanging bracket to structure. Safety screws should similarly be installed passing through the hanging bracket and flange. Make sure the screws, which must be supplied by the installer, are properly selected for the loads and substrate involved, 2" x #10 pan head screws are recommended.

⚠ CAUTION

Risk of injury when lifting unit and installing it overhead.

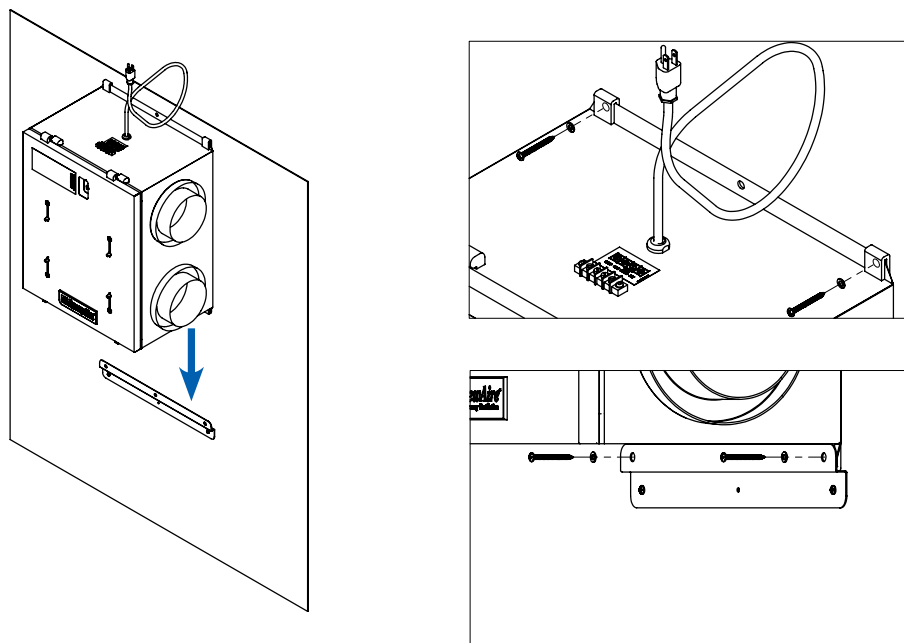

FIGURE 2.1.1 UNIT MOUNTING STEPS CONTINUED

The unit may also be screwed directly to joists or trusses using the hanging bracket and integral flange. Mount as described for mounting to concrete foundation wall.

When installing the unit be sure to allow sufficient space to open the door latches and for the door to be able to swing open at least 90°. Also ensure there is space to access the terminal block at the end of the unit.

2.2 INSTALLING DUCTWORK

IMPORTANT

It is important to understand and use the equipment airstream terminology as it is used in this manual. The airstreams are defined as:

- Outside Air (OA): Air taken from the external atmosphere and, therefore, not previously circulated through the system.
- Supply Air (SA): Air that is downstream of the enthalpic core and is either supplied to the occupied space or to an additional conditioner.
- Conditioned Air (CA): Air that is supplied to an occupied space.
- Return Air (RA): Air that is returned to a heating or cooling appliance from a conditioned space.
- Exhaust Air (EA): Air that is removed from a heating or cooling appliance and discharged.

EV Premium units are supplied with a set of 4 duct connectors that must be field-installed. The EV Premium S/SH, M/MH and L/LH connectors can be used with 6" or 8" round ducts. The EV Premium X/XH connectors can be used with 8" flexible or 8" oval rigid duct. It is preferable to keep duct runs short and straight to maximize performance.

For all installations, SMACNA guidelines for duct installation should be followed. The most commonly used ducting is 6" diameter flexible due to ease of installation, sound attenuation, and cost, however, rigid ducting is preferred because there is less resistance to airflow, resulting in less power consumption to deliver the same amount of air.

A total of four duct runs will generally be used:

- Outdoor Air Intake (OA): This duct will provide clean outdoor air to the unit, and is normally capped by an air inlet cap mounted on the exterior side wall of a residence and equipped with a bird screen.

Wall intakes must be located at least 10' from any appliance vent or any vent opening from a plumbing drainage system and 10' from any exhaust fan discharge outlet unless that outlet is 3' or more above the intake location (IRC 2006, Section M1602.2). If a combined exhaust/intake termination is used (with non-kitchen exhaust only) then no minimum separation is required when the exhaust air concentration within the intake airflow does not exceed 10% as established by the manufacturer. (ASHRAE 62.2-2019, Section 6.68).
- Fresh Air Supply (SA): This duct will deliver fresh, conditioned air from the ERV to a desired location in the residence. This duct run may end in a floor or wall grate with an area of at least 28 square inches. Alternatively, the supply air duct may be connected directly into the return air duct or the supply air duct for the main heating and cooling system. When connecting to the main return air duct, it must be at least 3' from the return plenum to minimize suction from the furnace blower.
- Indoor Air Return (RA): This duct will collect indoor Air from return grilles and run it through the ERV for energy recovery before being exhausted to the outdoors.
- Outdoor Air Exhaust (EA): This duct exhausts stale indoor air to the outdoors after being run through the energy recovery core. This duct will normally end at an exhaust cap located on an exterior wall of a residence.
- Airstreams may be swapped during installation. This is an acceptable installation that does not effect unit performance or warranty. See Figure 5.0.0 for more information.



NOTE: Ducts inside a building that are connected to the outside must be insulated with a sealed vapor barrier on both the inside and the outside of the insulation. Insulation must have an R-value of at least R-6, but R-8 is recommended.



NOTE: The installer should note if airstreams are swapped.

Figures 2.2.0-2.2.3 show a few common installation methods.

If the unit is located in a conditioned space, only the OA and EA ducts need to be insulated. For unconditioned space installations such as an attic or crawl space all four ducts must be insulated and have the application evaluated by a HVAC design professional or RenewAire.

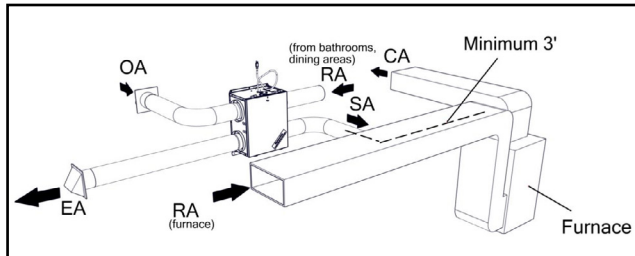

FIGURE 2.2.0 SEPARATE RETURN AIR PICK-UP—SUPPLY AIR TO FURNACE RETURN AIR TRUNK

NOTE: ERV blower may be operated separate from furnace blower.

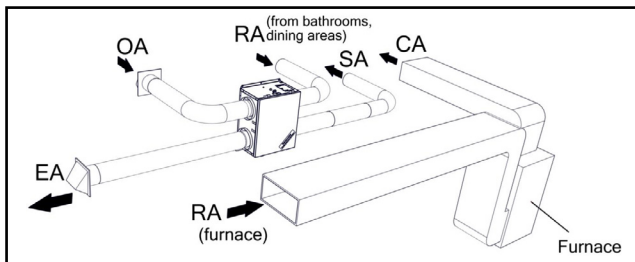

FIGURE 2.2.1 SEPARATE RETURN AIR AND SUPPLY AIR

NOTE: ERV blower may be operated independently from furnace blower. Use caution to introduce SA at low velocity and where good mixing will occur to minimize discomfort from drafts

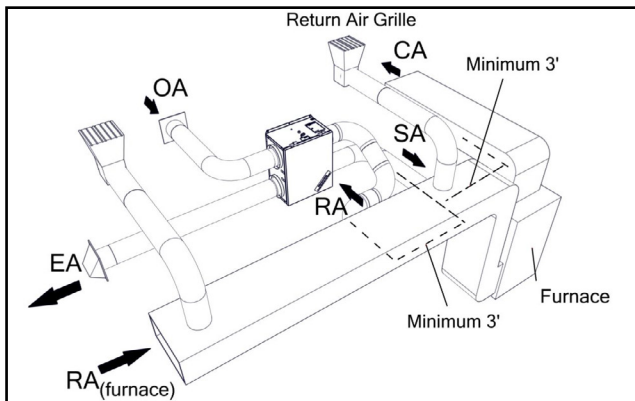

FIGURE 2.2.2 FURNACE RETURN AIR BACK INTO RETURN AIR

NOTE: For the setup in Figure 2.2.2, the furnace blower must be operated any time the ERV is operated. Use furnace fan “on” continuous low speed or optional FM control to cycle furnace fan on ERV.

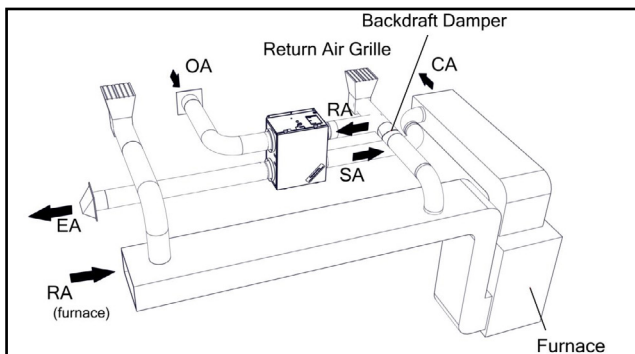

FIGURE 2.2.3 FURNACE RETURN AIR BACK INTO SUPPLY AIR

NOTE: ERV blower may be operated separate from furnace blower.

3.0 ELECTRICAL HOOK-UP AND CONTROLS

3.0.1 EV Premium S, M, L, X

Power requirements for EV Premium S, M, L: 120VAC, 3.0 amps

Power requirements for EV Premium X: 120VAC, 5.5 amps

The EV Premium S, M, and L have an integral 34" long power supply cord. The installer must provide a standard, grounded 120VAC outlet in the proximity of the ERV. Check all local codes.

3.0.2 EV Premium SH, MH, LH, XH

Power requirements for EV Premium S, M, L: 120VAC, 3.0 amps

Power requirements for EV Premium X: 120VAC, 5.5 amps

The EV Premium SH, MH, LH, and XH are to be hard-wired by the installer. Check all local codes before wiring. A disconnect switch on the AC supply line may be required.

3.1 LOW-VOLTAGE WIRING DIAGRAMS

3.1.1 Single Speed Mode Continuous

When plugged in, the unit will run constantly at Low Speed. If the unit is to operate constantly at a single airflow, adjust the OA and RA low speed potentiometers to the desired airflow as described in section 4.3. The high speed potentiometers are not needed for this application.

3.1.2 Low Speed Continuous/High Speed Switched

The ERV can be installed to run constantly at Low Speed (Continuous mode) and then switch periodically to Boost Mode in response to a controller. To achieve this, the external controller, such as a PBT control or an occupancy sensor that is to trigger Boost Mode (High Speed), is connected to the 24VAC terminal and to the High Speed terminal.

NOTE: Do not connect either wire from PBT to the COM terminal on the unit.

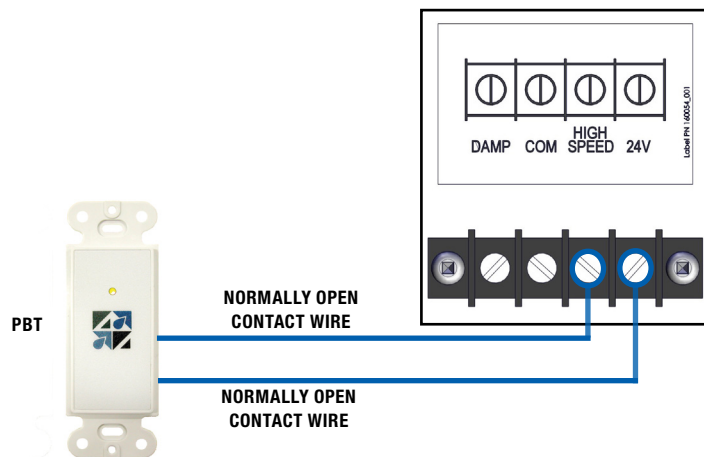

FIGURE 3.1.0 LOW-VOLTAGE WIRING DIAGRAM 1

3.1.3 Single Speed Mode Switched (Intermittent)

If the unit is to operate intermittently without a continuous flow, an external controller will need to be used as in figure 3.1.0. To achieve this operation, turn the low speed potentiometers fully counterclockwise and connect the desired controlling accessory to the 24V and High Speed terminals on the unit. Set the high speed potentiometers to the desired flow rate for the intermittent operation. When the unit is plugged in, there will be no airflow until the control accessory signals the unit to operate in High Speed mode.

3.2 DAMPER OPERATION

When the ERV is connected to a ducted return of the HVAC system, outdoor air may be pulled through the ERV via the HVAC fan. This can be prevented by installation of a damper installed at the fresh air outlet of the ERV. RenewAire's MD-Series 24-volt dampers can be wired to an EV Premium unit for this purpose. For more detailed information on installation, please refer to the MD series damper manual.

3.2.1 Damper installation for Continuous ERV Operation

If the ERV is set up to provide continuous airflow, an MD series damper can be wired to the 24VAC and COM terminals on the unit terminal block. The damper will open whenever the unit has 120VAC power and close when power is lost.

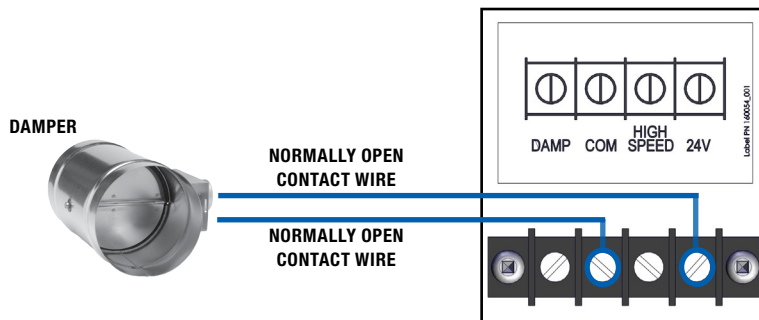

FIGURE 3.2.0 DAMPER HOOK-UP FOR CONTINUOUS ERV OPERATION

3.2.2 Damper Installation for Intermittent ERV Operation

If the ERV is intended to operate intermittently as described in section 3.1.3, turn the low speed potentiometers fully counterclockwise to off and wire a control to the 24V and High speed terminals. Wire the damper to the DAMP and COM terminals. The unit will remain off, and the damper closed until the control activates the high speed terminal. When the High Speed terminal is activated, the unit fans will operate at the flow corresponding to the High Speed potentiometers and the damper will open.

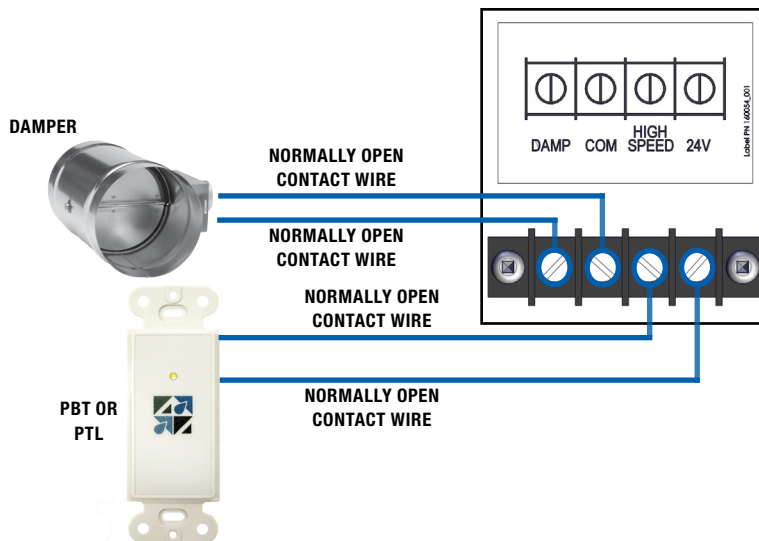

FIGURE 3.2.1 DAMPER HOOK-UP FOR INTERMITTENT ERV OPERATION

3.3 WIRING SCHEMATICS

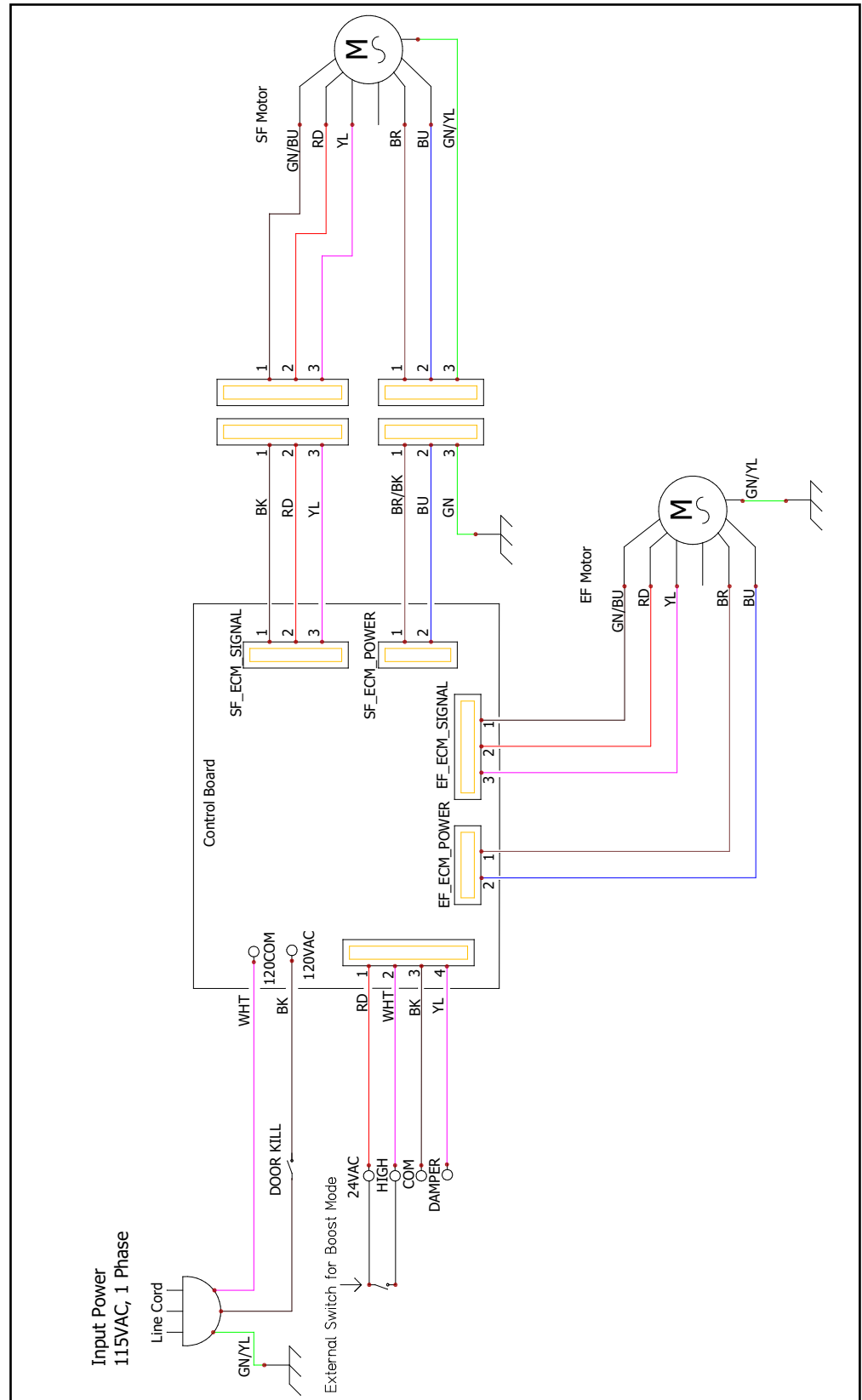

FIGURE 3.3.0 EV PREMIUM WIRING SCHEMATIC

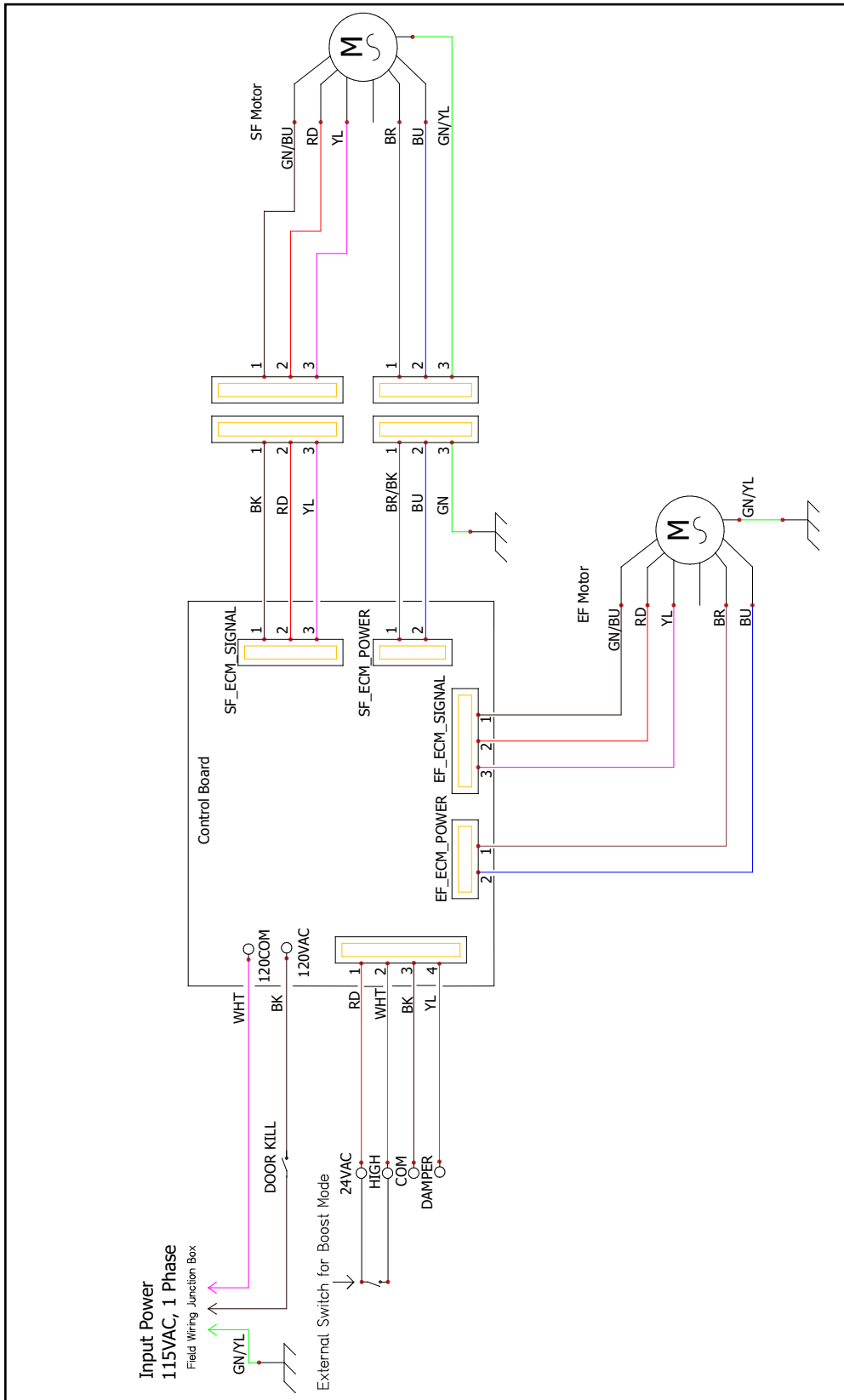

FIGURE 3.3.1 EV PREMIUM HARD-WIRED WIRING SCHEMATIC

4.0 START-UP AND COMMISSIONING

4.1 FAN OPERATION

EV Premium units have two operating modes: Continuous and Boost. Continuous mode should be set to provide the minimum ventilation requirement. Boost mode can be used to supply and exhaust a greater volume of air.

The two operating modes are selectable and controlled independently so that different controlling methods can be used to switch back and forth. Example: an IAQ sensor could be used to switch the unit to Boost mode as described in Section 3.

The unit has four dial potentiometers accessible through the door. The two marked "OA" control the Outdoor/Supply fan and the two marked "RA" control the Return/Exhaust fan. The two marked "L" control the low/continuous speed settings and the two marked "H" control the high/boost speed settings.

If the dials are rotated fully counter-clockwise, the fans will turn off. If the dials are rotated fully clockwise, the fans will operate at maximum speed.

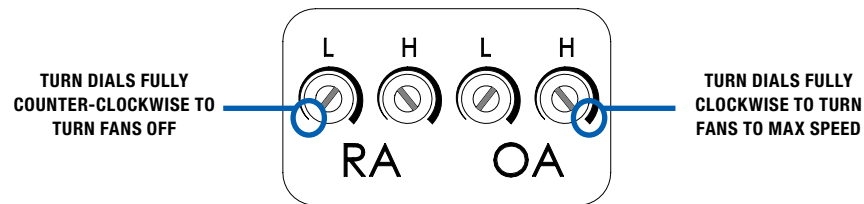

FIGURE 4.1.0 POTENTIOMETER DIALS

4.2 SELECTING AIRFLOW SETTINGS

For assistance in determining correct airflow settings, go to <https://renewaire.com/home-ventilation-guide/>. This site will provide a basic low-speed (Continuous) air volume for a residence based on factors such as square footage and the number of bedrooms that are to be entered by the user. The resulting airflow volume is to be used as a guide and modified as desired.



NOTE: Airflow volumes can be changed at any time by the user as experience dictates. Whenever changing airflow volumes for either Continuous (low speed) or Boost (high speed) modes, the fans should again be balanced.

The need for boost mode varies by situation. For example, boost mode could be tied to bathroom and shower usage. Alternatively, boost mode might be set for specific times of the day when more people will be in the space being ventilated. In all cases, an HVAC professional should be consulted to determine how to best set the airflow volumes to provide maximum benefit to the inhabitants.

Airflow volumes are set by taking pressure readings at the pressure ports in the unit door and then adjusting the potentiometers, first the two low speed ones, then the two high speed ones. Normally, the low-speed OA and RA potentiometers are set and then the readings are compared to the chart in Section 4.4 of this manual. Measuring the pressure drop across the core for each airstream is used to determine the airflow volume.

4.3 BALANCING AIRFLOWS

EV Premium ERVs provide the ability to deliver and exhaust completely balanced airflows, or to modify them as desired. While balanced airflow is preferred, many owners will prefer to have a slight imbalance, providing a slight excess of Outdoor Air to reduce air infiltration into a home. Some homes may require an imbalance because a furnace or water heater is not direct-vented. Again, an HVAC professional will be able to advise balance settings that will best address the circumstances in each home.

Balancing an airflow is done by setting the Outdoor Air fan speed and then adjusting the Return Air fan speed to eject the same or somewhat less air to the outdoors.

Equipment required for testing airflows:

- A magnehelic gauge (or manometer) or other device capable of measuring 0–1.0 inches water gauge of differential pressure.
- 2 pieces of natural rubber latex tubing, 1/8" I.D., 1/16" wall thickness works best.

Manometers are relatively inexpensive devices that are readily available from online retailers; accuracy within the range of 0–1.0 in. w.g. is the critical measure. Water manometers generally have graduations of 0.1" that are difficult to accurately determine. For all manometers, there are two plastic tubes that connect at the manometer and then the other ends go to pressure ports on the ERV.

Individual differential static pressures (DP) are measured across the core and filters, using the installed pressure ports located on the removable door.

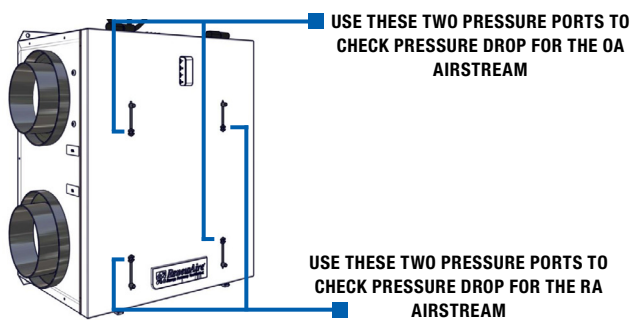

FIGURE 4.3.0 PRESSURE PORT LOCATIONS

- Verify the unit has clean filters in place.
- Open the pressure port caps for the OA airstream and then insert the tubing into the openings about 1".
- Take a differential pressure reading for the OA airstream by installing the “high” pressure side (+) of the measuring device to the OA port and the “low” pressure side (-) to the SA port. Compare the pressure drop to the chart in section 4.4.1 to obtain the CFM. Adjust the fan speed potentiometer (See figure 4.3.1) to obtain the desired CFM. Enter the CFM information in the box in section 4.4.
- Take a differential pressure reading for the RA airstream by installing the “high” pressure side (+) of the measuring device to the RA port and the “low” pressure side (-) to the EA port. Compare the pressure drop to the chart in section 4.4.1 to obtain the CFM. Adjust the fan speed potentiometer (See figure 4.3.1) to obtain the desired CFM. Enter the CFM information in the box in section 4.4.
- Install a jumper on the low-voltage terminal to force the unit into Boost (high speed) mode. See the wiring diagram in Section 3.3.
- Repeat the process for both airstreams to set both the CFM and balance. Enter the information in the boxes in Section 4.4.
- After adjusting the potentiometers, take additional readings as needed to verify that fan speed settings are correct. See Figure 4.3.1.



FIGURE 4.3.1 FAN SPEED CONTROL POTENTIOMETERS

4.4 CONVERSION OF PRESSURE DROP TO AIRFLOW

4.4.1 Conversion of Pressure Drop to Airflow

See the tables below.

(Units equipped with clean MERV 8 filters.)

To determine the airflow in CFM, obtain the manometer readings shown above and calculate the differences between them. Then apply the following formula to convert the readings to CFM:

EV Premium S/SH: [Airflow in CFM] = 183 x [Pressure Drop in inches w.g.]

EV Premium M/MH: [Airflow in CFM] = 283 x [Pressure Drop in inches w.g.]

EV Premium L/LH: [Airflow in CFM] = 593 x [Pressure Drop in inches w.g.]

EV Premium X/XH: [Airflow in CFM] = 593 x [Pressure Drop in inches w.g.]

EXAMPLE: 1 In. w.g. of pressure drop corresponds to 283 CFM, 0.5 In. w.g. corresponds to 141.5 CFM, and so on for the EV Premium M.

(Units equipped with a MERV 13 filter in the OA airstream. Formulas below are for OA airstream only.)

EV Premium S/SH: [Airflow in CFM] = 154 x [Core Pressure Drop in inches w.g.]

EV Premium M/MH: [Airflow in CFM] = 235 x [Core Pressure Drop in inches w.g.]

EV Premium L/LH: [Airflow in CFM] = 487 x [Core Pressure Drop in inches w.g.]

EV Premium X/XH: [Airflow in CFM] = 487 x [Core Pressure Drop in inches w.g.]

EXAMPLE: 1 In. w.g. of pressure drop across the core corresponds to 235 CFM, 0.5 In. w.g. corresponds to 117.5 CFM, and so on for the EV Premium M.

EV PREMIUM S/SH		
Pressure Drop (In. W.G.)	Airflow with MERV 8 Filters (CFM)	Airflow with MERV 13 Filters (CFM)
0.1	18	15
0.2	37	31
0.3	55	46
0.4	73	62
0.5	92	77
0.6	110	92
0.7	128	108

EV PREMIUM M/MH		
Pressure Drop (In. W.G.)	Airflow with MERV 8 Filters (CFM)	Airflow with MERV 13 Filters (CFM)
0.1	28	24
0.2	57	47
0.3	85	71
0.4	113	94
0.5	142	118
0.6	170	141
0.7	198	165

EV PREMIUM L/LH		
Pressure Drop (In. W.G.)	Airflow with MERV 8 Filters (CFM)	Airflow with MERV 13 Filters (CFM)
0.1	59	49
0.2	119	97
0.3	178	146
0.4	237	195

EV PREMIUM X/XH		
Pressure Drop (In. W.G.)	Airflow with MERV 8 Filters (CFM)	Airflow with MERV 13 Filters (CFM)
0.1	59	49
0.2	119	97
0.3	178	146
0.4	237	195
0.5	297	244

FIGURE 4.4.0 PRESSURE DROP TO AIRFLOW CONVERSIONS

4.4.2 Continuous Mode (low speed)

Outdoor Airflow: CFM

Return Airflow: CFM

4.4.3 Boost Mode (high speed)

Outdoor Airflow: CFM

Return Airflow: CFM

FOR THE HOMEOWNER

5.0 ERV INTRODUCTION AND COMPONENTS

The purpose of your EV Premium ERV is to bring fresh air into your home, and exhaust stale room air improving your indoor air quality. While bringing fresh air into your home, the ERV uses the stale exhaust air to transfer heat and moisture without mixing, reducing the demand on the rest of your HVAC system.

 **NOTE:** Airstreams may be swapped during installation. This is an acceptable installation that does not effect unit performance or warranty. If airstreams are swapped, the OA and RA arrows will switch positions in Figure 5.0.0, as well as the EA and SA arrows. The installer should note if airstreams are swapped.

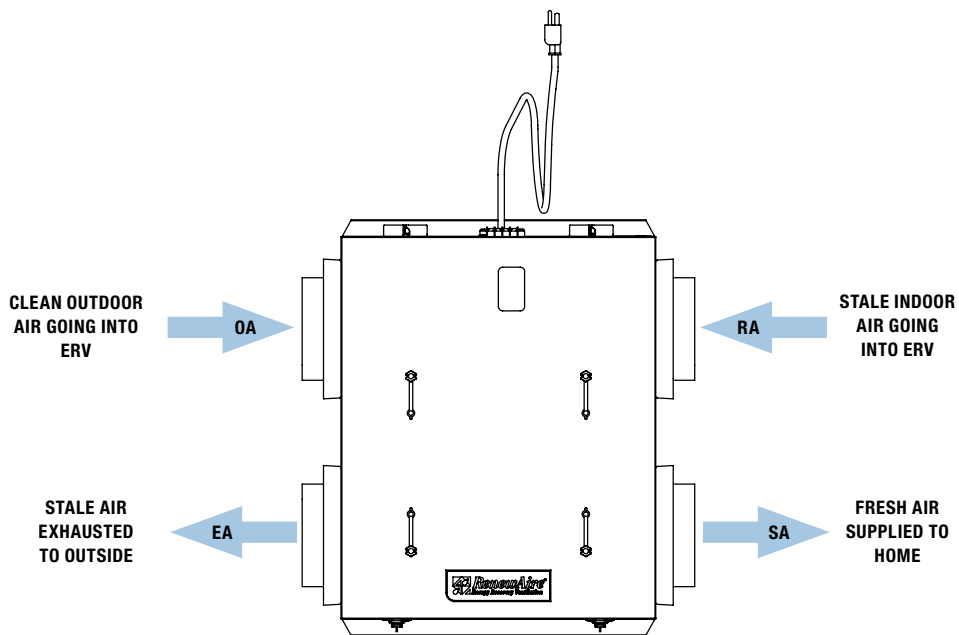

FIGURE 5.0.0 EV PREMIUM AIRFLOW PATTERN

5.1 ERV COMPONENTS

The main components in your EV Premium ERV are the static plate core, two filters, two motorized fans and the controls system.

5.1.1 Enthalpic Core

As mentioned above, each EV Premium ERV Each unit contains a static-plate, cross-flow core that transfers both sensible and latent energy between the polluted indoor airstream being exhausted and the incoming fresh outdoor airstream being supplied to the dwelling. Airstreams do not mix, and pollutants are not transferred across partition plates.

5.1.2 Filters

Each unit is equipped at the factory with mesh-type anti-microbial MERV 8 filters on both the OA and RA sides of the core. If desired, the mesh-type OA filter can be replaced with an optional MERV 13 pleated paper filter accessory, which will ship loose.

5.1.3 Fans

EV Premium units have two advanced, high efficiency electronically commutated (EC) 120VAC variable speed fans. One fan is used for intake air (Outdoor Air/Supply Air) and the other fan is for the exhaust airstream (Return Air/Exhaust Air). The speed of each fan is controlled independently by a 0–10VDC signal from the controller.

5.1.4 Controls

The controller provides the signal to the EC motors using integral potentiometers. Incoming line voltage powers both fans and also a step-down Class II transformer which provides 24VAC to the externally-mounted low-voltage terminal strips. The controller has four potentiometers that are adjusted by the user to establish fan speeds for each operation mode.

Each unit has one terminal strip mounted on the end of the unit. The terminal strip is a 24VAC power supply terminal. The unit control board provides up to 12VA (approximately 0.5A) which can be used to power the various optional control accessories.

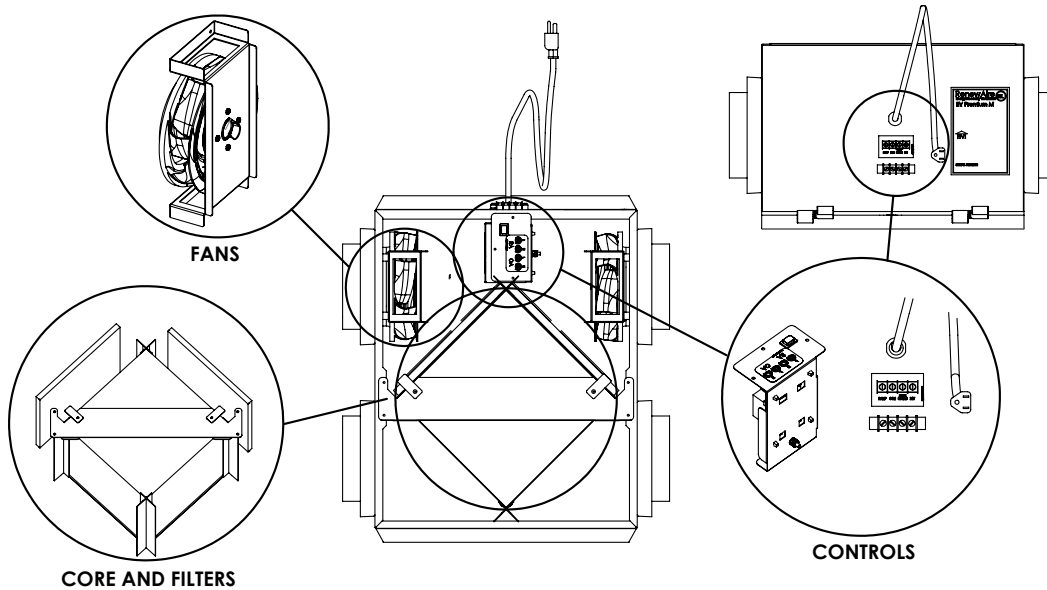



FIGURE 5.1.0 ERV COMPONENTS

5.2 CONTROL ACCESSORIES

If your EV Premium ERV is set to operate intermittently at a single speed, or employ Boost mode, you will have a control connected to the low voltage terminal block on the side of the unit. Full information for each control, including wiring diagrams can be found on www.renewaire.com.

 **NOTE:** The unit can only accept 1 master controller (PTL, FM, or PBT).

5.2.1 Percentage Timer (PTL) and Furnace Interlock (FM)

The Percentage Timer Control with indicator lights (PTL) will operate your ERV an adjustable amount of time each hour. When the “Runtime %” light is on, the PTL control is telling your ERV to operate. Additionally, the PTL can be set to turn your ERV off or to operate constantly. Discuss any questions with your HVAC professional or contact RenewAire directly. For EV Premium units, the PTL can be used for intermittent flow operation, or to trigger Boost mode.

The Percentage Timer Control with indicator lights and furnace interlock (FM) operates the same as the PTL control, except the FM ties into your furnace to turn your ERV and your furnace/air-conditioning blower on together.

Constant Operation: Press the RenewAire logo until the light next to “100” is lit.

Operation Each Hour: Run time of your ERV (or Boost Mode) can be adjusted from 10%, or 6 minutes each hour, up to 100% operation in 10% increments. Simply press the RenewAire logo until the light next to the desired percentage is lit. You can increase or decrease the run time based upon daily, weekly or monthly variations in occupancy levels, indoor odors, cold weather winter humidity, or other indoor air quality concerns as needed.

For no regular operation: Press the logo until all lights are off. The control is off.

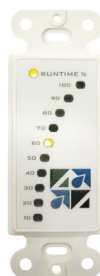

FIGURE 5.2.0 PTL AND FM CONTROL

5.2.2 Push Button Boost Timer (PBT) and Push Button (PBL)

The Push Button Boost Timer (PBT) point-of-use control with indicator light will operate your ERV for either 20, 40, or 60 minutes based upon how many times the logo button has been pushed. The indicator light on the front of the PBT control is on whenever the PBT is operating the ERV. A PBT control is most commonly used to trigger Boost mode on your ERV for activities like cooking and showering.

20-40-60 Minute Ventilation Control:

Press the logo and your ventilator will run for 20 minutes. Press again and the unit will run 40 minutes. A third press provides for 60 minutes of operation.

You can cancel a cycle at anytime. Just press the logo for a fourth time.

You can start another cycle by pressing the logo.

The Push Button point-of-use control with indicator Light (PBL) operates the same as the Push Button Boost Timer (PBT). The difference between the PBL and PBT is that the PBL is a secondary control and must be used in conjunction with a PBT or PTL primary control. Up to six PBL controls have be used with a PBT or PTL primary control.



FIGURE 5.2.1 PBT AND PBL CONTROL

5.2.3 Digital Time Clock (TC7D)

The Digital Time Clock (TC7D-W and TC7D-E) can be used to program scheduled operation for the ERV. The Time Clock supports schedules for individual days of the week, weekdays, weekends, and several other pre-program combinations of days. The time clock has an “ON,” “OFF” and “AUTO” mode. Auto mode allows the ERV to operate on the pre-programmed schedule, but On and Off modes can be used to override the schedule and force the ERV into operation or shutting off. For more information on the Time Clock, see the TC7D Series manual on RenewAire’s website.



FIGURE 5.2.2 TC7D CONTROL (WALL MOUNT)

5.2.4 CO2 Sensor, Occupancy Sensor and IAQ Sensor

EV Premium unit operation can also be controlled by a variety of sensors. The CO2 sensor can be set to operate the unit, or trigger Boost Mode, once the space exceeds the CO2 limit set by the sensor. Once the measured concentration has reduced below the threshold, the unit will return to normal operation, or turn off, depending on the installation. The IAQ sensor operates similarly to the CO2 sensor, except it will measure a variety of VOCs such as smoke, cooking odors, bio-effluence, outdoor pollutants, and from human activities.

The Occupancy sensor features a passive infrared sensor that will trigger the unit when the space is occupied and return to normal operation when the space is unoccupied.

For more information on these three sensors, refer to the individual control instruction manuals found on RenewAire’s website.



FIGURE 5.2.3 CO2, IAQ, AND MOTION OCCUPANCY SENSORS

IMPORTANT

This unit is only to be used after completion of building construction. It is not to be used during construction.

6.0 MAINTENANCE

The primary maintenance requirement is filter replacement. Filters are not to be cleaned, they must be replaced. The standard filter as shipped from the factory is a mesh-type, anti-microbial MERV 8. These standard filters are NOT to be sprayed with filter treatments or dust adhesives. The standard mesh-type OA MERV 8 filters may be replaced with pleated paper MERV 13 filters post-construction, if desired. Both filters should be replaced every three months, or more frequently, if needed, based on the cleanliness of the OA and RA air entering the unit.

The enthalpic core should be vacuumed annually. Remove the unit cover and then remove the filters for access to the core. Use a soft-bristled nozzle on a good vacuum and carefully vacuum the inlet faces of the core.

- Do not wash or allow the enthalpic cores to get wet.
- Do not expose the enthalpic cores to high heat or flames.
- Do not direct compressed air at the core media.
- Do not remove the enthalpic cores from the ERV unless necessary.
- Use caution when working around the enthalpic cores. Do not drop tools or other objects on the cores, do not bump or twist the cores.

Ducts should be inspected annually. Ensure all ducts and joints are free from damage, contaminants, or leaks in order for the system to behave properly.

6.1 MAINTENANCE AFTER 30 DAYS OPERATION

After 30 days of unit operation, check/tighten all mounting and support hardware. Inspect filters for cleanliness. There is often construction dust collected during initial operation. If filters appear dirty, replace them.

6.2 RECALIBRATION OF AIRFLOWS

Whenever there is a reconfiguration of the heating system in a residence, to include changing damper positions, the fan speed potentiometers on the EV Premium should be re-calibrated for optimum performance when not using a constant volume airflow setpoint. If the residence undergoes significant structural changes, such as an addition to the home, the EV Premium should also be re-calibrated. If optional MERV 13 filters are installed, recalibration is also required.

6.3 DOOR REMOVAL

The hinged door is held in place by two separable hinges on one edge and two security latches on the other edge. The separable hinges include a plastic clip to prevent accidental separation. To remove the door, first disconnect power to the unit. Unlatch and open the door and then strike the edge of the door, pushing the door toward the OA/EA side of the unit.

6.4 SERVICE PARTS

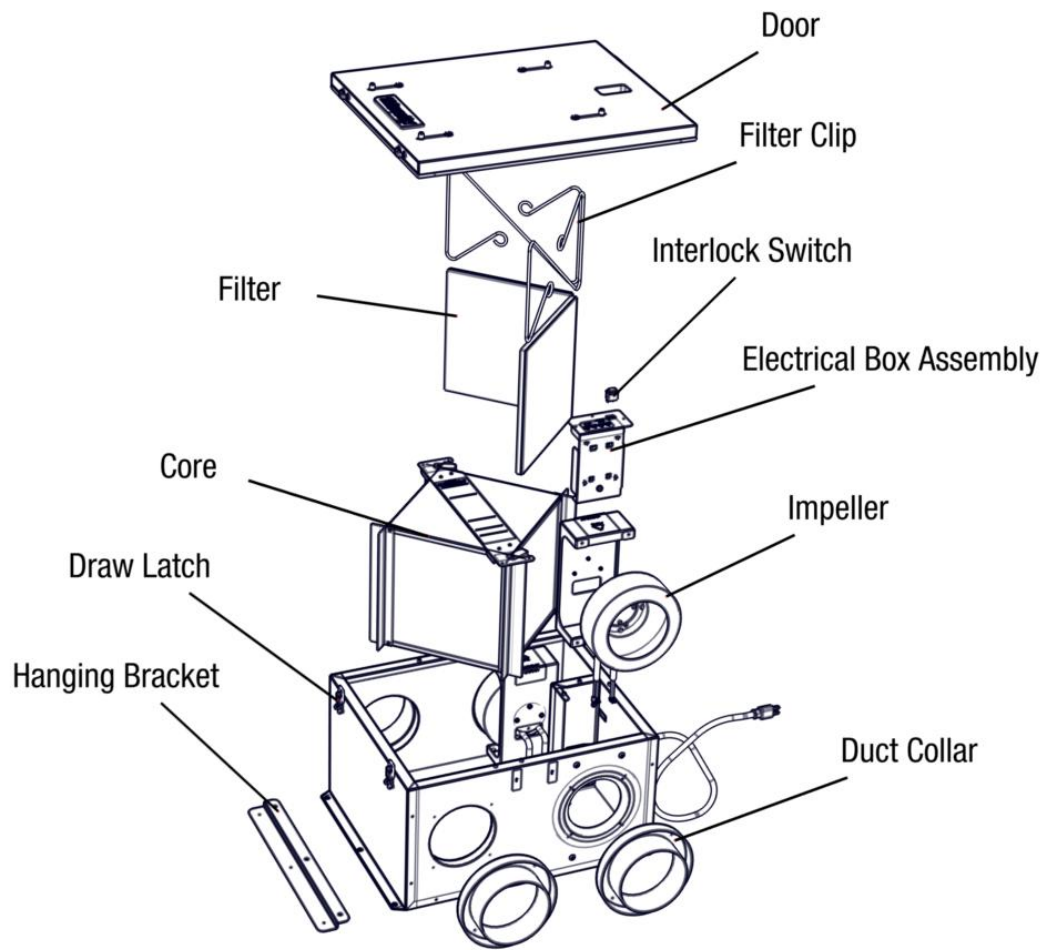

FIGURE 6.4.0 EV PREMIUM SERVICE PARTS

7.0 TROUBLESHOOTING

7.1 INDICATION OF PROBLEM

Indications of a problem with the ERV may be the perception that fresh air is not being delivered. The first step in resolving an apparent problem with an EV Premium ERV is to verify that there actually is a problem.

Regardless of the reason for thinking there is a problem with the EV Premium, the first steps in troubleshooting are to check the air filters to make sure they are clean and properly positioned, and then do a hard restart of the unit. A hard restart involves unplugging the unit for several seconds and then plugging it back in. It takes a few moments for the control board to discharge. After reapplying power, check to see if resetting the circuit has solved the problem.

Because there are many different ways of ducting the Supply Air into a dwelling, it is often difficult to say with certainty that the fresh air provided by the EV Premium is not reaching its intended destination or if the ERV is simply no longer providing enough fresh air. Determine where and how the fresh air is supposed to be delivered—if it is being carried in a dedicated duct directly to the air outlet, check for airflow at the outlet.

- Verify that dampers are still correctly positioned (open). If the ERV is being ducted into a main air handling system, shut the air handling system down so that airflow at the ducts can be detected.
- Check for airflow at the air openings nearest to the EV Premium, not at the far end of the house. It may be necessary to hold a thin strip of tissue paper in front of a vent to realize whether or not there is airflow.
- Check for airflow in both low speed and high speed settings. It will be easier to detect airflow in the high speed setting.
- Check ducts and duct runs and problems with bends, sagging, etc.

7.2 ERV HAS AIRFLOW BUT IS MAKING NOISE

Feel the EV Premium while it is running to see if there is excessive vibration from the fans. Fan noise and vibration can be caused by an imbalance in the rotors or possibly by a bad bearing. Turn off power to the unit and rotate the fan impellers by hand. Make sure impellers rotate freely. Use wet swabs to clean any dust/dirt buildup off the impeller blades. If problem continues, a fan may have a bad bearing.

7.3 NO APPARENT AIRFLOW FROM THE ERV

If it seems that there is no apparent airflow, verify that it has power.

- If it does not have power, trace the power supply back to its source and isolate the problem or symptoms. Look for a switch turned off, a blown fuse or a tripped circuit breaker. If necessary, use a multimeter to trace the power supply and isolate the problem.
- If it has power and the fans will not run, disconnect all power to the unit and check the disconnect switch with an ohmmeter.
- If it has power, check to see if the fans are running by listening for fan noise and feeling the unit for vibration from the fans.
- If it has power and the fans are running, check the filters to make sure they are clean. Check the entire length of the ducts, all the way from the outdoor vent hoods to the indoor vent openings. Make sure a duct has not fallen off or that a flexible duct has not been pinched. In rare cases, there may be obstructions inside the duct. Look to see if a louver in an outdoor vent cap is stuck or blocked or if an indoor louver has been shut.
- If it has power but only one fan is running, disconnect all power to the unit and check the fan connectors to make sure they are still making contact.

7.4 INADEQUATE OR REDUCED AIRFLOW FROM THE ERV

If the unit has power and both fans are running, use a manometer to check the pressure differential across the core. See Section 4.3 Balancing Airflows in this manual. The results of a pressure differential test will provide correct information on how much air the unit is moving and also how the volume of air compares to when the unit was first installed. Check both low speed and high speed settings by changing the jumpers on the low-voltage terminal strip, as shown in section 3.3 in this manual. Check ducts for bends, blockages, or leaks.

7.5 ERV FAILS TO RUN IN EITHER LOW SPEED OR HIGH SPEED MODE

The low-speed and high-speed modes operate independently of each other so there can be a failure in just one mode and it does not appear in the second mode. If one mode does not work, the problem can be isolated to either the controller or to an internal failure by bypassing the controller.

- ♦ Remove all wiring from the terminal strip as shown in Section 3.3 of this manual. Mark the wires so they can be reconnected in their proper locations.
- ♦ With no jumper present, check for proper operation.
- ♦ Install a jumper wire from the 24VAC terminal to the High Speed terminal. Check for proper operation. Remove the jumper wire and reinstall the control device wiring.

7.6 NO APPARENT REASON FOR LOW AIRFLOW

The final step in troubleshooting an ERV problem is to reset the fan potentiometers. Use a manometer and follow the instructions in Section 4.3 Balancing Airflows in this manual. Restore the pressure differential settings to their original airflow settings (CFM), as recorded in Section 4.4.

8.0 FACTORY ASSISTANCE

In the unlikely event that you need assistance from the factory for a specific issue, make sure that you have the information called for in the Unit Information page in the front of this manual. The person you speak with at the factory will need that information to properly identify the unit.

To contact RenewAire Customer Service:

Call 800-627-4499

Email: RenewAireSupport@RenewAire.com



About RenewAire

For over 40 years, **RenewAire** has been a pioneer in enhancing indoor air quality (IAQ) in commercial and residential buildings of every size. This is achieved while maximizing sustainability through our fifth-generation, static-plate, enthalpic-core **Energy Recovery Ventilators (ERVs)** that optimize energy efficiency, lower capital costs via load reduction and decrease operational expenses by minimizing equipment needs, resulting in significant energy savings. Our ERVs are competitively priced, simple to install, easy to use and maintain and have a quick payback. They also enjoy the industry's best warranty with the lowest claims due to long-term reliability derived from innovative design practices, expert workmanship and **Quick Response Manufacturing (QRM)**.

As the pioneer of static-plate core technology in North America, RenewAire is the largest ERV producer in the USA. We're **committed to sustainable manufacturing** and lessening our environmental footprint, and to that end our Waunakee, WI plant is 100% powered by wind turbines. The facility is also one of the few buildings worldwide to be LEED® Gold and Green Globes certified, as well as having achieved ENERGY STAR Building status. In 2010, RenewAire joined the Soler & Palau (S&P) Ventilation Group in order to provide direct access to the latest in energy-efficient air-moving technologies. For more information, visit: renewaire.com

201 Raemisch Road | Waunakee, WI | 53597 | 800.627.4499 | RenewAire.com