

# ENHANCED COMMERCIAL CONTROLS

## Installation, Operation and Maintenance Manual

For HE-Series, and LE-Series Units



Carel c.pCO Mini

Colored DIN Terminals

This manual applies to energy recovery ventilator (ERV) units with Enhanced controls version 4.xx.xx. For previous versions refer to the older manual. The version number can be seen on the splash screen when the unit power is cycled.



Newer units also have this version information in the *Unit Status* screens.

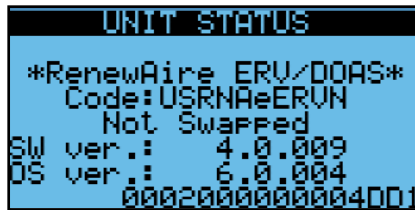

**⚠ WARNING****ARC FLASH AND ELECTRIC SHOCK HAZARD**

Microprocessor controllers as discussed in this manual are typically installed in a control panel where high voltages are present. Whenever accessing any controller, disconnect all electric power supplies, verify with a voltmeter that electric power is OFF and wear protective equipment per NFPA 70E when working within the electric enclosure. Failure to comply can cause serious injury or death.

The line side of the disconnect switch contains live high-voltage.

The only way to ensure that there is NO voltage inside the unit is to install and open a remote disconnect switch and verify that power is off with a voltmeter. Refer to unit electrical schematic.

Follow all local codes.

**⚠ CAUTION****RISK OF ELECTRIC SHOCK OR EQUIPMENT DAMAGE**

Whenever electrical wiring is connected, disconnected or changed, the power supply to the ERV and its controls must be disconnected. Lock and tag the disconnect switch or circuit breaker to prevent accidental reconnection of electric power.

**⚠ CAUTION****RISK OF COMPUTER SECURITY BREACH**

This controller is capable of being connected to a network. Any device that is connected to a network is susceptible to unauthorized access and hostile activities. It is the owner's responsibility to determine acceptable risks and to safeguard the security of the controller and all connected devices.

**IMPORTANT**

This controller is only for use in protected environments. It is not to be exposed to the weather or exposed to extremes in temperature.

**IMPORTANT**

Risk of degraded unit efficiency. Improper adjustment of unit setpoints may result in the ERV operating inefficiently. Improper selection of Input Offsets may cause incorrect or inefficient operation of the ERV.

**IMPORTANT**

Only persons who have been properly trained and authorized are to access the ERV control panel and the controller. Changes to the controller settings are to be made only by trained and authorized personnel. All changes to the controller settings are to be documented in the Controller Maintenance Records section in this manual.

**IMPORTANT**

This control system is subject to periodic updates in firmware and the User Manual itself. Please contact RenewAire Support at [RenewAireSupport@RenewAire.com](mailto:RenewAireSupport@RenewAire.com) to determine if you have the most recent manual and firmware.





<b>1.0 OVERVIEW</b>	<b>9</b>	<b>6.1 FROST CONTROL</b>	<b>27</b>
1.1 CONTROL SEQUENCE OVERVIEW	9	6.2 SINGLE FAN MODE	28
1.2 ENERGY RECOVERY BASICS	9	6.3 USE ROOM TEMP AND HUMIDITY RATHER THAN RETURN	28
1.3 TEMPERATURE SENSORS	10	6.4 FLUSH FEATURE	28
1.4 COMBINATION TEMPERATURE AND HUMIDITY TRANSDUCERS	10	6.5 COLD WEATHER OPERATION	29
1.5 CURRENT SENSORS	11	6.6 ECONOMIZER CONTROL (BYPASS/FREE COOLING)	30
1.6 FILTER MONITORING	12	6.6.1 Economizer Based on Temperature Difference Sequence	31
1.7 SENSOR LOCATIONS	13	6.6.2 Economizer based on Enthalpy Difference Sequence	32
<b>2.0 CONTROLLER OVERVIEW</b>	<b>14</b>	6.6.3 Economizer Based on OA Temperature Limits	32
2.1 CONTROLLER ACCESS METHODS	15	6.6.4 Economizer Based on OA Enthalpy Limits	32
2.1.1 Using the Remote User Terminal (RUT)	15	6.7 SMOKE OR FREEZESTAT DEDICATED INPUT	33
2.1.2 Connecting Using Internal Web Pages	16	6.8 BOOST MODE	34
2.1.3 Setting the PC IP Address	17	6.9 SMOKE PURGE	34
2.1.4 Using the Multikey Function of the Web Pages	18	6.10 SWAP AIRFLOWS	35
2.2 CONTROLLER MENU STRUCTURE	18	6.11 UNIT ON/OFF OUTPUT	35
2.2.1 User Menu Structure	18	<b>7.0 VERIFYING I/O AND UNIT WIRING</b>	<b>36</b>
2.2.2 Password Protected Menu Structure	19	7.1 VERIFYING ALL I/O THROUGH UNIT STATUS SCREENS	36
2.2.3 Password Entry	19	7.2 CALIBRATING I/O	36
<b>3.0 GENERAL FLOW FOR SETUP AND RUNNING UNIT</b>	<b>19</b>	7.3 GENERAL UNIT CONTROL WIRING	36
<b>4.0 UNIT CONFIGURATION</b>	<b>20</b>	7.3.1 Sensor Inputs	37
4.1 CONFIGURE GENERAL SETTING	20	7.3.2 Digital Inputs	37
4.1.1 Setting the Time and Date	20	7.3.3 Digital Outputs	38
4.1.2 Setting the Unit of Measure	20	7.3.4 Analog Outputs	38
4.1.3 Setting the IP Address of the Controller	20	7.3.5 Sample Power Wiring Schematic	39
4.1.4 Scheduler	21	7.3.6 Sample Control Wiring Schematic	40
4.2 VERIFY UNIT CONFIGURATION	21	7.3.7 Sample Field Wiring Schematic	41
4.2.1 Main Unit Configuration	21	<b>8.0 ALARMS AND TROUBLESHOOTING</b>	<b>42</b>
4.2.2 I/O Configuration	22	8.1 ALARMS	42
4.2.2.1 Digital Inputs	22	8.1.1 Acknowledging Alarms	42
<b>5.0 UNIT OPERATION AND FAN CONTROL</b>	<b>23</b>	8.1.2 Viewing Alarms and Alarm Log	42
5.1 SEQUENCE OF OPERATION FOR UNIT START	23	8.1.3 Resetting Alarms	43
5.1.1 Digital Input (ID1) Unit On/Off	24	8.1.4 Alarm Digital Outputs	43
5.1.1.1 Optional Smoke Detector	24	8.1.5 Specific Alarms and Their Meaning	44
5.1.1.2 Optional Motion Sensor	25	8.1.5.1 General Alarms	44
5.1.2 Isolation Dampers	25	8.1.5.2 Supply and Exhaust Alarms	45
5.1.3 Fans	25	8.1.5.3 Airflow Condition Alarms	45
5.2 OPTIONS FOR SUPPLY FAN CONTROL	25	8.1.5.4 Sensor Alarms	46
5.2.1 Constant Fan Speed Option	25	8.1.5.5 Filter Alarms	46
5.3 OPTIONS FOR EXHAUST FAN CONTROL	26	8.1.5.6 Maintenance Alarms	47
5.3.1 Constant Fan Speed Option	26	8.2 TEST END DEVICES	47
5.3.2 Supply Fan Command Tracking Control Option	26	8.2.1 Supply or Exhaust Fan Alarm Troubleshooting	47
<b>6.0 SPECIAL FEATURES</b>	<b>26</b>	8.3 OTHER COMMON PROBLEMS	49
		8.3.1 Unit Not On	49
		8.3.2 Sensor Reading ##### or Has Extreme Value	49
		8.3.3 BMS Loss of Comm after Param Change or Restore	49
		8.3.4 Can Not See Device via IP Connection	49

<b>8.4 TESTING FUNCTIONS IN GENERAL.....</b>	<b>50</b>	11.6.1 Obtaining a BACnet License.....	71
<b>8.5 RESTORE PARAMETERS (SETTING) .....</b>	<b>50</b>	11.6.2 Installing the BACnet License via Web Page.....	71
8.5.1 User Commissioning Settings (Service).....	50	11.6.3 Installing the BACnet License via USB Drive.....	72
8.5.2 Restore Factory Settings .....	51	11.6.4 Installing the BACnet License via USB Connection.....	72
8.5.3 General Save and Restore.....	51	<b>11.7 MODBUS .....</b>	<b>72</b>
8.5.4 Code List for Save and Restore .....	52	11.7.1 Modbus TCP Connection .....	72
8.5.5 Return to Program Defaults.....	52	11.7.2 Modbus TCP Settings .....	73
<b>9.0 ACCESSING FILES FROM AND</b>		11.7.3 Modbus RTU Settings .....	73
<b>PERFORMING UPDATES TO</b>		11.7.4 Modbus RTU Wiring .....	73
<b>THE CONTROLLER</b>	<b>54</b>	<b>11.8 MODBUS REGISTER LIST .....</b>	<b>74</b>
<b>9.1 CONNECTIONS USING THE MICRO USB PORT .....</b>	<b>54</b>	<b>11.9 MODBUS APPLICATION NOTES .....</b>	<b>75</b>
<b>9.2 ALARMS AND DATA LOGS .....</b>	<b>55</b>	11.9.1 Turning the Unit ON and OFF.....	75
9.2.1 Example of Alarm Log .....	55	11.9.2 Alarms.....	76
9.2.2 Example of Data Log.....	55	11.9.3 Temperature and Humidity Around the ERV.....	76
<b>9.3 VIEWING PARAMETER FILES .....</b>	<b>56</b>	11.9.4 Fan Control .....	77
<b>9.4 PERFORMING UPDATES TO THE CONTROLLER .....</b>	<b>56</b>	11.9.5 BMS Direct Fan Control.....	77
9.4.1 Upgrade Type: Connect via USB .....	57	11.9.6 Frost Control.....	78
9.4.2 Upgrade Type: Connect with a USB Thumb Drive .....	57	11.9.7 Filter Monitoring.....	78
9.4.3 Upgrade Type: Connect via Ethernet.....	58	11.9.8 Exhaust Fan Only Mode.....	78
<b>10.0 GENERAL SYSTEM MONITORING</b>	<b>59</b>	<b>12.0 ADVANCED SERVICE</b>	<b>79</b>
<b>10.1 MAIN SCREEN .....</b>	<b>59</b>	<b>12.1 RUN HOURS AND STARTS .....</b>	<b>79</b>
<b>10.2 OTHER STANDARD SCREENS .....</b>	<b>59</b>	<b>12.2 LAST POWER LOSS.....</b>	<b>79</b>
<b>10.3 FAN AND UNIT STATUS SCREENS.....</b>	<b>59</b>	<b>12.3 INTERNAL MEMORY WRITES .....</b>	<b>79</b>
<b>10.4 FROST CONTROL INFORMATION.....</b>	<b>60</b>	<b>12.4 ALARM INITIALIZATION .....</b>	<b>79</b>
<b>10.5 ENTRY TO THE I/O INFORMATION SCREEN.....</b>	<b>61</b>	<b>12.5 MEMORY WIPE .....</b>	<b>80</b>
<b>10.6 VERSION INFORMATION SCREEN.....</b>	<b>61</b>	<b>13.0 MAINTENANCE RECORDS</b>	<b>81</b>
<b>11.0 BMS ACCESS</b>	<b>62</b>	<b>13.1 UNIT START UP CONDITIONS.....</b>	<b>81</b>
<b>11.1 SETTING CONTROL LEVEL.....</b>	<b>62</b>	13.1.1 Setpoints.....	81
<b>11.2 SETTING BMS TYPE .....</b>	<b>62</b>	13.1.2 Offsets.....	81
<b>11.3 BACNET .....</b>	<b>63</b>	13.1.3 IP Addresses .....	81
11.3.1 BACnet IP Connection.....	63	<b>13.2 CHANGES MADE TO UNIT AFTER START UP .....</b>	<b>82</b>
11.3.2 BACnet IP Settings.....	63	13.2.1 Setpoints .....	82
11.3.3 BACnet MSTP Settings.....	64	13.2.2 Offsets.....	82
11.3.4 BACnet MSTP Wiring.....	64	13.2.3 I/O Configuration Changes .....	82
<b>11.4 BACNET OBJECT LIST .....</b>	<b>65</b>	<b>13.3 CONTROLLER UPDATES .....</b>	<b>83</b>
<b>11.5 BACNET APPLICATION NOTES .....</b>	<b>67</b>	<b>13.4 SETTINGS BACKUP FILE.....</b>	<b>83</b>
11.5.1 Turning the Unit On and Off .....	67	<b>14.0 REFERENCE</b>	<b>84</b>
11.5.2 Alarms.....	68	<b>14.1 TUNING PI CONTROL LOOPS .....</b>	<b>84</b>
11.5.3 Temperature and Humidity Around the ERV.....	68	14.1.1 Proportional Constant (KP).....	84
11.5.4 Fan Control .....	69	14.1.2 Time Integral (Ti).....	85
11.5.5 BMS Direct Fan Control.....	69	14.1.3 Establish a KP Setting .....	86
11.5.6 Economizer Control .....	70	14.1.4 Establish a Ti Setting.....	86
11.5.7 Frost Control.....	70	14.1.5 Verify the Combined KP and Ti Settings .....	86
11.5.8 Filter Monitoring .....	70	<b>14.2 TEMPERATURE SENSOR CURVE .....</b>	<b>89</b>
11.5.9 Exhaust Fan Only Mode.....	70	<b>14.3 HE-SERIES FULL CONFIGURATION CODE .....</b>	<b>90</b>
<b>11.6 ADDING A BACNET LICENSE.....</b>	<b>71</b>	<b>14.4 LE-SERIES FULL CONFIGURATION CODE.....</b>	<b>92</b>
		<b>15.0 GLOSSARY</b>	<b>94</b>

**TABLE OF ILLUSTRATIONS**

---

Figure 1.3.0 Duct Temperature Sensor .....	10
Figure 1.4.0 Temperature and Humidity Sensor .....	10
Figure 1.5.0 Current Switch .....	11
Figure 1.7.0 Sensor Locations in ERV Units, HE10INV Shown.....	13
Figure 2.0.0 C.PCO Controller Buttons .....	14
Figure 2.0.1 Controller External Connections.....	14
Figure 2.1.0 Optional Remote User Terminal (RUT).....	15
Figure 2.1.1 Connecting a RUT .....	16
Figure 5.1.0 Smoke Detector.....	24
Figure 5.1.1 Motion Sensor (Ceiling Mount).....	25
Figure 5.1.2 Motion Sensor (Wall Mount).....	25
Figure 11.2.0 Ethernet Connection .....	72
Figure 14.1.0 KP Setpoint Charts.....	85
Figure 14.1.1 KP Adjustment Worksheet .....	87
Figure 14.1.2 Ti Adjustment Worksheet .....	88

## 1.0 OVERVIEW

### 1.1 CONTROL SEQUENCE OVERVIEW

The Renewaire ERV with enhanced controls provides outdoor air while saving energy by passing the exhaust air through the energy recovery core to exchange energy with the incoming air, with energy being passed to the incoming air in the winter and energy being passed to the outgoing air in the summer. Pairing this with the factory-programmed enhanced controller provides an excellent turn-key solution with the following control options.

1. Turning the unit off and on based on
  - ♦ A digital input (smoke detector, occupancy sensor, etc)
  - ♦ The controller keypad
  - ♦ Schedule
  - ♦ A BMS system, if the feature is enabled
  - ♦ Alarm status
2. Isolation damper control (if option is included)
3. Supply and exhaust fan control
  - ♦ On/Off fan control for constant speed fans
  - ♦ Variable speed fan control for variable speed and ECM fans (set as a percentage)
  - ♦ Supply or exhaust fan tracking
  - ♦ Single fan operation with digital input or BMS command
4. Supply and Exhaust Fan status via current sensors
5. Monitoring of these values
  - ♦ Outdoor Air (OA) Temperature
  - ♦ Outdoor Air (OA) Relative Humidity
  - ♦ Return Air (RA) Temperature
  - ♦ Return Air (RA) Relative Humidity
  - ♦ Supply Temperature (SA)
  - ♦ Exhaust Temperature (EA)
6. Monitoring of pressure across filter for filter status
7. Bypass control for economizer control, if the option is available
8. Alarm alerts and logging

### 1.2 ENERGY RECOVERY BASICS

#### IMPORTANT

It is important to understand and use the equipment airstream terminology as it is used in this manual. The airstreams are defined as:

- ♦ Outside Air (OA): Air taken from the external atmosphere and, therefore, not previously circulated through the system.
- ♦ Supply Air (SA): Air that is downstream of the enthalpic cores.
- ♦ Return Air (RA): Air that is returned from a conditioned space.
- ♦ Exhaust Air (EA): Air that is discharged. Each ERV unit has an EA outlet.



**NOTE:** This unit has a microprocessor controller. It is commonly referred to as a "controller."



**NOTE:** Many of these control features require the use of optional sensors. The unit configuration will determine the availability of some functions.

RenewAire energy recovery ventilators use static-plate, enthalpy-core heat exchangers that have no moving parts.

- During summer months, the hot and humid OA passes by the cooler, drier RA, lowering its temperature and humidity.
- During winter months, the cold and dry OA passes by the warmer, moister RA, raising its temperature and humidity.

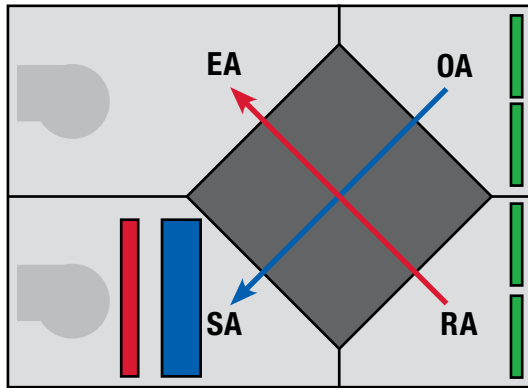

### 1.3 TEMPERATURE SENSORS

There are multiple temperature sensors installed in each ERV. These are NTC sensors that have a Carel curve. The curve characteristics can be found in the Reference section. They are located at:

- One in the EA section
- One in the SA section



FIGURE 1.3.0 DUCT TEMPERATURE SENSOR

### 1.4 COMBINATION TEMPERATURE AND HUMIDITY TRANSDUCERS

Temperature and humidity transducers are mounted in the OA and RA compartments and provide a temperature sensor output and a 0-10 VDC output that is proportional to 0–100% Relative Humidity.



FIGURE 1.4.0 TEMPERATURE AND HUMIDITY SENSOR

## 1.5 CURRENT SENSORS

Current sensors are installed on high voltage supply wires to sense current going to a fan motor. They are used to prove the ON/OFF state of fan motors.



FIGURE 1.5.0 CURRENT SWITCH

When the unit starts, this screen will show when the fans are enabled. There is a slight delay of a few seconds, and then the second line, *supply (or exhaust) fan on* shows the status of the current sensor.

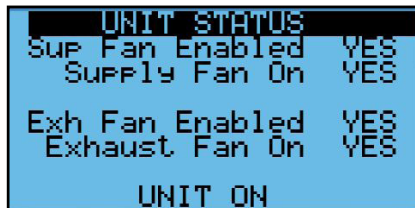

The current sensors are factory adjusted and may need to be field-adjusted for the application. This will be evidenced by getting a supply fan alarm (AL10) or exhaust fan alarm (AL11). The instructions are in the Alarms and Troubleshooting section of this manual.



**NOTE:** Current sensors are calibrated for reduced fan speed at time of shipment from the factory. Immediately after entering new operating parameters for the fans (done during the start up process), current sensors are to be re-calibrated for minimum current draw. The fan should be running at its minimum speed that will be experienced during normal operation.

### 1.6 FILTER MONITORING

There is a pressure transducer across the filters on the OA and RA streams to monitor the filter status. The scaling is factory set in this screen.



```

I/O Configuration
Filter Press Scaling
OA Flt 0 U= 0.0"wg
          10 U= 2.0"wg

RA Flt 0 U= 0.0"wg
          10 U= 2.0"wg
    
```

The alarm level is set in this screen. This alarm does not stop the unit from running.

```

ALARM SETTINGS
Filter Alarms

OA Level      1.0"wg
RA Level      1.0"wg
Alarm Delay   60 sec
    
```

You can also see the pressure in this screen so that if it gets close to the alarm level you can change it at your convenience.

```

UNIT STATUS
OA Humidity    25.0%
RA Humidity    22.3%
OA Enthalpy    21.8btu/lb
RA Enthalpy    21.3btu/lb
OA Filter      0.02"wg
RA Filter      0.05"wg
SA Temperature 68.7f
    
```

1.7 SENSOR LOCATIONS

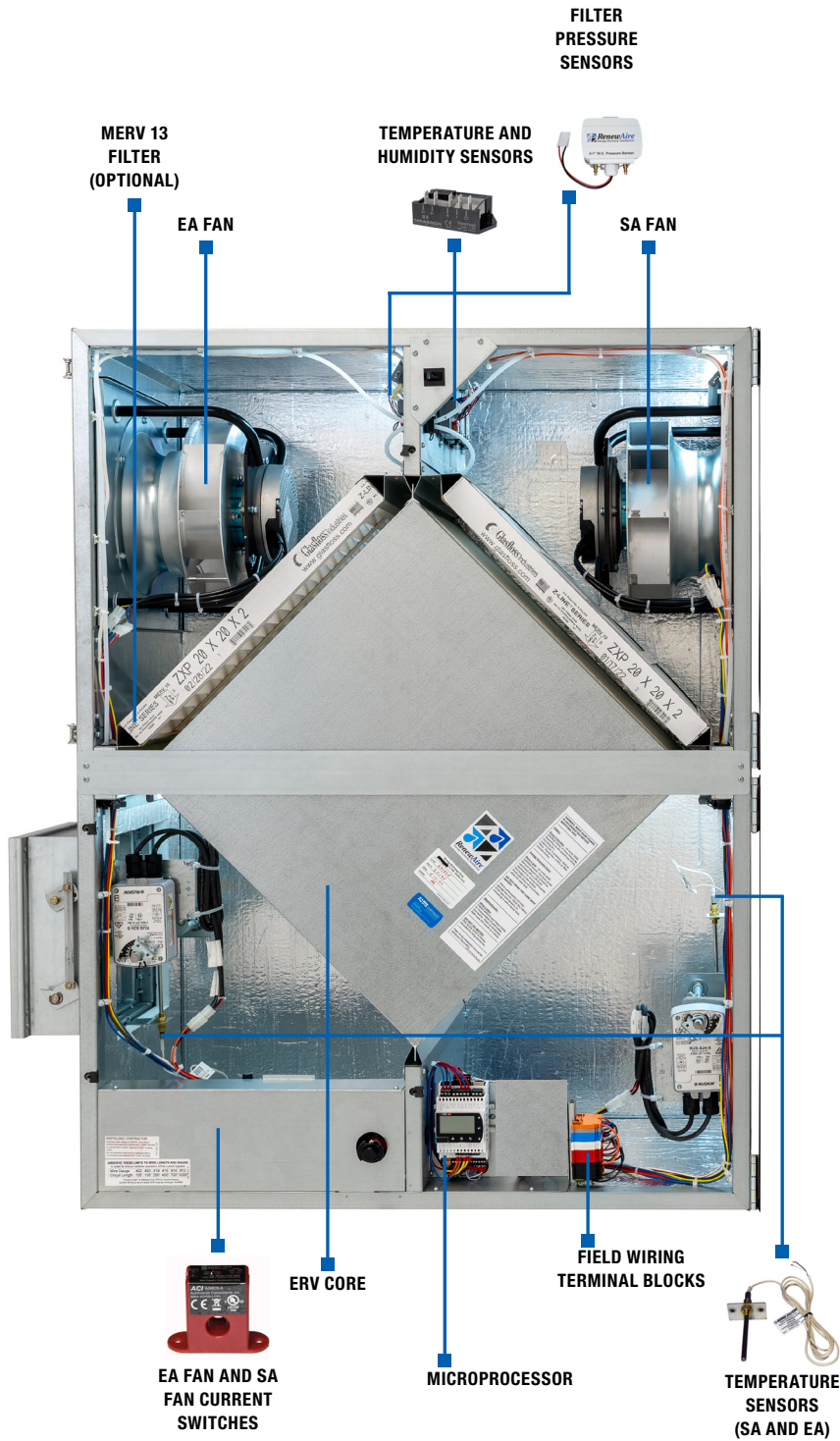

**NOTE:** Not shown here are the Smoke Detector, CO2, IAQ, Duct Pressure Sensor, Room Temperature and Humidity Sensor, and Motion Detector. These items are all accessories and are field-installed.

FIGURE 1.7.0 SENSOR LOCATIONS IN ERV UNITS, HE10INV SHOWN

## 2.0 CONTROLLER OVERVIEW

The control utilizes the Carel c.pco (pronounced see-pee-ko) controller.

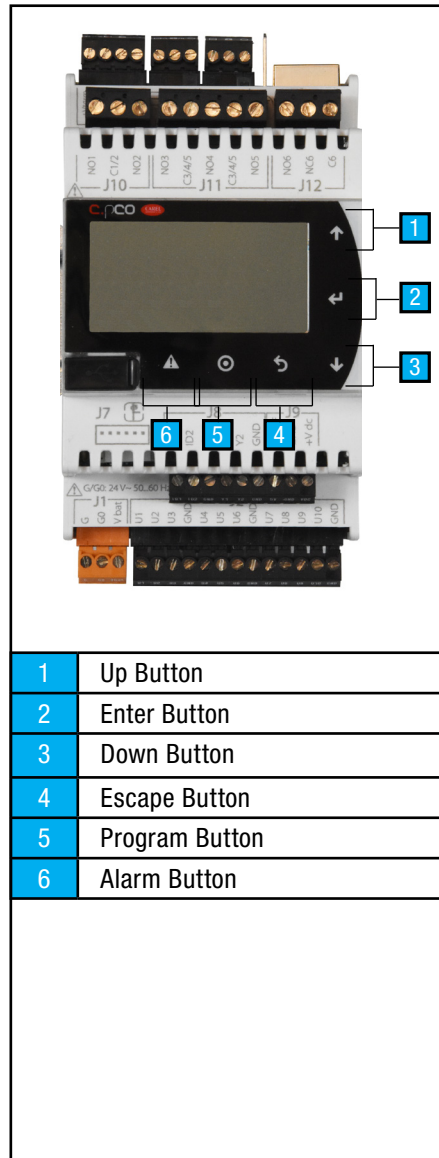

FIGURE 2.0.0 C.PCO CONTROLLER BUTTONS

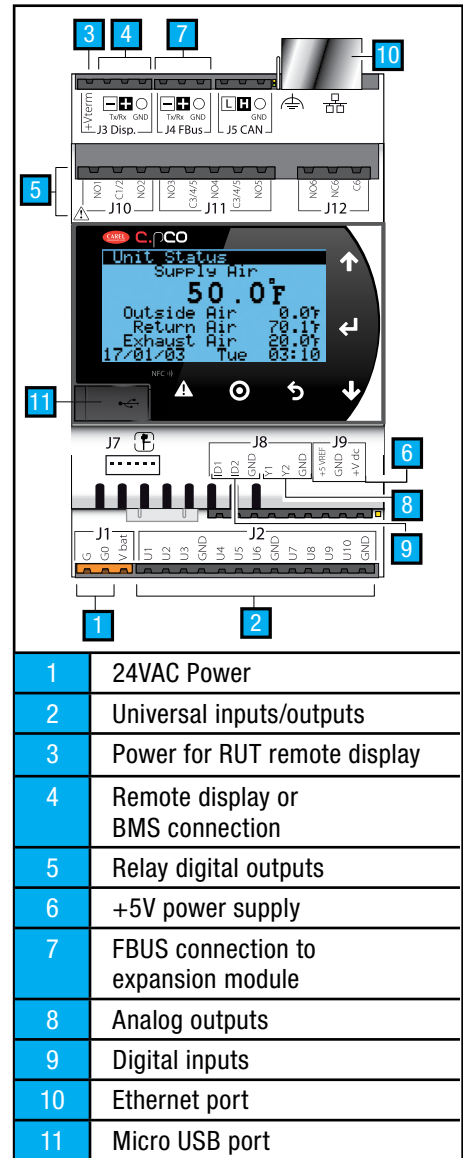

FIGURE 2.0.1 CONTROLLER EXTERNAL CONNECTIONS



Pressing the PRG (program) button accesses the Service Menu or Login screen from any location in the user interface screens. The options that are available dynamically change depending on the configuration of the unit and the options installed on the unit.



The ESC button is used to go one level back from the screen the user is currently on. If the user is finished setting variables in a sub-menu, the ESC button takes them back to the previous menu. If the user is editing a variable and decides to not make a change, the ESC button takes them back to the top of that screen. Pressing the ESC button from the Main Menu takes the user back to the Main Status screen.



When on a screen with the cursor in the upper left-hand corner, the UP or DOWN hard buttons move the user from one screen to the next. While editing a variable, the UP or DOWN hard buttons allow the user to set the desired value of the variable. When viewing a view only variable, the UP or DOWN hard buttons scroll through the values available to the user.



When a menu or menu item has been highlighted, press the “ENTER” hard button to enter the highlighted selection. When a writable entry has been changed, press the hard button to enter the new value and then press it again to confirm the change.



Pressing the ALARM button displays any alarms that are currently active. There may be multiple screens of alarms. Pressing and holding the Alarm button for three seconds resets the alarms.



**NOTE:** When an alarm is first detected, the Alarm button will be flashing and an audible alarm will sound. After the alarm has been viewed, the light will remain on and the audible alarm will stop.

## 2.1 CONTROLLER ACCESS METHODS

The controller has a built-in display that can be used to set up the system and view the status of the system as well as address alarms. Two other options for accessing these are through the remote RUT and through the embedded web pages. All three methods use similar keys for the same purpose.

### 2.1.1 Using the Remote User Terminal (RUT)

The Remote User Terminal (RUT) allows you to plug into a controller and see the screens from that controller. RUTs are connected to the controller by means of a 10' cable and then used as hand-held devices. They can alternately be installed on a wall in some convenient location. The push buttons on the face of the RUT have the same functions as the push buttons on the controller.



FIGURE 2.1.0 OPTIONAL REMOTE USER TERMINAL (RUT)

The RUT (optional accessory, field-installed) plugs into the controller by means of a six wire cable with RJ12 jacks on each end. The six-wire cable is inserted in the RJ12 jack on the back of the RUT and the other end of the cable is inserted into the RJ12 adapter. The controller uses a pre-configured cable that plugs into the J3 jack on the controller and the other end is plugged into the RJ12 adapter. The cable looks similar to a standard phone cable but has a different pin out. The cable and coupler from the controller to the low voltage electrical box is included with the RUT.

**NOTE:** Common telephone wiring is 4 conductor and uses RJ11 terminals. It is different from the six-wire cable with RJ12 terminals needed for this accessory.

**NOTE:** If the controller was ordered for use with a serial BMS and an RUT is also desired, contact the factory for further information.

**NOTE:** For direct connection from RUT to J3 Terminal, use the following wiring:  
 Blue & White = +Vterm  
 Yellow & Black = GND  
 Green = Positive (+)  
 Red = Negative (-)

**NOTE:** The controller will only support private IP addresses which start with 192, 172, or 10.

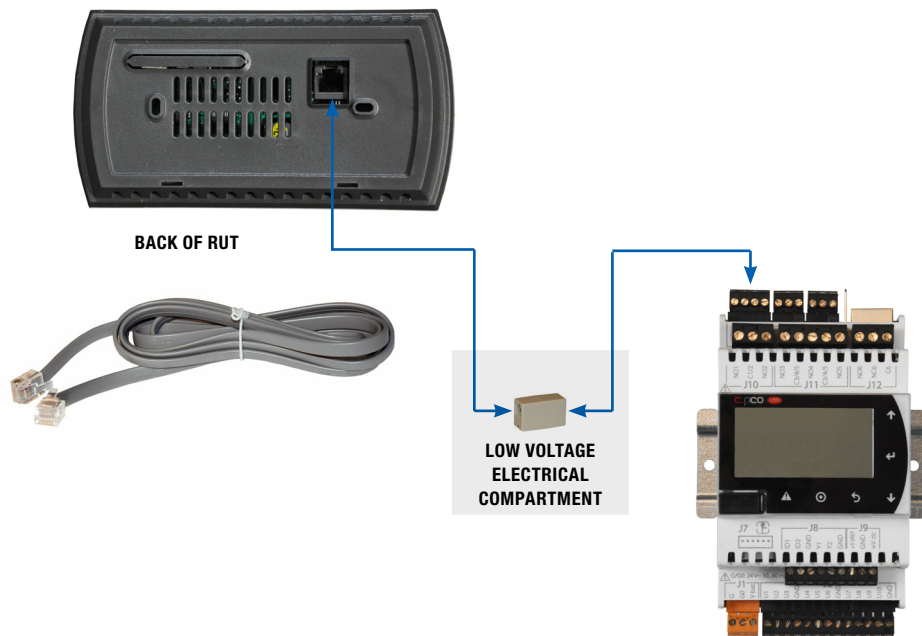

FIGURE 2.1.1 CONNECTING A RUT

2.1.2 Connecting Using Internal Web Pages

The controller has embedded web pages and when they are accessed, an interactive screen appears that allows the user to move through all the controller menus. The IP address of the controller is factory-set at 10.10.1.2. The subnet address (needed for setting up a LAN) is set at 255.255.255.0. These can be changed in the *General Settings* menu.

In order to connect to the controller with your pc you will need:

- An ethernet cable between the PC and the controller
- The PC connection must be on the same subnet as the controller. For example, if using the defaults, you would set the IP address of the PC connection to 10.10.1.xx where xx is not equal to 2, and the subnet to 255.255.255.0. (See directions for setting the PC IP address if you are not familiar with this.)

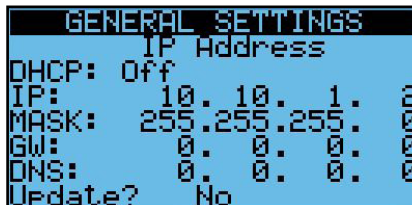

- Using a browser such as Chrome, put the controller IP address into the address bar.



You should see this web page. To get to the menu screens, click on RUT on the Menu Bar.



### 2.1.3 Setting the PC IP Address

For those that are not familiar with changing their PC adapter settings, go into Network Setting in the Control Panel and *Change Adapter Settings*.

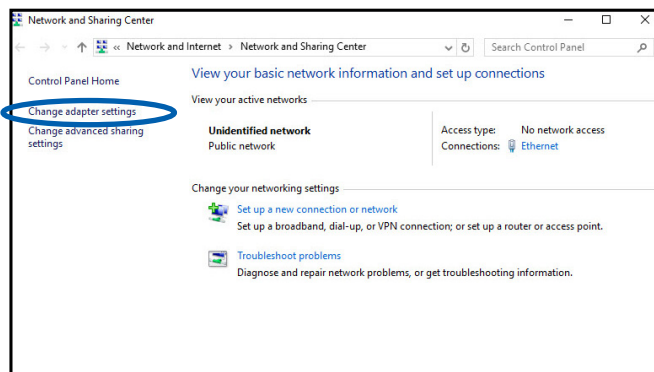

Choose the adapter you are using to connect to the controller.

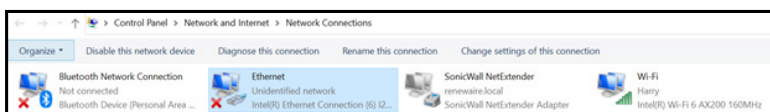

**NOTE:** When you are finished viewing the controller on your computer, remember to restore the original settings.

Select Internet Protocol 4 and click on Properties.

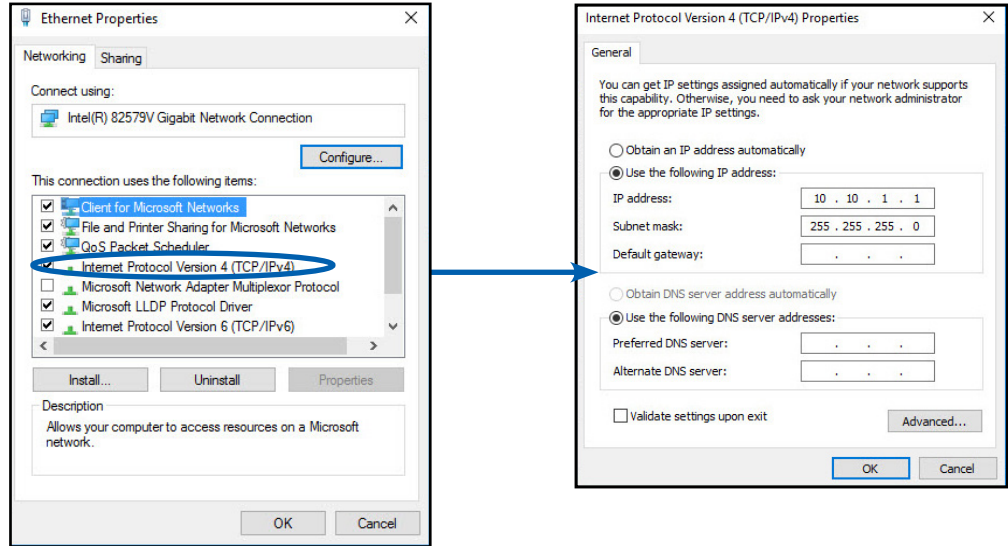

Enter the IP address you want to use. It should not be identical to the controller IP address. The last octet of the IP address should be different. Click "OK".

2.1.4 Using the Multikey Function of the Web Pages

When you want to press multiple keys or press a key longer for a function you can use the keys below the Menu Screens to do this.

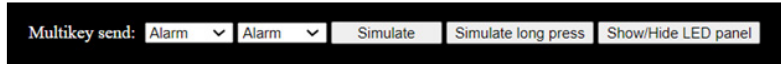

Two common uses are:

- Set the two keys to Alarm and Alarm and press *Simulate long press* to acknowledge alarms.
- Set the two keys to Alarm and Enter and press *Simulate long press* to get to system menus.

2.2 CONTROLLER MENU STRUCTURE

Any screen will have the name of the menu to which it belongs on the top line of the screen.

2.2.1 User Menu Structure

The user menu can be reached but pressing the ESC (back) button. The menus contain the following areas:

- *Unit Status*—Contains the status values of the sensors, fans, and heating and cooling, if applicable
- *Control Settings*—Contains the control settings for the fans and heating and cooling, if applicable
- *General Settings*—Contains the clock settings, Unit of Measures, IP Address, BMS settings, and the scheduler
- *Alarm Settings*—Contains the alarm settings
- *Unit On/Off*—Allows the user to turn the unit on and off via the keypad

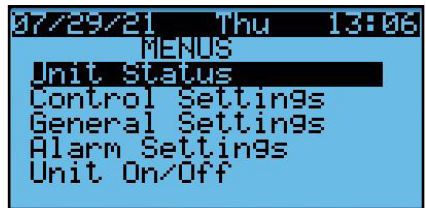

2.2.2 Password Protected Menu Structure

The password protected menu can be reached but pressing the ' button and entering the password. The menus contain the following areas:

- Back Up and Restore—Contains the screens to back up your settings or return to factory defaults
- Unit Configuration—Main Unit Configuration Settings that determine which screens show up in other areas
- I/O Configuration—Secondary configuration settings for functions
- I/O Calibration—Allows sensors to be adjusted for accuracy
- Sensor Overrides—Allows a sensor value to be temporarily overwritten for testing
- Test End Devices—Allows outputs to be manually manipulated for troubleshooting
- Advanced Service—Advanced Service Information and Settings

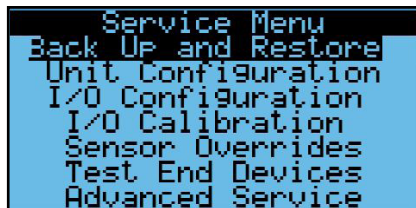

2.2.3 Password Entry

To access the password protected service screens, press the program (bullseye) button to get to the screen and enter the user password “1000.”



3.0 GENERAL FLOW FOR SETUP AND RUNNING UNIT

Depending upon features selected for the unit, the general flow for setup and running the unit is as follows:

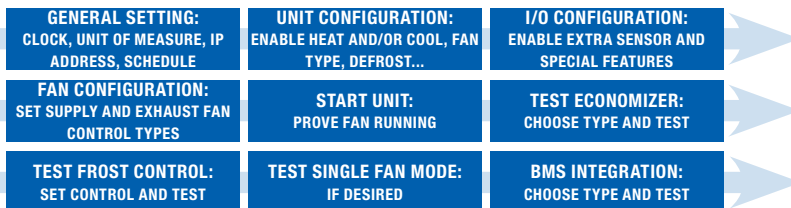

## 4.0 UNIT CONFIGURATION

### 4.1 CONFIGURE GENERAL SETTING

There are several general settings that are need for correct operation of the controller.

#### 4.1.1 Setting the Time and Date

It is important to have the correct time and date for alarm time stamps and logging.

- Set Refresh to “YES,” It will turn back to “NO” after changing the display to the current controller time and date.
- Change the Time and Date accordingly. (Day is automatically generated.)



#### 4.1.2 Setting the Unit of Measure

The controller supports the following settings:

- SI (bar, Celsius)
- USA (psi, Fahrenheit)
- UK (bar, Celsius)
- CAN (psi, Celsius)

Set the Unit of Measure to the desired units for the display.



#### 4.1.3 Setting the IP Address of the Controller

The controller IP address may be used for the BMS, networking, or local access.

- Set the DHCP to “OFF” if using a static IP
- Set the IP address and Mask
- Set Update to “YES”
- Cycle power to the controller

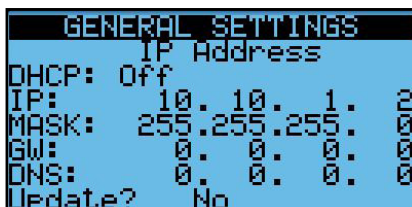

#### 4.1.4 Scheduler

Enable the scheduler, if desired. If you enable the scheduler, it will have to be set for “ON” for the unit to run along with all other “ON” conditions.

- Enable the scheduler by setting to “YES”.
- Set the schedule for each day. You can use the copy feature to copy days. Save data after each.
- Set vacation periods.
- Set Special Days.

The image shows four sequential screenshots of the unit's configuration interface, each with a black header and a blue background.

**GENERAL SETTINGS**  
 SCHEDULER  
 Enable? Yes  
 18:29 WED 03/09/2022  
 Sched. is not running  
 Sched status:

**DAILY EVENTS**  
 Day: Monday  
 Copy to: MON Ok? No  
 1 --:-- --  
 2 --:-- --  
 3 --:-- --  
 4 --:-- --  
 Save data? No

**VACATIONS PERIODS**  

	Start	End	Status
<input type="checkbox"/>	--/--	--/--	---
<input type="checkbox"/>	--/--	--/--	---
<input type="checkbox"/>	--/--	--/--	---

**SPECIAL DAYS**  
 1 --/-- --  
 2 --/-- --  
 3 --/-- --  
 4 --/-- --  
 5 --/-- --  
 6 --/-- --

## 4.2 VERIFY UNIT CONFIGURATION

### 4.2.1 Main Unit Configuration

It is important to verify the configuration as the settings on the screen will also determine which screens show up in the user settings screens.

- Unit Type: Enhanced
- Bypass Damp: Disable/Enable
- BP Type: Two-Position
- BP Seq: Internal/External
- Isolation Damp: Disable/Enable
- Enable Heat: No
- Enable Cool: No

```

UNIT CONFIGURATION
Unit Type: Enhanced
Bypass Damp: Disable
BP Type: Two-Position
BP Seq: INTERNAL
Isolat Damp: Enable
Enable Heat: NO
Enable Cool: NO

```

On this screen, if the fans are variable speed, these settings will be set to Yes.

```

UNIT CONFIGURATION
Var Speed SF? YES
Var Speed EF? YES

```

On this screen, if you want the unit to perform frost control, select YES. The units will cycle the supply fan to prevent frost. All of the settings are in the control settings area.

```

UNIT CONFIGURATION
Enable Frost Cntl:
NO

```

#### 4.2.2 I/O Configuration

##### 4.2.2.1 Digital Inputs

It is important to verify the configuration as the settings on the screen will also determine functionality and which screens show up in the user settings screens.

In this screen, set the use for the two digital inputs on the main controller. The defaults are shown. Consult the Special Features section for more information and additional settings for each function. The settings should be different.

- Choices for ID1: DI On/Off, Smoke Alarm, Freezestat, Boost Mode, H2O Leak Detect, Smoke Purge.
- Choices for ID2: Sing Fan Mode, Smoke Alarm, Freezestat, Boost Mode, H2O Leak Detect, Smoke Purge.

```

I/O CONFIGURATION
Dig Inputs Used For
ID1:DI On/Off
ID2:Sing Fan Mode
Must be different!

```

## 5.0 UNIT OPERATION AND FAN CONTROL

The primary purpose of the ERV unit is to provide 100% OA. The amount of air that it provides is based on the configuration of the supply and exhaust fans and whether the unit is running or not.

Fans are either controlled with variable speed drives or ECM motors.

### 5.1 SEQUENCE OF OPERATION FOR UNIT START

The unit will start when all of the following conditions are true:

- There are no serious alarms.
- The Digital Input for start/stop (orange DIN terminal to black DIN terminal) are closed if ID1 is set for DI On/Off.
- The unit is turned on at the keypad.
- The time is within the scheduler "ON" time, if scheduler enabled.
- The BMS has written the unit on signal, if BMS control is enabled.



Upon starting, the isolation dampers will open. The end switches of these dampers will complete the Fan Enable signal to the ECM or VFD fans.

Once the fan enable signal is complete, the fan command signal will be sent to the fan after the start up delay time. Each fan is paired with a current sensor. If within the alarm delay time, default 90s, the current sensor does not detect the fan running, the unit will shut down and an alarm will occur.

The alarm setting *SF Alarm Unit Run?* setting tells whether the unit, and thus the exhaust fan, will continue to run if there is an alarm with the supply fan.

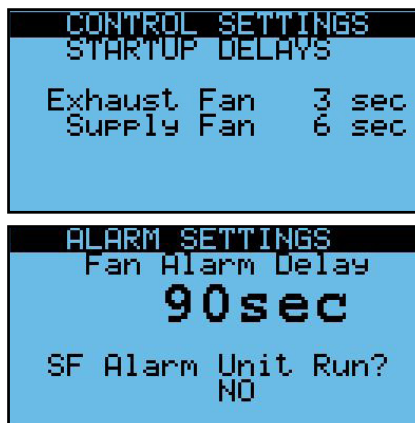

The Unit status is shown on the bottom of this screen. More than one of these statuses may be valid at one time.

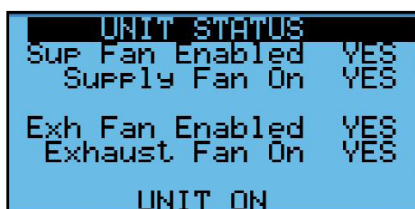

UNIT STATUS CONDITIONS	
STATUS SHOWN	MEANING
Unit on	Unit is on in normal operation.
Off by alarm	Unit is off by alarm condition.
Off by BMS	Unit is off by BMS command (and BMS control is enabled).
Off by DI	Unit is off by digital input ID1.
Off by Keyboard	Unit is off by the switch through the menu screens.
EF Only Mode	Unit is in exhaust fan only mode by either ID2 or BMS.
SF Only Mode	Unit is in supply fan only mode by either ID2 or BMS.
In Device Test	Unit is in Device Test Mode.
Input Overwritten	An input is overwritten in the Sensor Overrides section.
Flush Mode	Unit is in flush mode by scheduler.
Frost Control On	Frost Control mode is on.
In Boost Mode	Unit is in Boost mode by digital input.
Smoke Purge	Unit is in Smoke Purge mode by digital input.
Econ Active	Economizer Bypass is Active.
EF Only Low Temp	Exhaust fan only by low temp (Low SA settings).

5.1.1 Digital Input (ID1) Unit On/Off

The digital input ID1 must be connected to COM to turn the unit on. The orange factory jumper can be left in place if this feature is not used. Some of the uses are a remote switch, a smoke detector, or a motion/occupancy sensor. Shown are the accessories are offered by RenewAire.

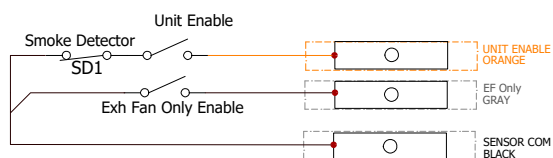

To use the unit enable input or smoke detector remove the orange factory jumper

5.1.1.1 Optional Smoke Detector

Normally field-installed on the discharge duct, near the furnace.

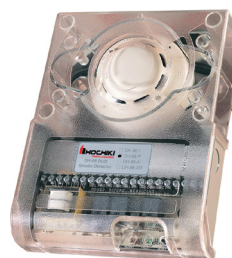

FIGURE 5.1.0 SMOKE DETECTOR

**NOTE:** Some units use ID1 as the door kill switch. Consult your unit's wiring diagram.

**NOTE:** ID1 can be used for alternate functions, set in the I/O Configuration.

5.1.1.2 Optional Motion Sensor

Used for occupancy-based ventilation, hardwired to the low-voltage terminal strip.



FIGURE 5.1.1 MOTION SENSOR (CEILING MOUNT)



FIGURE 5.1.2 MOTION SENSOR (WALL MOUNT)

5.1.2 Isolation Dampers

The ERV unit has optional isolation dampers with end switches. For more information consult the unit specific IOM.

5.1.3 Fans

The variable speed fans may be driven by VFDs or may be ECM fans. The VFD fans get an enable signal and both types of fans get a 0–10VDC signal which is proportional to 0–100% fan command.

Factory VFD settings should not be changed. The settings are available in the *Reference* section of this manual.

**5.2 OPTIONS FOR SUPPLY FAN CONTROL**

Units with a VFD or ECM for the supply fan can control the fan for constant speed.

5.2.1 Constant Fan Speed Option

The analog voltage command to the supply fan VFD or ECM can be set from the unit controller display or by the BMS. The adjustable range of 0% to 100% correspond to the minimum and maximum fan operating speed.

 **NOTE:** It is possible to have the BMS control the fan directly. Refer to the BMS section for more information.



This supply fan operation mode can be used to field balance the SA flow rate.

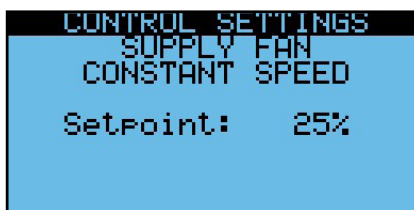



NOTE: It is possible to have the BMS control the fan directly. Refer to the BMS section for more information.

### 5.3 OPTIONS FOR EXHAUST FAN CONTROL

Units with a VFD or ECM for the exhaust fan can control the fan for fixed speed, or supply fan command tracking control.

#### 5.3.1 Constant Fan Speed Option

The analog voltage command to the exhaust fan VFD or ECM can be set from the unit controller display or by the BMS.

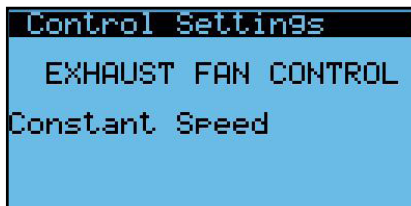

The adjustable range of 0% to 100% correspond to the minimum and maximum fan operating speed. This exhaust fan operation mode can be used to field balance the EA flow rate.



If using boost input, this screen will also appear prompting you to select a command for Boost Mode.

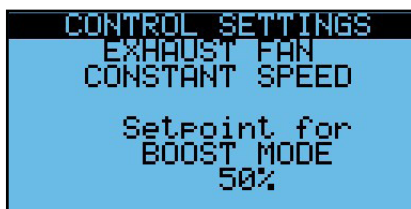

#### 5.3.2 Supply Fan Command Tracking Control Option

The controller will adjust the exhaust fan VFD or ECM command to track the supply fan VFD or ECM command.



The minimum (50%) and maximum (200%) tracking rates are adjustable. This exhaust fan operation mode can be used to maintain proportional supply and exhaust fan commands as the supply fan modulates.

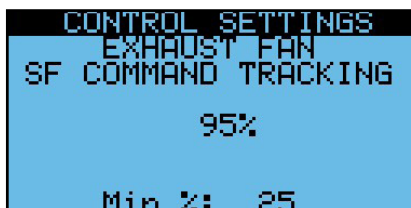

## 6.0 SPECIAL FEATURES

These features are not common but are available in the controller.

## 6.1 FROST CONTROL

This function is usually used in northern states and Canada. To enable the frost control functionality for these units the Enable Frost Cntl must be set to YES in the *Unit Configuration* (password protected) screen.



In the Control Settings you will be prompted to select a Frost Control Type. The two choices are OA Temp setpoint, where the OA Temp when Frost Control starts is entered manually, and RA Dewpoint Offset, where the controller chooses the OA temperature based on the RA dewpoint. The latter should not be used if the RA is not at least 70°F or if the flows are more than 90% unbalanced. This setting will most always save energy in situations where there is no active humidification.

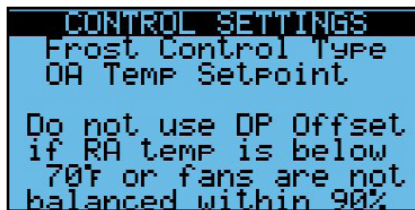

For ERV units, the frost control function disables the supply fan and closes the OA damper when the following conditions are met:

- The OA temperature is less than the OA Below setpoint
- The EA temperature (sensed at the inlet to the EA fan—average exhaust air temperature) is below the EA Below setpoint.

It will turn back off when the EA Above setpoint is reached provided the minimum frost control time (prevents over-cycling).



For variable speed fans, an additional setting is required for the exhaust fan operation. While the supply fan is off, a variable speed exhaust fan (ECM or VFD) will operate at the command set by the FC Exh Command setpoint. This command allows the user to minimize the negative space pressure that will be generated with the EF on and the SF off during frost control. For fans that are not variable speed, the exhaust fan will run at the normal speed and this setting will not be shown.

The frost control mode ends (OA damper is opened and the supply fan is enabled) when the EA temperature increases to the EA Above setpoint. The unit then resumes the selected normal operating mode. If the EA temperature then falls below the OA Below setpoint frost control mode is enabled again. There is a Unit Status screen that will appear if frost control function is enabled.

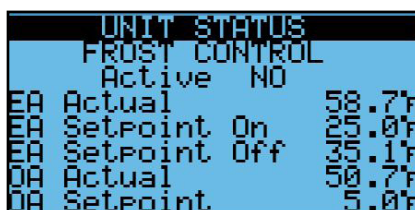

### 6.2 SINGLE FAN MODE

In some cases the application may require that only one fan run. The single fan mode is initiated by either closing the ID2 contact (grey DIN terminal connected to COM) or a BMS command to BMSEFOnly variable. It is BV11 for BACnet and Coil 1 for Modbus, where 0 = No and 1 = Yes. The default is Exhaust Fan but it can be changed to Supply Fan here. If tracking the supply fan, also set a value for exhaust fan in single fan mode.

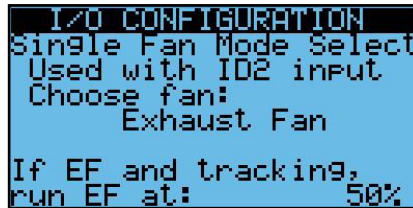

### 6.3 USE ROOM TEMP AND HUMIDITY RATHER THAN RETURN

The system allows you to use a room temperature and humidity sensor in place of the return air temperature and humidity sensor. One use for this is when you have unoccupied operation when the fans are off, you will be able to get a temperature indicative of the actual room temperature. This feature is useful when feeding a single zone. It requires the removal of the return sensors and replacing them with the room sensor. The setting here will change the word “return” to “room” on the main screen to eliminate confusion.

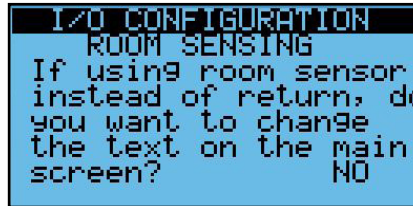

The Room Temperature and Humidity Sensor is P/N 102397 Wall Mount, RTH-W.

### 6.4 FLUSH FEATURE

The flush feature is used in conjunction with the scheduler function that allows you to set the unit into flush mode for specific time periods where the exhaust fan and supply fan will run at a specified CFM or % during this period.

It is enabled in the *I/O Configuration* screen.

 NOTE: Only % is allowed with Enhanced Controls.



The screen to allow you to define how the fans will run while in flush mode.



Once these settings are done, you will now have a third type of mode for the scheduler called FLUSH, as shown. In this example the unit will go into flush mode at 6:45 until 7:00 when it will turn on and run normally. During flush mode the OA and RA dampers (if included) will be open as in normal operation.

```

DAILY EVENTS
Day: Monday
Copy to: MON Ok? No
1 06:45 FLUSH
2 07:00 ON-
3 17:00 OFF
4 --:-- ---
Save data? Yes

```

## 6.5 COLD WEATHER OPERATION

The ERV has a built-in feature for detecting low temperatures to avoid dumping cold air into the space. The settings are shown in the following screen.

```

ALARM SETTINGS
SA Low Temp Warning
  Lower Limit -22.0°F
  Delay Time 30 sec
SA Low Temp Alarm
  Lower Limit -22.0°F
  Delay Time 30 sec

```

Be sure to make sure these settings are appropriate for your application.

- If the SA Temperature falls below the low warning temperature for the delay time while the supply fan is running, the warning will sound but the unit will remain running.
- If the SA Temperature falls below the low alarm temperature for the delay time while the supply fan is running, the alarm will sound but the unit will shut down and require a manual reset to start again.

In versions 4.00.xx and higher, a new setting was added. This function uses the warning levels to shut the unit down. It will then start the unit every duration timeframe to see if the SA conditions have improved. During this time, the unit will either turn the unit off (with warning notification) or run the exhaust fan only at a specific speed.

This feature was added to avoid having to continually reset the low temp alarm in cold periods as the alarm is a manually reset alarm.

The exhaust fan operation is designed for convenience stores, for example, where they may want to continually run a bathroom fan at a lower speed during these times.

```

ALARM SETTINGS
SA Low Temp Warning
Operation
Do Nothing

```

```

ALARM SETTINGS
SA Low Temp Warning
Operation
Turn Unit Off
Duration: 60min

```

```

ALARM SETTINGS
SA Low Temp Warning
Operation
Exhaust Only
Duration: 60min
EF Speed: 50%

```

### 6.6 ECONOMIZER CONTROL (BYPASS/FREE COOLING)

All units that are equipped with a bypass damper allow the incoming air to bypass the enthalpic plate when outdoor air conditions are more favorable. ERV units have two-position bypass

The standard economizer settings are:

- Disabled (No economizing)
- Temperature Diff—looks at the difference of RA and OA Temperature
- Enthalpy Diff—looks at the difference of RA and OA Enthalpy

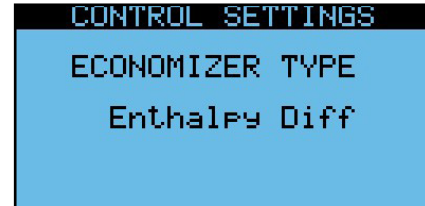
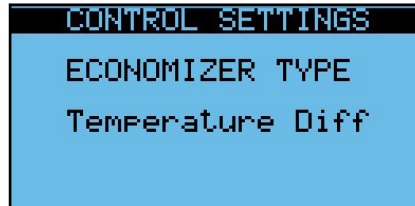

Two additional types are available, if required by specification, by unlocking those in the *Advanced Services* section.

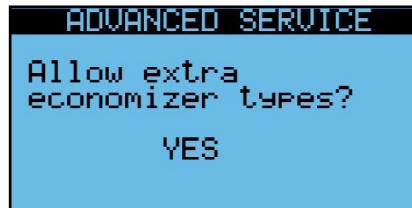

With that setting as YES, you will see these two additional options:

- OA Temp Limits—looks at the fixed OA Temperature
- OA Enth Limits—looks at the fixed OA Enthalpy and OA Temperature

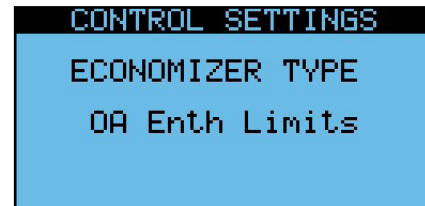
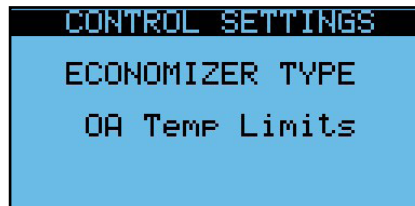

For your convenience, we have provided the ASHRAE 90.1-2019 and Title 24-2019 specifications in the tables on the next page.

ASHRAE90.1-2019 SPECIFICATIONS		
ECONOMIZER TYPE	ALLOWED ASHRAE CLIMATE ZONE	REQUIRED HIGH LIMIT (ECONOMIZER OFF)
Fixed Dry Bulb	1b, 2b, 3b, 3c, 4b, 4c, 5b, 5c, 6b, 7, 8	TOA>75F (24C)
	5a, 6a	TOA>70F (21C)
	1a, 2a, 3a, 4a	TOA>65F (18C)
Differential Dry Bulb	1b, 2b, 3b, 3c, 4b, 4c, 5a,5b, 5c, 6a, 6b, 7, 8	TOA>TRA
Fixed Enthalpy + Fixed Dry Bulb	All	hOA>28 Btu/lb(66 kJ/kg) or TOA>75F(24C)
Differential Enthalpy + Fixed Dry Bulb	All	hOA>hRA, TOA>75F (24C)

TITLE 24-2019 SPECIFICATIONS		
ECONOMIZER TYPE	CALIFORNIA CLIMATE ZONE	REQUIRED HIGH LIMIT (ECONOMIZER OFF)
Fixed Dry Bulb	1, 3, 5, 11-16	TOA>75F (24C)
	2, 4, 10	TOA>73F (23C)
	6, 8, 9	TOA>71F (22C)
	7	TOA>69F (21C)
Differential Dry Bulb	1, 3, 5, 11-16	TOA>TRA
	2, 4, 10	TOA>TRA-2F(1C)
	6, 8, 9	TOA>TRA-4F(2C)
	7	TOA>TRA-6F(3C)
Fixed Enthalpy + Fixed Dry Bulb	All	hOA>28 Btu/lb(66 kJ/kg) or TOA>75F(24C)

6.6.1 Economizer Based on Temperature Difference Sequence

When the OA temperature is below the RA temperature less the hysteresis value, the economizer will bypass the core with incoming air. The economizer will be locked out when any of these it true:

- The OA temperature is less than the OA Temp Lockout
- The RA temperature is below the RA Temp Lockout
- Tempering mode is Heating (see Heating OA Lockout)

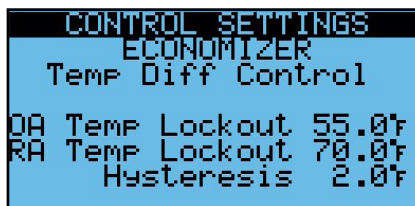

### 6.6.2 Economizer based on Enthalpy Difference Sequence

When the OA enthalpy is below the RA enthalpy less the hysteresis value, the economizer will bypass the core with incoming air. The economizer will be locked out when any of these it true:

- The OA temperature is less than the OA Temp Lockout
- The RA temperature is below the RA Temp Lockout
- Tempering mode is Heating (see Heating OA Lockout)

```
CONTROL SETTINGS
ECONOMIZER
Enthalpy Diff Control
OA Temp Lockout 55.0°F
RA Temp Lockout 70.0°F
Hysteresis 1.0btu/lb
```

### 6.6.3 Economizer Based on OA Temperature Limits

The economizer will bypass the core with incoming air when OA is favorable. The economizer will be locked out when any of these it true:

- The OA temperature is less than the OA Temp Low Lim
- The OA Temp is above the Hi Lim
- Tempering mode is Heating (see Heating OA Lockout)

```
CONTROL SETTINGS
ECONOMIZER
OA Temp Limits
OA Temp Low Lim 55.0°F
OA Temp Hi Lim 70.0°F
```

### 6.6.4 Economizer Based on OA Enthalpy Limits

The economizer will bypass the core with incoming air when OA is favorable. The economizer will be locked out when any of these it true:

- The OA enthalpy is greater than the OA Enth Lim
- The OA Temp is above the Hi Lim
- The OA Temp is below the Low Lim
- Tempering mode is Heating (See Heating OA Lockout)

```
CONTROL SETTINGS
ECONOMIZER
OA Enth Limit
OA Enth Lim 66btu/lb
OA Temp Hi Lim 55.0°F
OA Temp Low Lim 70.0°F
```

## 6.7 SMOKE OR FREEZESTAT DEDICATED INPUT

It is possible to dedicate either digital input for a smoke and/or freezestat alarm which will shut down the unit and issue a manual reset alarm when engaged.

To use this feature, go to the I/O Configuration area and view this screen. The default for ID1 is DI On/Off and the default for ID2 is Single Fan Mode.

```

I/O CONFIGURATION
DI9 Inputs Used For
ID1:DI On/Off
ID2:Single Fan Mode
Must be different!
  
```

Change the input(s) to your desired alarms. Make sure you do not duplicate them. Shown is a sample but either input can be used for either alarm.

```

I/O CONFIGURATION
DI9 Inputs Used For
ID1:Freezestat
ID2:Smoke Alarm
Must be different!
  
```

Once you do that, you will see either of these screens show up accordingly. Make sure you set the action for either *Open is ON* or *Open is Off*.

```

I/O CONFIGURATION
Smoke Alarm
Action
Open is OFF
  
```

```

I/O CONFIGURATION
Freezestat Alarm
Action
Open is OFF
Alarm only if on? NO
Delay from on: 0s
  
```

You will also have the additional manual reset alarm(s) according to your selection:

- AL08: Smoke Alarm
- AL09: Freezestat Alarm

## 6.8 BOOST MODE

This feature was added in version 03.00.45.

This feature allows the user to designate an unused digital input (ID1 or ID2) as a boost input that will boost an ERV running in constant speed or constant flow mode to a “boost” level set in the screen or through BACnet.

In order to enable the feature, assign Boost Mode to one of the inputs in the *I/O Configuration*.

```

I/O CONFIGURATION
D19 Inputs Used For
ID1:Boost Mode
ID2:Sing Fan Mode
Must be different!
  
```

In the *Control Settings*, you will now see that you have two extra screens that appear for Supply and Exhaust Fan settings provided you have set the fans for constant speed control or flow control.

If the supply fan is set for flow control, for example, and the exhaust fan is set for tracking, the exhaust fan will track the boosted supply fan automatically.

This feature is not available for fans controlled by pressure or CO2 levels.

```

CONTROL SETTINGS
SUPPLY FAN
CONSTANT SPEED

Setpoint for
BOOST MODE
50%
  
```

```

CONTROL SETTINGS
EXHAUST FAN
CONSTANT SPEED

Setpoint for
BOOST MODE
50%
  
```

## 6.9 SMOKE PURGE

This feature can be used with a fire switch to purge the space after a smoke incident has occurred. It utilizes one of the digital inputs.

```

I/O CONFIGURATION
D19 Inputs Used For
ID1: DI On/Off
ID2: Smoke Purge
Must be different!
  
```

The action can be set for Open is OFF or Open is On. If on, the unit will run the supply and exhaust fans according to the settings shown during that period. This will occur whether the unit is off or on.

```

I/O CONFIGURATION
Smoke Purge
Action: Open is OFF

Enable SF?      NO
SF Purge %:    80%
Enable EF?      NO
EF Purge %:    80%
  
```

## 6.10 SWAP AIRFLOWS

For ERVs without bypass, if you need to swap the OA and RA airflow, the controller will accommodate that without any rewiring. You can do this on this screen in the *Advanced Services* section.

```

ADVANCED SERVICE
Swap OA and RA Airflow
Swapped

Not available for
units with bypass.
If swapped, change
labels accordingly.
  
```

You will now see they are swapped in the *Unit Status* screen with the version information. Be sure to change the labels in the unit. You can request new labels through TSS.

```

UNIT STATUS

*RenewAire ERV/DOAS*
Code:USRNAeERVN
Swapped
SW ver.: 4.0.009
OS ver.: 0.0.000
          aaaaaaaaaaaaaaaaaa
  
```

## 6.11 UNIT ON/OFF OUTPUT

If you require an additional component such as a damper or fan to turn on and off according to the unit condition it is possible to use the alarm output NO6 to do this. The output has both normally open and normally closed contacts. If you have frost control enabled it will also ask if you want that condition to be considered as unit off.

```

I/O CONFIGURATION
NO6 Functionality
Ctrl: Unit On
  
```

```

I/O CONFIGURATION
NO6 Functionality
Ctrl: Unit On

Consider SA Off by
Frost Control as Unit
Off?      YES
  
```

### 7.0 VERIFYING I/O AND UNIT WIRING

All of the I/O values should be verified and calibrated, if necessary.

#### 7.1 VERIFYING ALL I/O THROUGH UNIT STATUS SCREENS

All of the individual I/O are able to be viewed in one place by pressing “ENTER” when on this screen, which is located toward the end of *Unit Status*.



There will be individual screens for each input and output. Several examples are shown.

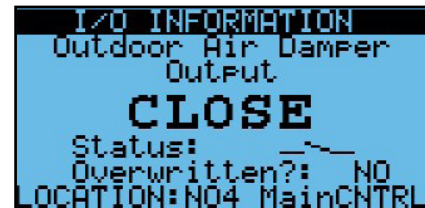
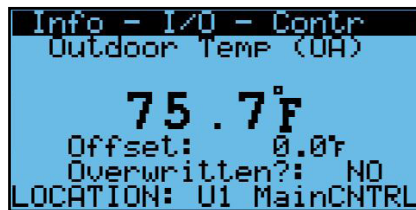

#### 7.2 CALIBRATING I/O

For a temperature sensor that may have run a long distance or a humidity sensor with a reading that may have drifted over time, a calibration may be necessary. There is a screen such as the one shown for each sensor and transducer. The current value at the top will reflect the change with the offset that is set in this screen.



#### 7.3 GENERAL UNIT CONTROL WIRING

The following tables and diagrams show the general unit control wiring for the ERV units. A unit-specific electrical schematic is found inside the access door to the core module.

## 7.3.1 Sensor Inputs

SENSOR	TYPE	SENSOR TERMINALS	CONTROLLER TERMINALS
OA Temperature	Tasseron NTC and 0–10VDC	T Far Left (Brown)	U1 (Main)
OA Humidity		T 2 (Black)	Black DIN
		+ 3 (Red)	Red DIN
		- 4 (Black)	Black DIN
		0 5 (Green)	U2 (Main)
RA Temperature	Tasseron NTC and 0–10VDC	T Far Left (Red)	U3 (Main)
RA Humidity		T 2 (Black)	Black DIN
		+ 3 (Red)	Red DIN
		- 4 (Black)	Black DIN
		0 5 (White)	U4 (Main)
SA Temperature	CAREL NTC	(Red or White)	U5 (Main)
		(Black)	GND (Main)
EA Temperature	CAREL NTC	(Red or White)	U6 (Main)
		(Black)	GND (Main)
OA Filter Pressure	0–10VDC	VAC/V+ (Red)	Red DIN
		COM/GND (Black)	Black DIN
		VOUT/OUT (Blue)	U7 (Main)
RA Filter Pressure	0–10VDC	VAC/V+ (Red)	Red DIN
		COM/GND (Black)	Black DIN
		VOUT/OUT (Blue)	U8 (Main)

## 7.3.2 Digital Inputs

Inputs in Grey are optional, and field-installed.

INPUT	TYPE	INPUT TERMINALS	CONTROLLER TERMINALS
Smoke Detector	Dry Contact		Orange DIN
			Black DIN
ID1 Unit Enable (unless designated for other use)*	Dry Contact		Orange DIN
			Black DIN
ID2 Single Fan Mode (unless designated for other use)*	Dry Contact		Gray DIN
			Black DIN
SF Current Switch (SF Status)	Dry Contact	(Black)	GND (Main)
		(Red)	U9 (Main)
EF Current Switch (EF Status)	Dry Contact	(White)	GND (Main)
		(Red)	U10 (Main)

 NOTE: You can dedicate the smoke detector to an input to get a specific smoke alarm. See *Special Features* section.

\* Some units have the doorkill switch wired into this input. Consult the wiring diagram on your unit to verify.

## 7.3.3 Digital Outputs

Outputs in Grey are optional, and field-installed. Dampers could be factory or field-installed.

OUTPUT	TYPE	OUTPUT TERMINALS	CONTROLLER TERMINALS
SF Enable	Dry Contact	(See wiring diagram)	NO1 (Main) C1/2 (main)
EF Enable	Dry Contact	(See wiring diagram)	NO2 (Main) C1/2 (main)
Bypass Damper (if available)	Dry Contact	HOT (Orange)	NO3 (Main)
		COM (Purple)	Accy COM (White)
OA Damper	Dry Contact	HOT (Red)	NO4(Main)
		COM (Black)	Accy COM (White)
RA Damper	Dry Contact	HOT (Red/Brown)	NO5 (Main)
		COM (Black/Purple)	Accy COM (White)
Serious Alarm Output	Dry Contact*		NO6/NC6 (Main)
			C6 (Main)

\*Can also be used to indicate on/off status.

## 7.3.4 Analog Outputs

OUTPUT	TYPE	CONTROLLER TERMINALS
SF Signal	0–10VDC	Y1 (Main)
		GND (Main)
EF Signal	0–10VDC	Y2 (Main)
		GND (Main)

7.3.5 Sample Power Wiring Schematic

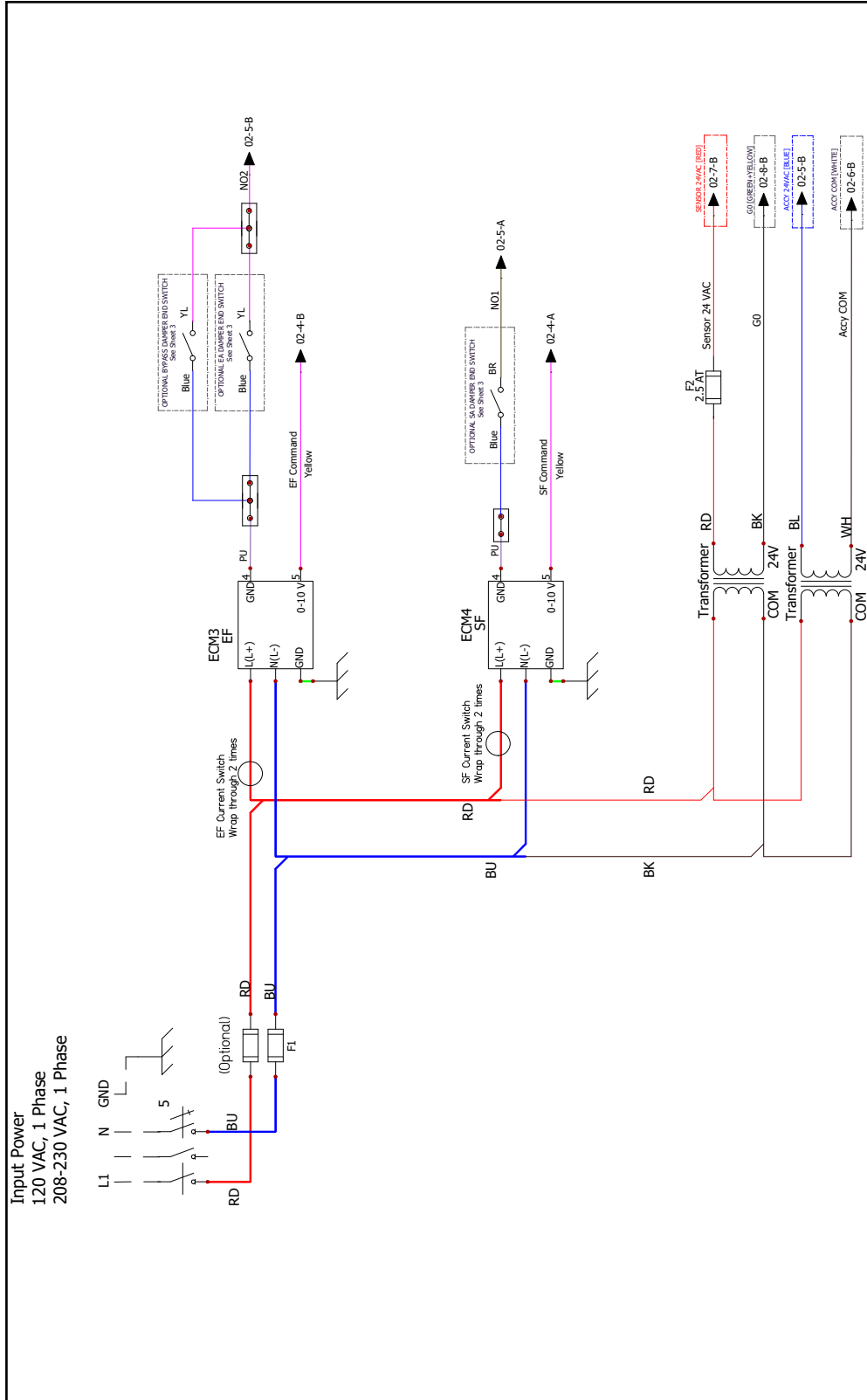

**NOTE:** This wiring schematic is TYPICAL control wiring for a single phase 120VAC or 208-230VAC input for model HE10-. A unit-specific electrical schematic is found inside the access door to the core module.



**NOTE:** This wiring schematic is TYPICAL control wiring. A unit-specific electrical schematic is found inside the access door to the core module.

7.3.6 Sample Control Wiring Schematic

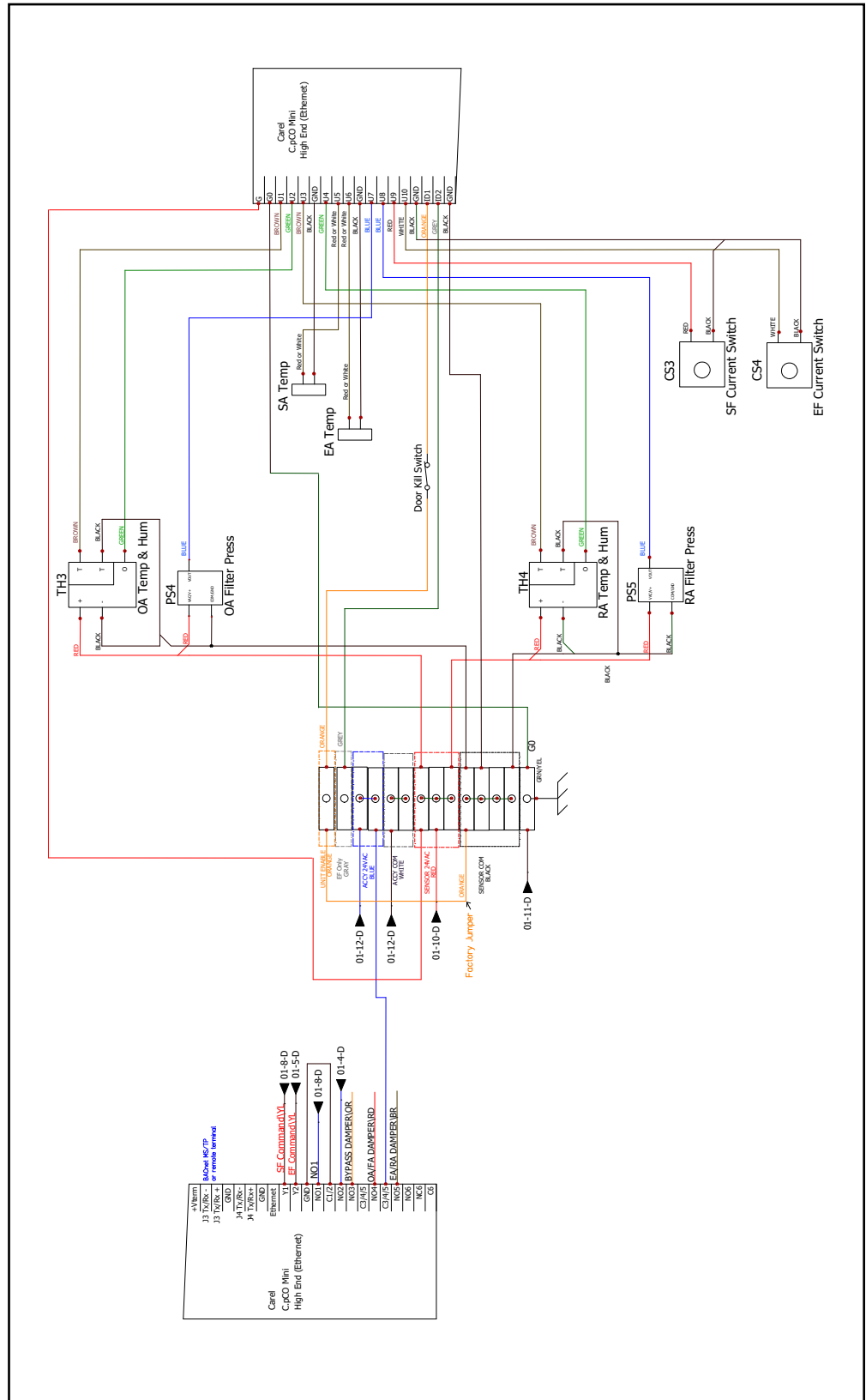

7.3.7 Sample Field Wiring Schematic

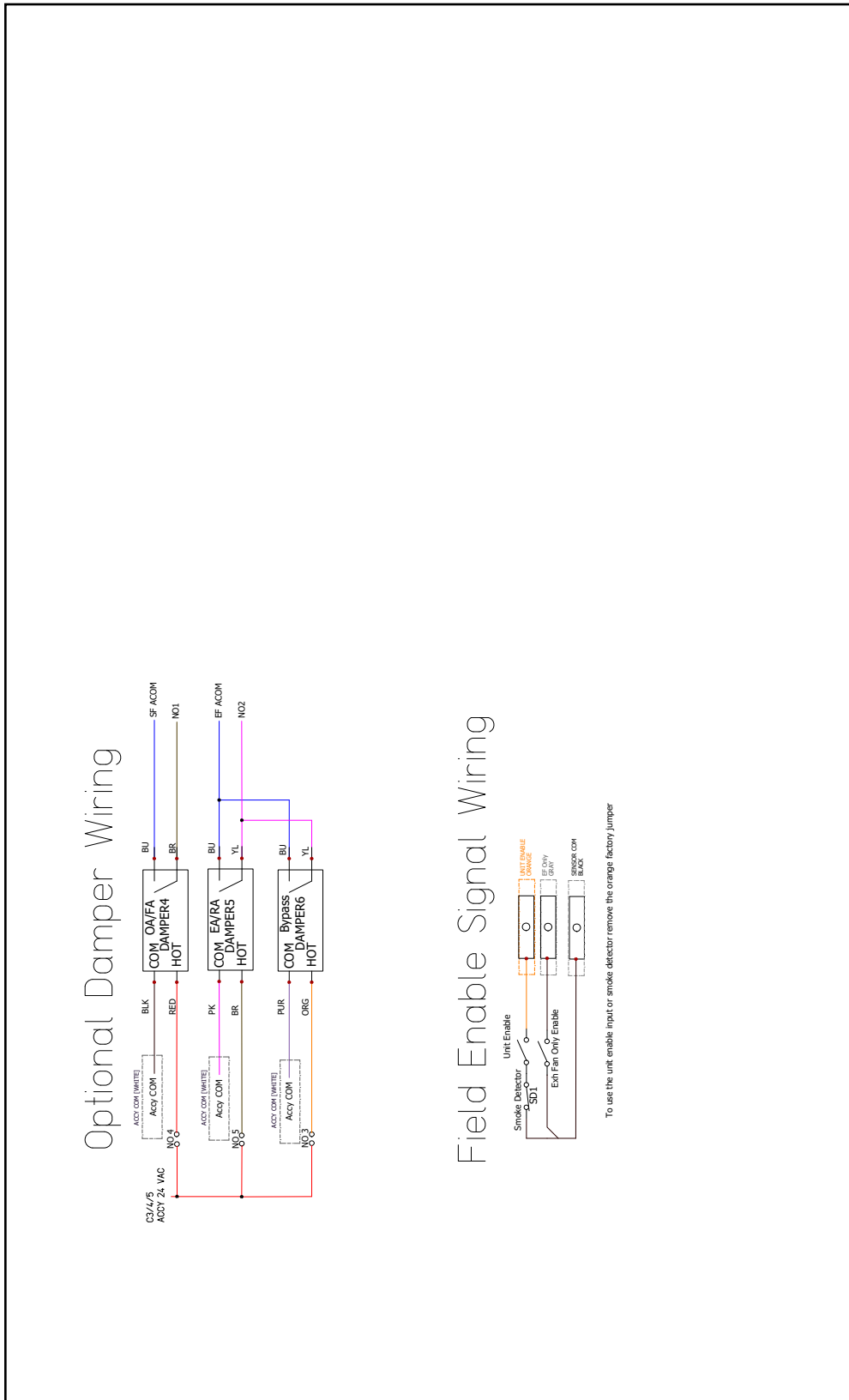

**NOTE:** This wiring schematic is TYPICAL control wiring. A unit-specific electrical schematic is found inside the access door to the core module.

## 8.0 ALARMS AND TROUBLESHOOTING

If the problem is caused by an alarm, the first step in troubleshooting is to view the Alarm screens. Press the Alarm button on the face of the controller to see all current alarms and what function or component is causing the alarm. In some cases, the Alarm pre-set may need to be adjusted or an offset may need to be changed. Before making any changes to the controller programming, be certain to have an updated Backup file so that current settings can be easily restored, if needed. See the following *Alarms* section for these.

Problems with an air handler are sometimes strictly mechanical, in which a fan or damper or some other component simply stops working. Mechanical problems are easily traced to specific components by using the Test End Device feature in the service level. See the following *Test End Devices* section for this.

In other cases, problems may be caused by the air handler trying to overcome a pre-set or operating parameter that has been set by the user. In these cases, view the controller screens to trace the problem. See *Other Common Problems* section for these.

### 8.1 ALARMS

The alarms are viewed through the controller screen or through the BMS.

#### 8.1.1 Acknowledging Alarms

When an alarm occurs, you will hear a buzzer sound and the alarm light will flash. Press the alarm button to acknowledge the alarm and quiet the buzzer.

#### 8.1.2 Viewing Alarms and Alarm Log

If there are active alarms the alarm button will be red. To view the active alarms, press the alarm button. Each alarm has an alarm number (AL\*11, in this case), a time stamp, and a message to show which alarm occurred.

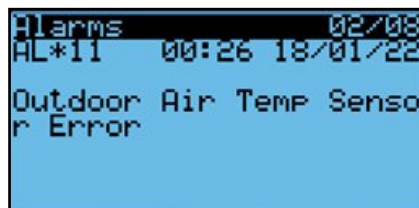

Continue to press the button to cycle through all active alarms. At the end you will see this screen. Here you can press "ENTER" to see the past alarms.



An alarm log screen looks like this. If the event is Stop, it shows the time that the alarm went away. If the event is Start, it shows the time that the alarm first occurred. There may be up to 50 entries.

```

Data logger Record:01
          14:32 14/03/20
Exhaust Air Flow Rate
Sensor Error
Event:      Start
  
```

If no alarms are active, the screen will say No Alarms but you can still press “ENTER” to view the last 50 alarm occurrences.

```

NO ALARMS
Press ENTER
to DATA LOGGER
  
```

### 8.1.3 Resetting Alarms

If you cycle through the alarms, you will see this screen. At this time, you can hold the alarm button down to reset the “User Reset” alarms. (The auto reset alarms reset themselves.)

```

Alarms
Press ALARM for 3s
to reset all alarms
Press ENTER
to DATA LOGGER
  
```

### 8.1.4 Alarm Digital Outputs

The controller includes a digital output for remote indication of an alarm condition.

The first is AlarmOut.val and it closes the contact if there is an alarm that will shut down the unit. These include:

- Low Supply Temperature Alarm
- High Supply Temperature Alarm
- Loss of communication between the controller and the expansion module
- Exhaust Fan Alarm (Failure to start)
- Supply Fan Alarm (Failure to start) ONLY IF the *SF Alarm Unit Run?* is set to No. If yes, the unit will not shut down and the exhaust fan will be allowed to continue to run. All heating and cooling functions will be locked out, however.

```

ALARM SETTINGS
Fan Alarm Delay
          90sec
SF Alarm Unit Run?
          NO
  
```

The second is AnyAlarmOut.val and it closes the contact if there is any alarm including the ones in AlarmOut.val.

The physical connection for the first is made at the controller and the second is made at the expansion module. Both are terminated at the same terminal, J12, located in the upper right corner. There is both a normally open (NO6 to C6) and normally closed (NC6 to C6) option.

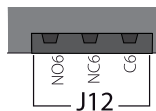

### 8.1.5 Specific Alarms and Their Meaning

The alarms are identified by number. They are grouped by type. Alarms 50–57, alarms 66–68.

#### 8.1.5.1 General Alarms

NUMBER	NAME	STATUS SHOWN	MEANING
0	AI_retain	User reset	Error in the number of retain memory writings
1	AI_Err_retain_write	User reset	Error in retain memory writings
2	AI_Device_Test	Auto reset	Device Test is Running—Outputs Disabled!
3	AI_BMS_Offline	Auto reset	Device offline alarm to BMS
4	OfflineAlrm_CPCOE_1	Auto reset	Device offline alarm CPCOE
5	CfgErrAlrm_CPCOE_1	Auto reset	Wrong configuration on device CPCOE
8	AI_Smoke	User Reset	Smoke Alarm Input is engaged
9	AI_Freeze	User Reset	Freezestat Alarm Input is engaged

**Alarm Number 0:** Error in the number of retain memory writings

This usually means indicates that the BMS is writing to a retained setpoint too often. Retained values are stored in a special memory so that they are kept on power loss. Failure to correct this could result in damage to the controller.

**Alarm Number 1:** Error in retain memory writings

This usually means indicates that the BMS is writing to a retained setpoint too often. Retained values are stored in a special memory so that they are kept on power loss. Failure to correct this could result in damage to the controller.

**Alarm Number 2:** Device Test is Running—Outputs Disabled!

This alarm occurs if someone had the unit in device test mode and the time limit has passed, usually an hour. Either cycle power to the unit or go into the Device Test section in the password protected menus and turn it off.

**Alarm Number 3:** Device offline alarm to BMS

This alarm occurs if the BMS is enabled, and it is offline.

**Alarm Number 4:** Device offline alarm CPCOE

This alarm occurs if the controller and expansion module have lost communication. For correct operation the dipswitches are set (left to right) Forward, backward, forward, backward, forward, forward, forward, forward. This coincides with an address of 5. Sometimes if they have been moved around it is necessary to set them all to OFF (forward), cycle power, and then set them as required, and then cycle power again.

- Check the wiring: FBUS on the controller to BMS on the expansion.
- Check that the dipswitches are positioned correctly.

**Alarm Number 5:** Wrong configuration on device CPCOE

This alarm is an internal alarm. Contact TSS if this alarm occurs.

**Alarm Number 8:** In Special Features, either ID1 or ID2 may be dedicated to a smoke alarm input. This alarm indicated that the alarm is engaged.

**Alarm Number 9:** In Special Features, either ID1 or ID2 may be dedicated to a freezestat alarm input. This alarm indicated that the alarm is engaged.



**NOTE:** The green LED indicates communication status on the BMS port. If there is communication on the BMS port (online) the green LED flashes, if there is no communication (offline) the LED stays on steady.

### 8.1.5.2 Supply and Exhaust Alarms

NUMBER	NAME	STATUS SHOWN	MEANING
10	AI_SupplyFan	User reset	Supply Fan Alarm
11	AI_ExhaustFan	User reset	Exhaust Fan Alarm

#### Alarm Number 10: Supply Fan Alarm

This indicates that either the supply fan did not start, or that the current switch did not register the supply fan as running. Refer to the Supply or Exhaust Fan Alarm Troubleshooting section in the Test End Devices.

The delay for this alarm is set here. The setting is shared with the exhaust fan. Whether the unit shuts down if this alarm occurs is also set here.



#### Alarm Number 11: Exhaust Fan Alarm

This indicates that either the exhaust fan did not start, or that the current switch did not register the exhaust fan as running. Refer to the Supply or Exhaust Fan Alarm Troubleshooting section in the Test End Devices.

The delay for this alarm is set here. The setting is shared with the supply fan. This alarm will shut the unit down.



### 8.1.5.3 Airflow Condition Alarms

NUMBER	NAME	STATUS SHOWN	MEANING
16	AI_SupAir_Low_Temp_Warn	Auto reset	Low SA Temp Warning
17	AI_SupAir_Low_Temp_Alarm	User reset	Low SA Temp Shutdown

#### Alarm Numbers 16 and 17: Low SA Temp Warning and Low SA Temp Shutdown

In units without heating, the alarm applies to the supply temperature (SA). In units with heating, this alarm applies to the unit supply temperature that is measured after the heating unit.

First, view the sensor value in *Unit Status*. If it seems OK, then check the alarm levels set here. The difference in the two is that the warning will just show as an alarm while the shutdown will shut down the unit. You can use the warning as a warning set at higher temperature for the purposes of warning. You can also just use one or the other by setting the limits of the one you do not want to use very low.

```

ALARM SETTINGS
SA Low Temp Warning
Lower Limit -22.0°F
Delay Time 30 sec

SA Low Temp Alarm
Lower Limit -22.0°F
Delay Time 30 sec

```

## 8.1.5.4 Sensor Alarms

NUMBER	NAME	STATUS SHOWN	MEANING
28	AI_SA_Hum_Prpb	Auto reset	SA Humidity Transducer Error
29	AI_EA_Hum_Prpb	Auto reset	EA Humidity Transducer Error
30	AI_OA_Temp_Prpb	Auto reset	OA Temperature Sensor Error
31	AI_OA_Hum_Prpb	Auto reset	OA Humidity Transducer Error
32	AI_RA_Temp_Prpb	Auto reset	RA Temperature Sensor Error
33	AI_RA_Hum_Prpb	Auto reset	RA Humidity Transducer Error
34	AI_SA_Temp_Prpb	Auto reset	SA Temperature Sensor Error
35	AI_EA_Temp_Prpb	Auto reset	EA Temperature Sensor Error
36	AI_OA_Flt_Press_Prpb	Auto reset	OA Filter Pressure Transducer Alarm
37	AI_RA_Flt_Press_Prpb	Auto reset	RA Filter Pressure Transducer Alarm

**Alarm Numbers 28–37:** Sensor Alarms

These alarms occur when the controller detects that sensor is not reading in the expected range. Passive sensors such as temperature sensors show an error when the controller detects a short circuit or open circuit. Active sensors (0–10V) are in alarm when they value read is slightly above 10V.

To resolve the alarms, check the wiring to see if there is a loose wire or missing sensor.

## 8.1.5.5 Filter Alarms

NUMBER	NAME	STATUS SHOWN	MEANING
60	AI_OA_Flt_Press	Auto reset	OA Filter Pressure Alarm
61	AI_RA_Flt_Press	Auto reset	RA Filter Pressure Alarm

**Alarm Numbers 60–61:** Filter Alarms

These alarms occur when the pressure exceeds the OA Level or the RA Level as set in the *Alarm Settings*.

For more information refer to Pressure Drop Charts in the unit specific IOM.

```

ALARM SETTINGS
Filter Alarms

OA Level 1.0"wg
RA Level 1.0"wg
Alarm Delay 60 sec

```

To resolve the alarms, change the filter. If the alarm is still active, verify that the reading is as expected in the *Unit Status*. If not, check that someone has not changed the pressure transducer range in the *I/O Configuration*. Also check the offset or override for the sensors.

#### 8.1.5.6 Maintenance Alarms

NUMBER	NAME	STATUS SHOWN	MEANING
62	AI_UnitLife	Auto reset	Unit Service Threshold Reached
64	AI_SupplyFanLife	Auto reset	Supply Fan Service Threshold Reached
65	AI_ExhaustFanLife	Auto reset	Exhaust Fan Service Threshold Reached

#### Alarm Numbers 62–65: Maintenance Alarms

These alarms occur when the number of run hours reaches the thresholds set in the *Advanced Service*. A typical screen is shown here.

```

ADVANCED SERVICE
UNIT SERVICE INFO
Run Hours:      0
Svc Thr:       200000hr
STATUS:OK
Reset Svc Hrs: NO
Starts:        0
Reset Starts:  NO
  
```

Refer to the *Advanced Service* for more information on these settings.

## 8.2 TEST END DEVICES

The *Test End Devices* allows you to manually control outputs for testing. The unit must be off for this feature to be enabled. An alarm will occur in one hour (default) if you forget to take the device out of test mode.

Once done. Make sure you cycle power to end test mode and put all values back to zero.

```

TEST END DEVICES
ENABLE DEVICE
TEST MODE:
Disable
Max Time: 3600s
  
```

### 8.2.1 Supply or Exhaust Fan Alarm Troubleshooting

These alarms, 10 and 11, mean that either the fan did not start or that the current switch did not detect that the fan is running. To troubleshoot this:

- Turn the unit off through the keypad.
- In the password protected menus, go to the *Test End Devices* and enable. As shown, an alarm will sound if you leave the unit in device test mode for more than an hour (default).

```

TEST END DEVICES
ENABLE DEVICE
TEST MODE:
Enable
Max Time: 3600s
  
```

- Open both dampers.



- Enable both fans.



- For the fan that has the alarm (supply or exhaust), command the fan to run at 35% or so. If you don't see the feedback (current switch) to yes, then the problem is with the current switch. If the fan starts but you don't see the feedback, the problem is with the current switch.
- If you think the problem is with the current switch, try adjusting the fan % up until you see the feedback go to YES. During this time, you should also see the flow to continue to increase. Once you see the feedback turn to yes you know the current switch needs adjustment. If it gets to 100% and you do not see it turn to yes, it may be wiring or a bad current switch. You can try to adjust it below.

#### Adjusting the Current Switch

With the dampers open and the fans enabled as described in the Test End Devices mode above, set the fan for which you want to calibrate to the minimum speed (%) at which you expect it to operate.

On the top of the sensor, there are an adjusting screw and two LED lights, one red and one blue. The adjusting screw will turn 15 turns. To set the sensor for any fixed-speed fan:

- Verify that the blue LED is on.
- Slowly adjust the potentiometer screw clockwise until the RED LED just turns on. This sets the trip point at the normal operating load current
- If the RED LED is on after initial power-up, slowly adjust the potentiometer counter-clockwise until the BLUE LED turns on and then slowly adjust the potentiometer clockwise until the RED LED just turns on.

### IMPORTANT

Cycle power to the unit after you are done testing. This will take the unit out of Device Test Mode and reset all of the test values to off or 0%.

## 8.3 OTHER COMMON PROBLEMS

Listed are some other common problems you may encounter.

### 8.3.1 Unit Not On

If the unit will not run, go to this screen in *Unit Status* and the bottom line will tell you why.

Multiple items may be true. Possible messages and their meaning:

- Unit On: Unit is running
- Off by Alarm: A serious alarm is present; usually a fan alarm or supply temp alarm.
- Off by BMS: The BMS has set Enable BMS Control to yes and is not sending an On command.
- Off by DI: The orange DIN terminal must be connected to the black din terminal.
- Off by Keyboard: The menu screen *Unit On/Off* is set to off.
- Exhaust Fan Only Mode: The gray DIN terminal is connected to the black terminal indicating single fan mode. The setting for which fan will run is in *I/O Configuration*.
- Supply Fan Only Mode: The gray DIN terminal is connected to the black terminal indicating single fan mode. The setting for which fan will run is in *I/O Configuration*.
- In Device Test: Mode in *Test End Devices* is enabled. Cycle power to get it out of this mode.
- Input Overwritten: There is a sensor that is overwritten in Sensor Overrides. This occurs after 24 hours as a reminder.



### 8.3.2 Sensor Reading #### or Has Extreme Value

This normally means that the sensor is not connected, or it has faulty wiring.

### 8.3.3 BMS Loss of Comm after Param Change or Restore

Most BMS setting changes require a power cycle. This applies to a parameter restore, which is basically the same thing.

### 8.3.4 Can Not See Device via IP Connection

If you are connected locally with a PC:

- Make sure your PC is on the same subnet but not the exact same IP address. The last octet has to differ.
- If you have just changed the IP address, make sure you said “update” on that screen and cycle power.
- Make sure the cable “snaps in” on both sides.
- Microsoft Edge browser does not work as well. Use Chrome, if possible.
- Make sure you don’t have anything in the USB connection in the front of the controller.

If you are connected remotely, check all of the above but also note that the connection has to be on the same subnet. An IP tunnel may also work.

## 8.4 TESTING FUNCTIONS IN GENERAL

When testing in general, the Sensor Overrides is a handy tool. These allow you to temporarily override a sensor to see if a function is working correctly. For example, if you want to test your cooling but it is cool outside, you can override your outdoor sensor to exceed the cool lockout temperature. This is handier than having to change all of your settings and then set them back.

To override a sensor, first set the value of the sensor and then enable. If you enable before setting the value, the value shown will be set right away. In this case, it will most likely turn on your heat.

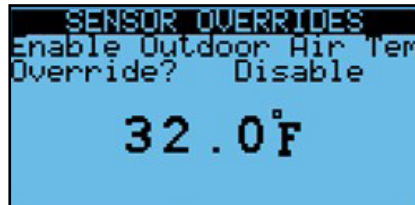

If you leave a sensor overwritten, an alarm will occur after 24 hours. All overwritten values are lost on power cycle and the statuses go back to disabled.

## 8.5 RESTORE PARAMETERS (SETTING)

There are several levels of settings in the controller. Some are set by the factory, and some are set by users. These parameters include all configuration settings, fan settings, heat/cool settings, and BMS settings.



**NOTE:** RenewAire highly recommends that a USB thumb drive be installed in the USB port and a system backup (external) be made immediately after start up or commissioning.

### 8.5.1 User Commissioning Settings (Service)

At the end of the I/O Configuration, the user is prompted to save their settings. It is probably best to save these values after setting all of the values in the Control Variables as well. This is password protected as every time you save the settings, the file will overwrite. The file name is "SERVICE.txt," and it will be saved to either the internal memory location, or the external USB drive that is attached in front.

To perform this operation, the unit must be OFF.

- Choose the location: internal or USB
- Set Confirm to YES

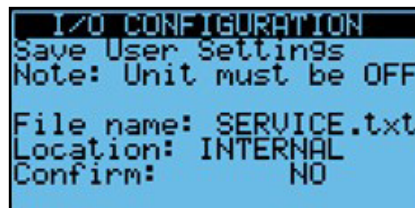

If you choose USB and you get "Cannot access disk," there is something wrong with the connection or disk.



If you do the operation correctly, it will say “Operation Done.”

```

I/O CONFIGURATION
Save User Settings
Note: Unit must be OFF
File name: SERVICE.txt
Location: INTERNAL
Confirm:      YES
Operation done
  
```

To restore user settings, the screen is in Backup and Restore. The steps are:

- Choose the location: internal or USB
- Set Confirm to Yes

You should see “Operation done.”

```

BACKUP & RESTORE
Restore User Settings
Note: Unit must be OFF
File name: SERVICE.txt
Location: INTERNAL
Confirm:      NO
  
```

If the unit does not confirm that the operation was done, the controller may have been older and upgraded in the field. Older version saved factory parameters in EXPORT\_76. See the *General Save and Restore* for information on how to get those settings back into the controller.

### 8.5.2 Restore Factory Settings

This operation is used to go back to factory settings that were set in the factory while they tested the unit. These are somewhat specific settings but going back to these settings will require you to perform start up and commissioning again. To return to factory defaults:

- Choose internal
- Set Confirm to YES

```

S BACKUP & RESTORE
Restore Factory
Note: Unit must be OFF
File name: FACTORY.txt
Location: INTERNAL
Confirm:      NO
  
```

If the unit does not confirm that the operation was done, the controller may have been older and upgraded in the field. Older version saved factory parameters in EXPORT\_76. See the *General Save and Restore* for information on how to get those settings back into the controller.

### 8.5.3 General Save and Restore

There is a general save and restore function that allows you to save different versions of your parameters and save them under slightly different names.

Both saving and restoring use the same screen so care should be taken to make sure you have the screen set correctly so you do not lose all of your settings.

- Choose IMPORT (for restoring) or EXPORT (for saving)
- Choose memory type: INTERNAL or USB

- If the unit does not confirm that the operation was done, the controller may have been older and
- Choose File ID: EXPORT\_xx, where xx is any number from 00 to 99, If you are saving a set of parameters remember the number.
  - Set Confirm to YES

```

S  BACKUP & RESTORE
Params Import/Export
Import/Export:
EXPORT
Memory type:
INTERNAL FLASH MEMORY
File ID:      EXPORT_00
Confirm:      NO
    
```

8.5.4 Code List for Save and Restore

Use these codes to troubleshoot the Save and Restore Feature.

MESSAGE	MEANING
Operation Done	Save or Restore was successful.
Cannot Access Disk	This usually happens when you choose USB and the USB is not inserted or detected. If inserted, the connector may be too short.
Cannot access file	This usually happens when you are importing and the file you are importing does not exist.
Memory buffer is too small	You may have to erase some data from the drive or USB before you can perform the operation.
Time parameters are not correct	The clock needs to be set in <i>General Settings</i> .
Module is currently busy—retry is required	Another operation was running. Retry.
Log exporting failed	It is possible the connection was interrupted.
Input parameter value is not valid	The file may not be compatible with the program.

8.5.5 Return to Program Defaults

 NOTE: Do not use the other two lines unless directed to do so by TSS.

A more drastic approach may be needed to get internal settings out of the controller. Once done, you can restore a set of parameters by using any of the previously described methods. The process is called “Wipe Retain” for anyone familiar with the Carel controller. Most likely you will not use this operation unless you are directed to do so by RenewAire Technical Sales Support (TSS).

To perform this operation, choose YES on the top line Wipe retain mem.

```

ADVANCED SERVICE
DEFAULT INSTALLATION
Wipe retain mem.: NO
Wipe NURAM mem.: NO
Wipe both mem.: NO
    
```

The unit will take a minute to get back. Then you can resume entering your parameters by any method.

THIS PAGE IS INTENTIONALLY LEFT BLANK.



## 9.0 ACCESSING FILES FROM AND PERFORMING UPDATES TO THE CONTROLLER

The controller has a total of about 92 MB of internal memory. There are several types of files that use the internal 92 MB of mass storage that are available on the controller.

- Logs—exported automatically in the root
- Alarm List—exported on demand
- Parameter sets —see *Restore Parameters (Settings)*
- Program and OS Upgrade packages—Reside in an UPGRADE folder
- Web pages—Reside in an HTTP folder
- User storage, such as documents

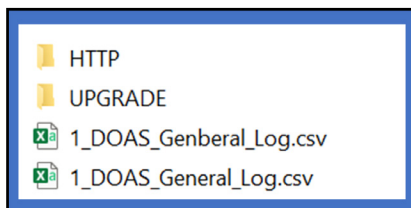

These files can be accessed through one of two methods:

- Connection via FTP through the Ethernet port
- Connection with a micro USB cable

It is also possible to export directly alarms, current log, and parameter sets to a USB drive that has either a micro USB connector or uses an adapter.

### 9.1 CONNECTIONS USING THE MICRO USB PORT

The controller has a built-in USB port where an external memory device such as a USB thumb drive can be plugged in. The external memory device may be used for backing up all settings and reported conditions such as Alarm History and presets. Backing-up is user-commanded and is done through the menu screens.

Note that the USB port is a Micro USB Type “B.” Thumb drives with a Micro USB Type B are difficult to find in some areas and it may be necessary to purchase an adapter to go from a more common Type A connector to the newer Micro Type B.

Make sure that the longer side of the USB connection is to the bottom of the controller. Do not force the connector in or you could damage the controller.

The controller requires that you use a cable or adapter with a longer end for the Micro USB side. One adapter we have found that works is the UGreen, purchased on Amazon.

**NOTE:** You cannot be connected by both methods at the same time. If you are viewing the web pages and then connect with USB, the web page will go blank until you disconnect.

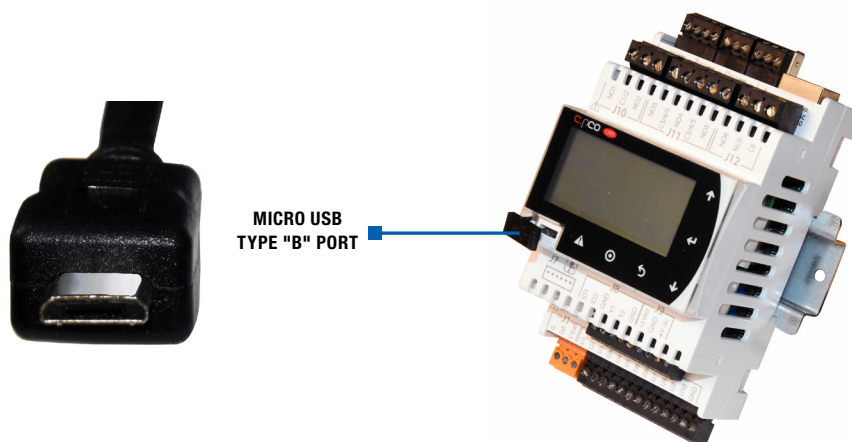

### 9.2 ALARMS AND DATA LOGS

Two types of files that are exported on demand are logs and alarm lists. They can be exported to the internal memory or the USB drive.

The export of the logs will show “In Progress” while exporting. It may take a while depending upon the size.



#### 9.2.1 Example of Alarm Log

This is the file as opened in Excel. It includes a timestamp, alarm number, alarm name, and whether the event was the start of the alarm or the end (stop).

TIME	ID	NAME	EVENT	VAR1	VAR2
2022-01-28T16:11:22+00:00	39	AI_EA_Flow_Rate_Prbs.Active	Start		
2022-01-28T16:11:22+00:00	38	AI_OA_Flow_Rate_Prbs.Active	Start		
2022-01-28T16:11:21+00:00	42	AI_Supply_Temp_Prbs.Active	Start		
2022-01-27T17:48:22+00:00	39	AI_EA_Flow_Rate_Prbs.Active	Start		
2022-01-27T17:48:22+00:00	38	AI_OA_Flow_Rate_Prbs.Active	Start		
2022-01-27T17:48:20+00:00	42	AI_Supply_Temp_Prbs.Active	Start		
2022-01-27T15:48:02+00:00	39	AI_EA_Flow_Rate_Prbs.Active	Start		
2022-01-27T15:48:02+00:00	38	AI_OA_Flow_Rate_Prbs.Active	Start		

#### 9.2.2 Example of Data Log

This is the file as opened in Excel. It includes a timestamp and values of all of the factory preconfigured log values.

TIME	EVENT	OA_Temp. Val	OA_Hum. Val	RA_Hum. Val	SA_Temp. Val	EA_Temp. Val	Cooling_C ommand.	Heating_C ommand.	RA_Temp. Val
2022-02-06T00:00:03+		22.079	23.14	20.73	20.111	21.768	0	0	22.134
2022-02-06T00:00:08+		22.079	23.14	20.74	20.134	21.756	0	0	22.134
2022-02-06T00:00:13+		22.079	23.13	20.69	20.154	21.756	0	0	22.134
2022-02-06T00:00:18+		22.067	23.15	20.71	20.166	21.756	0	0	22.134
2022-02-06T00:00:23+		22.067	23.15	20.725	20.166	21.756	0	0	22.123
2022-02-06T00:00:28+		22.067	23.14	20.695	20.178	21.756	0	0	22.123
2022-02-06T00:00:33+		22.067	23.14	20.71	20.189	21.756	0	0	22.123
2022-02-06T00:00:38+		22.067	23.14	20.705	20.199	21.745	0	0	22.123
2022-02-06T00:00:43+		22.067	23.14	20.69	20.209	21.745	0	0	22.123
2022-02-06T00:00:48+		22.067	23.14	20.735	20.209	21.745	0	0	22.123

 **NOTE:** There will be several log files on the internal drive. This is because the log is exported every night at midnight. The files are listed by day of week, where 1 = Monday. The file that starts with 9 is the file that is exported on demand.

HTTP	
System Volume Information	
UPGRADE	
1_DOAS_General_Log.csv	4,614,281
2_DOAS_General_Log.csv	4,614,281
3_DOAS_General_Log.csv	4,614,281
4_DOAS_General_Log.csv	2,067
5_DOAS_General_Log.csv	1,285,715
6_DOAS_General_Log.csv	4,614,281
7_DOAS_General_Log.csv	4,614,281

The variables that are logged are as listed here.

VARIABLE	VARIABLE	VARIABLE
OA_Temp.Val	RA_Temp.Val	Unit Status
OA_Hum.Val	OA_Enthalpy	SF_Status
RA_Hum.Val	Bypass_Command.Val	EF_Status
SA_Temp.Val	Any_Alarm_Out.Val	
EA_Temp.Val	Unit On	

### 9.3 VIEWING PARAMETER FILES

You can view the parameter files that were created in *Restore Parameters (Settings)*. You can also share them between controllers. An excerpt of a file is shown below.

#Ver.1.0 cpCO Family Exported Configuration file

#VARIABLE	DESCRIPTION	DATA TYPE DEFAULT VALUE
BACnet_Mapping	UINT	0
BMSMng.BACnetPort	UDINT	47808
BMSMng.BMS_Address_RS485	UINT	4
BMSMng.BMS_BACnetDeviceInstance	UDINT	5002
BMSMng.BMS_BACnetMSTP_MaxInfoFrames	UINT	20
BMSMng.BMS_BACnetMSTP_MaxMaster	UINT	127
BMSMng.BMS_BACnet_CmdTimeout	UINT	1500
BMSMng.BMS_BACnet_Timout	UINT	3000
BMSMng.BMS_Baud_Msk	UINT	2
BMSMng.BMS_Baud_RS485	UDINT	19200
BMSMng.BMS_Modbus_Timeout	UINT	3000
BMSMng.BMS_Parity_MSK	USINT	0

### 9.4 PERFORMING UPDATES TO THE CONTROLLER

If directed by TSS, you may need to perform an upgrade to the controller program. A very similar process is also used to field-install BACnet licenses into the controller. Refer to the BMS Access for that process.

There are three different methods to update a program, depending upon which way you connect to the controller. All three require that you have a file called “autorun.ap1,” given to you by TSS.

1. Connect via USB. This requires that you have a micro USB cable to go from your PC to the controller micro USB connection and can see the files in Windows Explorer.
2. Connect with a USB thumb drive to the micro USB connection.
3. Connect via Ethernet. This requires a PC and the ability to connect to the embedded web pages inside the controller.



NOTE: It is advised that you delete this file once you are done. Every upgrade file is named the same, regardless of version.

#### 9.4.1 Upgrade Type: Connect via USB

1. Save the parameters using the *General Save and Restore* method. Make sure you choose EXPORT! Remember the Export\_XX number you chose.
2. Carefully connect the micro USB cable to the front connection of the controller (long side to the bottom) and to your PC. Verify that you can see the files in Windows Explorer. It shows up as a USB drive. If you cannot see these files you will need to use another method.

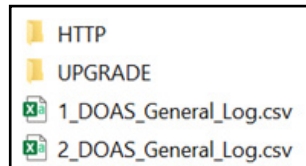

3. Put the autorun.ap1 file in the folder called "UPGRADE." You should not have other files in the root of that folder. You can have other folders in this folder, if needed.
4. You will be prompted to press "ENTER" to proceed.

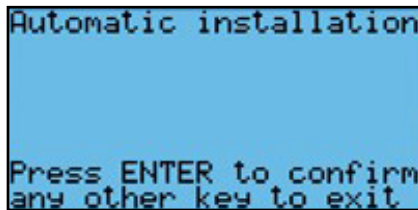

5. Once it is done you will be prompted to press "ENTER" to restart the controller.

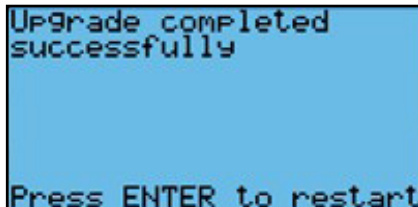

6. Restore the parameters using the *General Save and Restore* method. Make sure you choose IMPORT! Use the Export\_XX number you chose in step 1.
7. Cycle power.

#### 9.4.2 Upgrade Type: Connect with a USB Thumb Drive

Connect with a USB thumb drive to the micro USB connection.

1. Save the parameters using the *General Save and Restore* method. Make sure you choose EXPORT! Remember the Export\_XX number you chose.
2. Put the autorun.ap1 file in a folder in the root of the thumb drive called "UPGRADE."
3. Carefully connect the micro USB drive to the front connection of the controller (long side to the bottom).
4. You will be prompted to press "ENTER" to proceed.

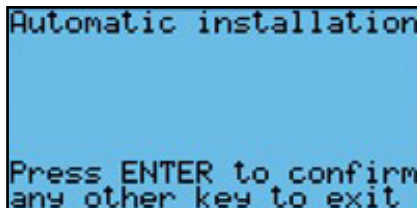

5. Once it is done you will be prompted to press “ENTER” to restart the controller.

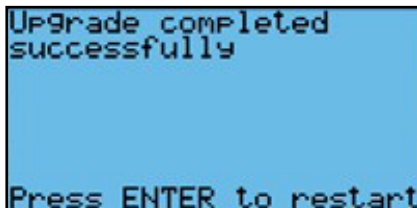

6. Restore the parameters using the *General Save and Restore* method. Make sure you choose IMPORT! Use the Export\_XX number you chose in step 1.

7. Cycle power.

#### 9.4.3 Upgrade Type: Connect via Ethernet

This requires a PC and the ability to connect to the embedded web pages inside the controller.

1. Save the parameters using the *General Save and Restore* method. Make sure you choose EXPORT! Remember the Export\_XX number you chose.
2. Go to the Upgrade Tab in the web pages.

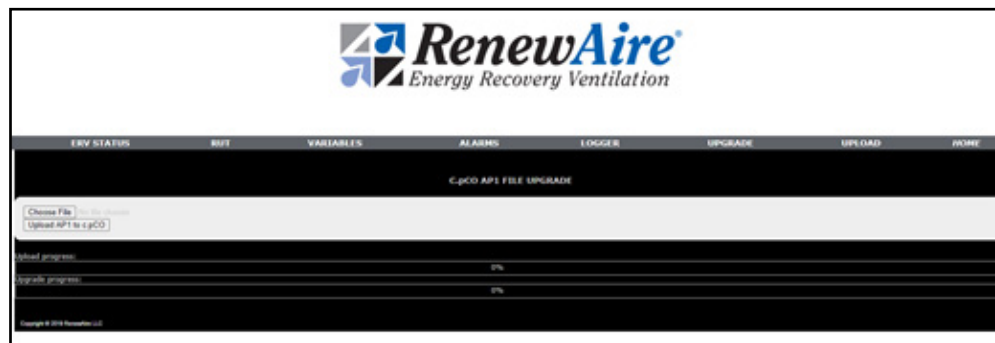

3. Click on “CHOOSE FILE” and locate the autorun.ap1 file on your PC that corresponds to the controller. Click “OPEN.” You should now see that file name next to “CHOOSE FILE.”
4. Click “Upload AP1 to c.pco.” You will see the file upload.
5. Once 100% on the upload, switch back to the RUT screen to see the upgrade taking place.
6. On the controller the program will see the file and require you to push “ENTER.” You can see that on the front of the controller itself or on the RUT page of the web pages.
7. Restore the parameters using the *General Save and Restore* method. Make sure you choose IMPORT! Use the Export\_XX number you chose in step 1.
8. Cycle power.

## 10.0 GENERAL SYSTEM MONITORING

This section describes the general system monitoring. It is here only to provide a general sense of how to monitor the system. Specific screens and information appear depending upon the features you have selected. Refer to the documentation on the specific function for the information on specific monitoring screens.

The unit is monitored through *Unit Status*.

### 10.1 MAIN SCREEN

The main screen shows either the SA temperature coming off the core, or the CA temperature, depending upon whether the unit has tempering or not. It also shows the other four temperatures near the core.

UNIT STATUS	
Conditioned Air (CA)	
68.3°F	
Outside Air	75.4°F
Return Air	75.5°F
Exhaust Air	74.0°F
03/16/22	Wed 17:24

### 10.2 OTHER STANDARD SCREENS

These screens also show standard values.

UNIT STATUS	
OA Humidity	25.0%
RA Humidity	22.3%
OA Enthalpy	21.8btu/lb
RA Enthalpy	21.3btu/lb
OA Filter	0.02"wg
RA Filter	0.05"wg
SA Temperature	68.7°F

### 10.3 FAN AND UNIT STATUS SCREENS

The first screen is helpful on starting the unit. It shows whether the fan is being asked to turn on (enabled), and whether the current sensor is detecting that it has turned on.

It also shows the *Unit Status* conditions, described in the chart below.

The seconds screen shows the speed of the fans.

UNIT STATUS	
Sup Fan Enabled	YES
Supply Fan On	YES
Exh Fan Enabled	YES
Exhaust Fan On	YES
UNIT ON	

UNIT STATUS	
Sup Fan Command	60%
Exh Fan Command	53%

UNIT STATUS CONDITIONS	
STATUS SHOWN	MEANING
Unit on	Unit is on in normal operation.
Off by alarm	Unit is off by alarm condition.
Off by BMS	Unit is off by BMS command (and BMS control is enabled).
Off by DI	Unit is off by digital input ID1.
Off by Keyboard	Unit is off by the switch through the menu screens.
EF Only Mode	Unit is in exhaust fan only mode by either ID2 or BMS.
SF Only Mode	Unit is in supply fan only mode by either ID2 or BMS.
In Device Test	Unit is in Device Test Mode.
Input Overwritten	An input is overwritten in the Sensor Overrides section.
Flush Mode	Unit is in flush mode by scheduler.
Frost Control On	Frost Control mode is on.
In Boost Mode	Unit is in Boost mode by digital input.
Smoke Purge	Unit is in Smoke Purge mode by digital input.
Econ Active	Economizer Bypass is Active.
EF Only Low Temp	Exhaust fan only by low temp (Low SA settings).

The third screen shows:

- Whether the unit is enabled. (See *Unit Status Conditions* in the first screen to assess why the unit is not on).
- Whether the OA and RA dampers are open—they should be open if the unit is ON and in occupied mode, if applicable.
- The status of the bypass damper which is used for economizer and frost control, if the features are enabled.

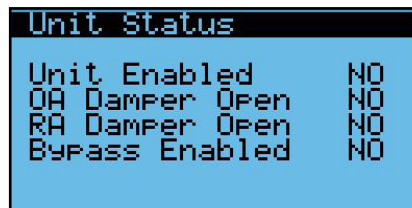

### 10.4 FROST CONTROL INFORMATION

This screen contains all frost control information.

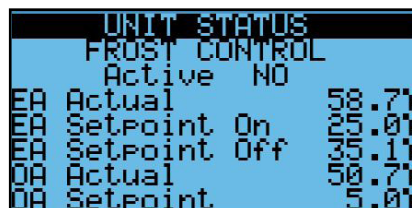

## 10.5 ENTRY TO THE I/O INFORMATION SCREEN

This screen is described in *Verifying all I/O through Unit Status Screens*.



## 10.6 VERSION INFORMATION SCREEN

This screen contains:

- Type of application
- Version of program (SW) and operating system (OS)
- Unique controller identifier



## 11.0 BMS ACCESS

The BMS settings are located in the *General Settings* after the scheduler. To get to that menu press the back button until it shows up.

### 11.1 SETTING CONTROL LEVEL

The first screen sets whether the unit will get an on/off command from the BMS. If you set this to Yes right away, the unit will not start until the BMS command is sent. Therefore, do not set this to Yes until you are ready to operate the unit.

Background: The unit will not turn on unless all of the following are true. As a result, any one can turn the unit off.

- There are no serious alarms.
- The Digital Input for start/stop (orange DIN terminal to black DIN terminal) are closed if ID1 is used for this purpose.
- The unit is turned on at the keypad.
- The time is within the scheduler "ON" time, if scheduler enabled.
- The BMS has written the unit on signal, if BMS control is enabled.

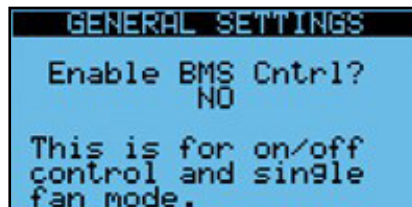

### 11.2 SETTING BMS TYPE

There are either three or five settings for BMS Type. The BACnet options will not show up unless a BACnet license has been installed.

- None
- BACnet MS/TP
- BACnet IP
- Modbus RTU
- Modbus IP



The license status can be viewed in a later screen. Refer to *Adding a BACnet License* for more information.

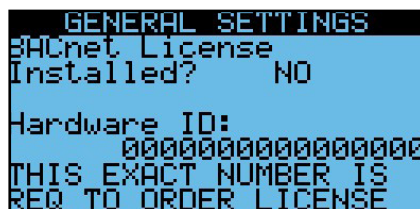

Once a protocol has been selected, additional BMS programming screens will appear. Change settings as needed. After the BMS protocol has been selected and protocol options have been selected, cycle power to the controller.

### 11.3 BACNET

RenewAire units Are BTL listed by CAREL. They allow the BMS to write to the present value by default. This means that if the BMS writes to a setpoint that setpoint can be changed by the local HMI display. (Last one in wins). Priority array is not supported.

Setpoints, in general, are saved in EEPROM memory and maintained on power loss. These are referred to as RETAINED. For retained values, DO NOT write to these values constantly. Doing so will flag an alarm and can damage the controller. If you have a need to write to a value constantly, contact TSS to discuss options.

Older units wrote to the priority array. This was cumbersome to support. They also had limited mapping. If upgrading from an older version and you want to keep that mapping, change the setting below to "Pri Array legacy." The mapping is quite different and is supported in the older documentation. Also note that priority array setpoints were not kept on power loss.

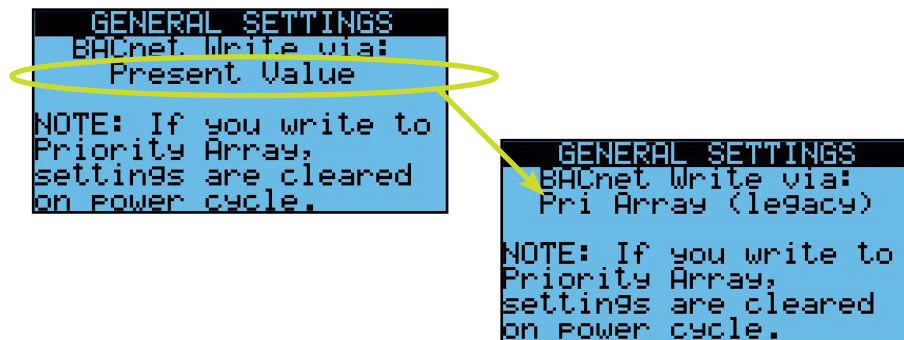

#### 11.3.1 BACnet IP Connection

Connection of BACnet IP requires a physical cable connection to the RJ45 jack on the controller. Prior to making the wiring connections, the controller is to be tested to verify proper control of the unit under local control.

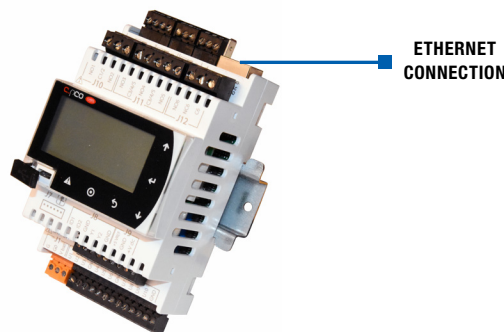

#### 11.3.2 BACnet IP Settings

First, set the IP address of the controller in the same *General Settings* area.

- Set DHCP to Off if static.
- If Static, set the IP, mask, and gateway if required.
- *Set Update?* To Yes (power will need to be cycled. This can be done after all of the other settings.)

 NOTE: The controller will only support private IP addresses which start with 192, 172, or 10.

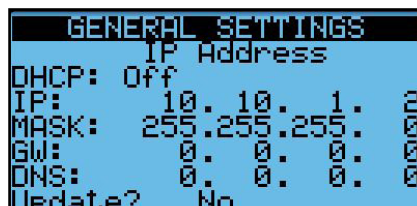

Next, set the BACnet Device ID. This screen allows you to set the ID digit by digit.

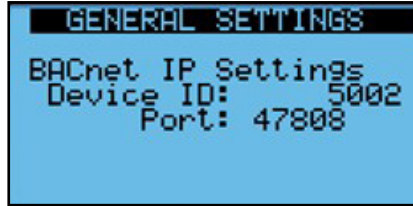

### 11.3.3 BACnet MSTP Settings

First, set the BACnet Device ID. This screen allows you to set the ID digit by digit.

 **NOTE:** Whenever the BMS type is changed, power to the controller must be cycled.

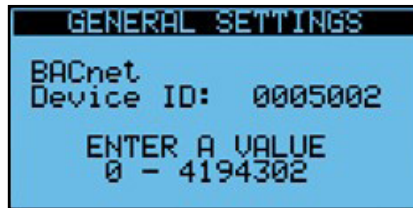

Next, set the BACnet MSTP Address, Baud rate, Max Master and Max Info frames as needed.

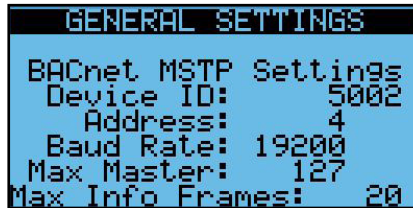

If you need to set the timing values, you can do that here.

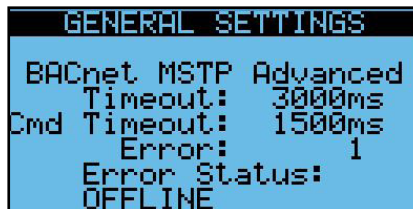

### 11.3.4 BACnet MSTP Wiring

The BACnet MSTP network is wired into the four-pin connector named J3 Disp. In the upper left-hand corner of the controller. This is also used for a RUT display so the two cannot be used at the same time. For MSTP, use the plus (+) and minus (-), as well as the GND for reference if desired.

**DO NOT** use the +Vterm terminal. If you happen to plug a three-pin block in here and use the wrong three pins you might damage the port.

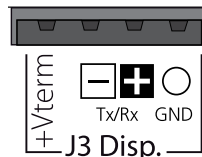

## 11.4 BACNET OBJECT LIST

TYPE	INSTANCE	VARIABLE NAME	DESCRIPTION	VALUE RANGE	READ/WRITE (RET)
Analog Input	0	OA_Temp.Val	OA Temperature	F	Read_NoWrite
Analog Input	1	OA_Hum.Val	OA Relative Humidity	%	Read_NoWrite
Analog Input	2	RA_Temp.Val	RA Temperature	F	Read_NoWrite
Analog Input	3	RA_Hum.Val	RA Relative Humidity	%	Read_NoWrite
Analog Input	4	EA_Temp.Val	EA Temperature	F	Read_NoWrite
Analog Input	5	SA_Temp.Val	SA Temperature (before tempering)	F	Read_NoWrite
Analog Input	9	SA_Hum.Val	SA Relative Humidity	%	Read_NoWrite
Analog Input	10	EA_Hum.Val	EA Relative Humidity	%	Read_NoWrite
Analog Input	11	RA_Dewpoint	RA Dewpoint	F	Read_NoWrite
Analog Input	12	OA_Dewpoint	OA Dewpoint	F	Read_NoWrite
Analog Input	24	RA_Flt_Press.Val	RA Filter Pressure	iwc	Read_NoWrite
Analog Input	25	OA_Flt_Press.Val	OA Filter Pressure	iwc	Read_NoWrite
Analog Input	26	SF_Command.Val	Supply Fan Command (actual)	%	Read_NoWrite
Analog Input	27	EF_Command.Val	Exhaust Fan Command (actual)	%	Read_NoWrite
Analog Value	35	RA_Flt_AlarmHigh	RA Filter Alarm Level	iwc	Read_Writeable (X)
Analog Value	36	OA_Flt_AlarmHigh	OA Filter Alarm Level	iwc	Read_Writeable (X)
Analog Value	37	SF_ConstSpeedSetP.Val	SF Const Speed Setpoint	%	Read_Writeable (X)
Analog Value	43	EF_ConstSpeedSetP.Val	EF Constant Speed Setpoint	%	Read_Writeable (X)
Analog Value	45	EF_SF_TrackingSetP.Val	EF SF Tracking Setpoint	%	Read_Writeable (X)
Analog Value	77	Defrost_OA_SetP.Val	Frost control OA Setpoint Low Limit	F	Read_Writeable (X)
Analog Value	78	Defrost_EA_Low_SetP.Val	Frost control EA Setpoint Low Limit	F	Read_Writeable (X)
Analog Value	79	Defrost_EA_High_SetP.Val	Frost control EA High Limit Setpoint	F	Read_Writeable (X)
Analog Value	80	BMS_SupplyFanCommand	Command used when BMS commands fans directly every cycle	%	Read_Writeable
Analog Value	81	BMS_ExhaustFanCommand	Command used when BMS commands fans directly every cycle	%	Read_Writeable
Analog Value	82	EF_Tracking_SFMode	Fan speed to run EF when it is in EF only mode and it is tracking Supply Fan	%	Read_Writeable
AnalogValue	90	SF_ConstSpeedSetP_Boost.val	SF Constant Speed Setpoint in Boost Mode	%	Read_Writeable
AnalogValue	91	EF_ConstSpeedSetP_Boost.val	EF Constant Speed Setpoint in Boost Mode	%	Read_Writeable
AnalogValue	92	SF_FlowControlSetP_Boost	SF Control Setpoint in Boost Mode	cfm	Read_Writeable

TYPE	INSTANCE	VARIABLE NAME	DESCRIPTION	VALUE RANGE	READ/WRITE (RET)
Binary Input	8	OA_Damp.Val	OA Damper Command	Closed/ Open	Read_NoWrite
Binary Input	9	RA_Damp.Val	RA Damper Command	Closed/ Open	Read_NoWrite
Binary Input	14	AlarmMng.AlrmRes	Alarm Reset Status	No/Yes	Read_NoWrite
Binary Input	15	SF_Status.Val	SF Status from Current Sensor	Off/On	Read_NoWrite
Binary Input	16	EF_Status.Val	EF Status from Current Sensor	Off/On	Read_NoWrite
Binary Input	17	Alarm_Out.Val	Serious Alarm (Also a physical output)	OK/Alarm	Read_NoWrite
Binary Input	21	UnitOn	Unit On Status	Off/On	Read_NoWrite
Binary Input	22	AI_SupplyFan.Active	Supply Fan Start Alarm	OK/Alarm	Read_NoWrite
Binary Input	23	AI_ExhaustFan.Active	Exhaust Fan Start Alarm	OK/Alarm	Read_NoWrite
Binary Input	49	Bypass_Damper.Val	Bypass Damper Command	Close/ Open	Read_NoWrite
Binary Input	72	Any_Alarm_Out.Val	Any Alarm is True Status	OK/Alarm	Read_NoWrite
Binary Input	73	BoostMode.val	Boost Mode Status	Off/On	Read_NoWrite
Binary Input	500	AI_retain.Active	Too Many Writes to Retained Memory	OK/Alarm	Read_NoWrite
Binary Input	501	AI_Err_retain_write.Active	Too Many Writes to Retained Memory	OK/Alarm	Read_NoWrite
Binary Input	502	AI_Device_Test.Active	Unit Was Left In Device Test Mode	OK/Alarm	Read_NoWrite
Binary Input	503	AI_BMS_Offline.Active	BMS is Offline	OK/Alarm	Read_NoWrite
Binary Input	504	OfflineAlrm_CPCOE_1.Active	Offline Alarm Expansion Module	OK/Alarm	Read_NoWrite
Binary Input	508	AI_Smoke.Active	Smoke Alarm Input Engaged	OK/Alarm	Read_NoWrite
Binary Input	509	AI_Freeze.Active	Freezestat Alarm Input Engaged	OK/Alarm	Read_NoWrite
Binary Input	510	AI_SupplyFan.Active	Supply Fan Start Alarm	OK/Alarm	Read_NoWrite
Binary Input	511	AI_ExhaustFan.Active	Exhaust Fan Start Alarm	OK/Alarm	Read_NoWrite
Binary Input	516	AI_SupAir_Low_Temp_Warn.Active	Supply Air Low Temperature Warning	OK/Alarm	Read_NoWrite
Binary Input	517	AI_SupAir_Low_Temp_Alarm.Active	Supply Air Low Temperature Alarm	OK/Alarm	Read_NoWrite
Binary Input	530	AI_OA_Temp_Prpb.Active	OA Temperature Sensor Open or Short	OK/Alarm	Read_NoWrite
Binary Input	531	AI_OA_Hum_Prpb.Active	OA Relative Humidity Transmitter Out of Range	OK/Alarm	Read_NoWrite
Binary Input	532	AI_RA_Temp_Prpb.Active	RA Temperature Sensor Open or Short	OK/Alarm	Read_NoWrite
Binary Input	533	AI_RA_Hum_Prpb.Active	RA Relative Humidity Transmitter Out of Range	OK/Alarm	Read_NoWrite
Binary Input	534	AI_SA_Temp_Prpb.Active	SA Temperature Sensor Open or Short	OK/Alarm	Read_NoWrite

TYPE	INSTANCE	VARIABLE NAME	DESCRIPTION	VALUE RANGE	READ/WRITE (RET)
Binary Input	535	AI_EA_Temp_Prb.Active	EA Temperature Sensor Open or Short	OK/Alarm	Read_NoWrite
Binary Input	536	AI_OA_Flt_Press_Prb.Active	OA Filter Pressure Transmitter Out of Range	OK/Alarm	Read_NoWrite
Binary Input	537	AI_RA_Flt_Press_Prb.Active	RA Filter Pressure Transmitter Out of Range	OK/Alarm	Read_NoWrite
Binary Input	560	AI_RA_Flt_Press.Active	RA Filter Needs Change	OK/Alarm	Read_NoWrite
Binary Input	561	AI_OA_Flt_Press.Active	OA Filter Needs Change	OK/Alarm	Read_NoWrite
Binary Input	562	AI_UnitLife.Active	Unit Service Request	OK/Alarm	Read_NoWrite
Binary Input	564	AI_SupplyFanLife.Active	Supply Fan Service Request	OK/Alarm	Read_NoWrite
Binary Input	565	AI_ExhaustFanLife.Active	Exhaust Fan Service Request	OK/Alarm	Read_NoWrite
Binary Value	10	OnOffUnitMng.BmsOnOff	BMS On/Off Command	Off/On	Read_Writeable
Binary Value	11	OnOffUnitMng.BmsEfOnly	BMS Exhaust Fan Only Command	Off/On	Read_Writeable
Binary Value	12	AlarmMng.AlrmResByBms	Alarm Reset BMS Command	OK/Reset	Read_Writeable
Binary Value	13	One_Fan_Mode	When single fan mode is engaged, this is the fan that will run.	Exhaust Fan/Supply Fan	Read_Writeable
MultiState Input	2	SF_ControlType_BN	SF_ControlType_BN	(See Notes)	Read_NoWrite
MultiState Input	3	EF_ControlType_BN	EF_ControlType_BN	(See Notes)	Read_NoWrite
Multistate Input	7	UnitStatus_BN	UnitStatus_BN	(See Notes)	Read_NoWrite

### 11.5 BACNET APPLICATION NOTES

#### 11.5.1 Turning the Unit On and Off

If you plan to use the BMS to turn the unit on and off, make sure you have the control enabled through the keypad. Use Binary Value 10 “OnOffUnitMng.BmsOnOff.” The status can be read at “UnitOn” at Binary Input 21.

All of the following have to be true in order for the unit to be on:

- There are no serious alarms.
- The Digital Input for start/stop (orange DIN terminal to black DIN terminal) are closed.
- The unit is turned on at the keypad.
- The time is within the scheduler “ON” time, if scheduler enabled.
- The BMS has written the unit on signal, if BMS control is enabled

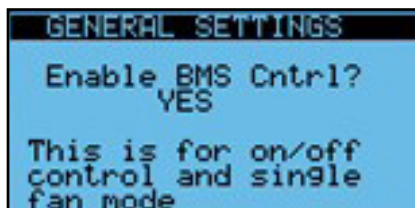

UNITSTATUS_BN: MULTISTATE INPUT 7		
VALUE	STATUS	MEANING
1	Unit on	The unit is on and running.
2	Unit switched off due to alarm	The unit is off by a serious alarm.
3	Unit switched off by BMS	The unit is off by command from the BMS.
4	Unit switched off by time band	The unit is off by the scheduler.
5	Unit switched off by digital input	The unit is off due to the ID1 input not being connected to COM.
6	Unit switched off from the local keypad	The unit is off by the setting on the menu screen.
8	Exhaust Fan Only Mode	The unit is in single fan mode with exhaust fan running.
9	Supply Fan Only Mode	The unit is in single fan mode with supply fan running.
13	Device Test	The system is in device test mode for more than an hour.
14	Sens Ovrđ Active	The system has a sensor overwritten for more than 24 hours.
15	Off by CO2 Level	Off by CO2 Level.
16	Frost Control On	Frost Control Mode Active.

### 11.5.2 Alarms

Individual alarms are mapped to Binary Inputs 500 and above. Two general alarms are available:

- Serious Alarm: Located at Binary Input 17, “Alarm\_Out.val” indicates whether there is a serious alarm that stops the unit.
- Any Alarm: Located at Binary Input 72, “Any\_Alarm\_Out.val” indicates whether there is any alarm present.

To reset the User Reset type alarms, set Binary Value 12 “AlarmMng.AlmResByBMS” to true. The program will set it back to false. You can view the status change through Binary Input 14 “AlarmMng.AlmRes.”

### 11.5.3 Temperature and Humidity Around the ERV

The following are available:

- Analog Input 0 “OA\_Temp.Val”
- Analog Input 1 “OA\_Hum.Val”
- Analog Input 2 “RA\_Temp.Val”
- Analog Input 3 “RA\_Hum.Val”
- Analog Input 4 “EA\_Temp.Val”
- Analog Input 5 “SA\_Temp.Val”

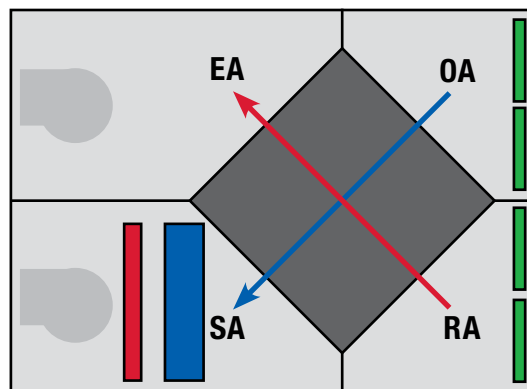

#### 11.5.4 Fan Control

The supply fan control type method can be viewed at Multistate Input 2 “SF\_ControlType\_BN.”  
The valid values are 0 = Constant Speed.

The corresponding settings is as follows:

- Constant Speed setpoint is Analog Value 37 “SF\_ConstantSpeedSetP.Val”

The command to the fan is read at Analog Input 26 “SF\_Command.Val.” The feedback from the current sensor is read at Binary Input 15 “SF\_Status.Val.”

The exhaust fan control type method can be viewed at Multistate Input 3 “EF\_ControlType\_BN.”  
The valid values are 1 = Constant Speed and 3 = SF Command Tracking.

The corresponding settings are as follows:

- Constant Speed setpoint is Analog Value 43 “EF\_ConstantSpeedSetP.Val”
- Exhaust Fan Tracking setpoint is Analog Value 45 “EF\_SF\_TrackingSetP.Val”

The command to the fan is read at Analog Input 27 “EF\_Command.Val.” The feedback from the current sensor is read at Binary Input 16 “EF\_Status.Val.”

The cooling output statuses are the following:

- Binary Input 19 “Cooling\_Enable\_1.Val” for stage one or modulating types where the demand is greater than 0
- Binary Input 20 “Cooling\_Enable\_2.Val” for stage two
- Analog Input 33 “Cooling\_Command.Val” shows a percentage for the 0–10V output.

#### 11.5.5 BMS Direct Fan Control

Available in ERV versions 03\_00\_26 ERV and higher.

Normally we use the setpoints below for constant speed fan control. These are retained variables that are kept on power loss and should not be written to constantly. You will get an alarm error and/or damage the controller by doing so.

Normal setpoint objects for constant speed fan control:

- SF\_ConstSpeedSetP.Val AV37
- EF\_ConstSpeedSetP.Val AV43

The newer versions allow a BMS system to command directly to the speed control with a non-retained variable. This is done with systems where the BMS is writing to the value every program cycle. One example would be when they use their own pressure control loop and only write the output to the fan.

The fan settings for supply and exhaust fan are independent. The user must set the control for that fan to constant speed control.

The objects used for reading the fan control type are:

- SF\_ControlType\_BN MI2
- EF\_ControlType\_BN MI3

They must be set on these screens.



In order to use this feature, the settings must be set in this screen, located in the General Settings near the other BMS settings. The user must set the corresponding fan to "YES."

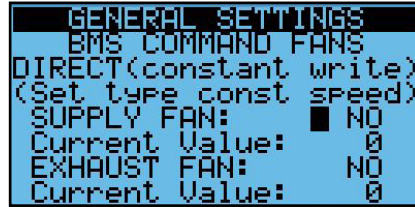

The objects used for direct writing the percentages are:

- BMS\_SupplyFanCommand AV80 expressed as 0-100%
- BMS\_ExhaustFanCommand AV81 expressed as 0-100%

In the screen above you will be able to see the value of these objects under "Current Value" for troubleshooting purposes.

The Control Setting Screen will no longer be available. Instead, the following screen(s) will be shown accordingly, with the current command shown being read-only on the screen.

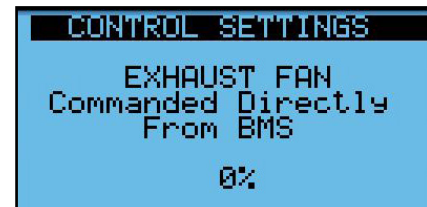
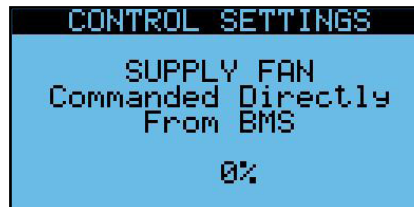

#### 11.5.6 Economizer Control

The economizer will be enabled when there is a call for cooling and the outdoor is more favorable than the return air. In this case it will open the bypass damper to bypass the enthalpic core and thus inhibit the exchange of energy. During this time the unit still uses 100% OA.

Economizing is allowed when both of the following are below their limit:

- Analog Value 52 "Economizer.Econ\_Low\_OA\_Temp\_Limit"
- Analog Value 58 "Economizer.Econ\_Low\_RA\_Temp\_Limit"

#### 11.5.7 Frost Control

The frost control function is enabled, when the OA is lower than Analog Value 77 "Defrost\_OA\_SetP.Val" minus Analog Value 78 "Defrost\_OA\_SetP.DBright," and turns off again when the OA exceeds the AV77. During this time, the supply fan is OFF and the OA damper is closed.

#### 11.5.8 Filter Monitoring

Filter pressures are read through Analog Input 24 "RA\_Fit\_Press.Val" and Analog Input 25 "OA\_Fit\_Press.Val."

Filter alarm levels are set at Analog Value 35 "RA\_Fit\_AlarmHigh" and Analog Value 36 "OA\_Fit\_AlarmHigh."

#### 11.5.9 Exhaust Fan Only Mode

If BMS control is enabled, the unit can also be put in exhaust fan only mode in occupied operation using Binary Value 74 "UnitOnOffMng.BMSEFOnly."

## 11.6 ADDING A BACNET LICENSE

### 11.6.1 Obtaining a BACnet License

If your controller does not have a BACnet license, contact whoever provided the unit to obtain one. You will need the Hardware ID number on this screen when ordering. Be sure to copy it carefully or the license will not work.

```

GENERAL SETTINGS
BACnet License
Installed?      NO

Hardware ID:
               0000000000000000
THIS EXACT NUMBER IS
REQ TO ORDER LICENSE
  
```

The license will be delivered as a file with extension “.ap1.”

### 11.6.2 Installing the BACnet License via Web Page

#### Prerequisites

- Have ap1 BACnet upgrade file(s) located on your PC
- Ethernet connection from the PC to the controller and view the web page

#### Steps

1. Go to the Upgrade Tab in the web pages.

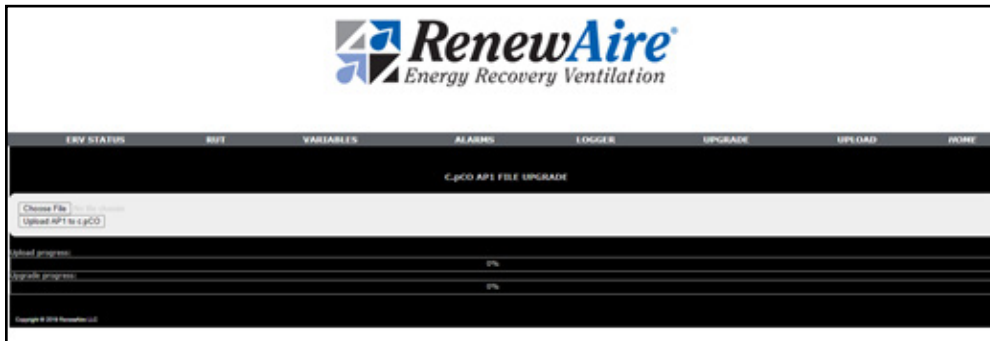

2. Click on “CHOOSE FILE” and locate the file on your PC that corresponds to the controller.  
HINT: The ending character in the UID of the controller should match the character of the ap1 file. Click “OPEN.”
3. You should now see that file name next to “CHOOSE FILE.” Click “Upload AP1 to c.pco.” You will see the file upload.
4. On the controller the program will see the file and require you to push “ENTER.” You can see that on the front of the controller itself or on the RUT page of the web pages.
5. Once the upgrade is finished the controller will ask you to reboot.

You can then verify that the license is installed by going to the RUT page.

```

GENERAL SETTINGS
BACnet License
Installed?      NO

Hardware ID:
               0000000000000000
THIS EXACT NUMBER IS
REQ TO ORDER LICENSE
  
```

### 11.6.3 Installing the BACnet License via USB Drive

#### Prerequisites

- Micro USB Adapter.
- USB Stick with the file in a folder in the root called “UPGRADE.” The file you received should be in that folder.

#### Steps

1. Carefully insert the micro USB end into the controller front under the door with the wide side to the bottom.
2. You should now see a prompt telling you press the enter key.
3. Once finished you will be prompted to press “ENTER” again.

You should now see the license is installed in the controller screen.

### 11.6.4 Installing the BACnet License via USB Connection

#### Prerequisites:

- PC
- Micro USB cable with the ability to plug in with a PC and have the controller appear as a USB drive in your Windows Explorer

#### Steps

1. Carefully insert the micro USB end into the controller front under the door with the wide side to the bottom.
2. You should see a folder called “UPGRADE” in the controller. Put the file in that folder.
3. Once finished you will be prompted to press “ENTER” again.

You should now see the license is installed in the controller screen.

## 11.7 MODBUS

The Modbus utilizes the standard registers and references them as an offset. For example, an offset of Input Register 0 is Register 30,001 and an offset for Holding Register 0 is register 40,001. All values are shown in decimal format. The implementation also uses Coils and Discrete Inputs in a similar manner.

### 11.7.1 Modbus TCP Connection

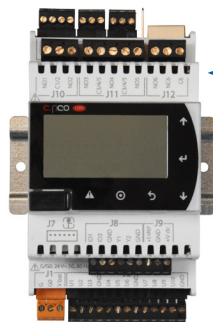

Connection of Modbus TCP requires a physical cable connection to the RJ45 jack on the controller. Prior to making the wiring connections, the controller is to be tested to verify proper control of the ERV unit under local control.

FIGURE 11.2.0 ETHERNET CONNECTION

### 11.7.2 Modbus TCP Settings

First, set the IP address of the controller in the same *General Settings* area.

- Set DHCP to Off if static
- If Static, set the IP, mask, and gateway if required.
- *Set Update?* To Yes (Power will need to be cycled. This can be done after all of the other settings.)

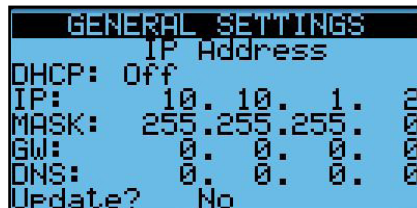

Then set the timeout parameter, if needed.

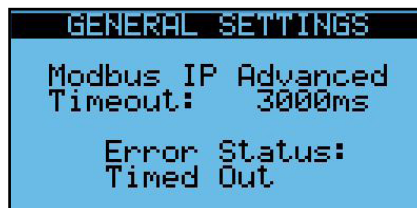

### 11.7.3 Modbus RTU Settings

First, set the address, baud rate, stop bits and parity.

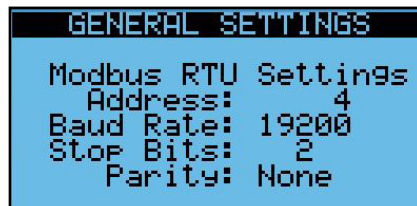

Then set the timeout parameter if needed.

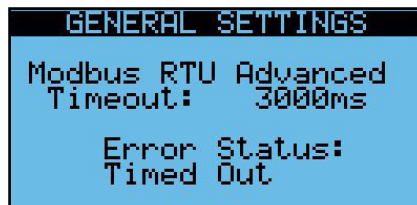

### 11.7.4 Modbus RTU Wiring

The Modbus RTU network is wired into the four-pin connector named J3 Disp. In the upper left-hand corner of the controller. This is also used for a RUT display so the two cannot be used at the same time. For Modbus RTU, use the plus (+) and minus (-), as well as the GND for reference if desired.

DO NOT use the +Vterm terminal. If you happen to plus a three-pin block in here and use the wrong three pins you might damage the port.

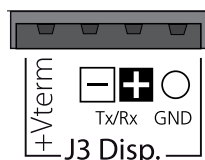

 NOTE: The controller will only support private IP addresses which start with 192, 172, or 10.

## 11.8 MODBUS REGISTER LIST

Modbus Registers with an offset of 0 have been duplicated at register 98 to accommodate Automated Logic Systems and other systems that cannot map 0.

TYPE	#	VARIABLE	DESCRIPTION	RANGE	READ/WRITE MODE (RET)
Coil	0	OnOffUnitMng.BmsOnOff	BMS On/Off Command	Off/On	Read_Writeable
Coil	1	OnOffUnitMng.BmsEfOnly	BMS Exhaust Fan Only Command	Off/On	Read_Writeable
Coil	2	AlarmMng.AlrmResByBms	Alarm Reset BMS Command	OK/Reset	Read_Writeable
Coil	7	Heating_Enable_1.Val	Heating Stage 1 BMS Enable	Off/On	Read_Writeable
Coil	98	OnOffUnitMng.BmsOnOff	BMS On/Off Command	Off/On	Read_NoWrite
DiscreteInput	0	OA_Damp.Val	OA Damper Command	Closed/Open	Read_NoWrite
DiscreteInput	1	RA_Damp.Val	RA Damper Command	Closed/Open	Read_NoWrite
DiscreteInput	2	AlarmMng.AlrmRes	Alarm Reset Status	No/Yes	Read_NoWrite
DiscreteInput	3	SF_Status.Val	SF Status from Current Sensor	Off/On	Read_NoWrite
DiscreteInput	4	EF_Status.Val	EF Status from Current Sensor	Off/On	Read_NoWrite
DiscreteInput	5	Alarm_Out.Val	Serious Alarm (Also a physical output)	OK/Alarm	Read_NoWrite
DiscreteInput	9	UnitOn	Unit On Status	Off/On	Read_NoWrite
DiscreteInput	21	AI_SupplyFan.Active	Supply Fan Start Alarm	OK/Alarm	Read_NoWrite
DiscreteInput	22	AI_ExhaustFan.Active	Exhaust Fan Start Alarm	OK/Alarm	Read_NoWrite
DiscreteInput	12	Bypass_Damp.Val	Bypass Damper Command	Close/Open	Read_NoWrite
DiscreteInput	20	Any_Alarm_Out.Val	Any Alarm is True Status	OK/Alarm	Read_NoWrite
DiscreteInput	98	OA_Damp.Val	OA Damper Command	Closed/Open	Read_NoWrite
HoldingRegister	0	RA_Flt_AlarmHigh	RA Filter Alarm Level	iwc	Read_Writeable (X)
HoldingRegister	2	OA_Flt_AlarmHigh	OA Filter Alarm Level	iwc	Read_Writeable (X)
HoldingRegister	4	SF_ConstSpeedSetP.Val	SF Const Speed Setpoint	%	Read_Writeable (X)
HoldingRegister	16	EF_ConstSpeedSetP.Val	EF Constant Speed Setpoint	%	Read_Writeable (X)
HoldingRegister	20	EF_SF_TrackingSetP.Val	EF SF Tracking Setpoint	%	Read_Writeable (X)
HoldingRegister	98	RA_Flt_AlarmHigh	RA Filter Alarm Level	iwc	Read_Writeable (X)
InputRegister	0	OA_Temp.Val	OA Temperature	F	Read_NoWrite
InputRegister	2	OA_Hum.Val	OA Relative Humidity	%	Read_NoWrite
InputRegister	4	RA_Temp.Val	RA Temperature	F	Read_NoWrite
InputRegister	6	RA_Hum.Val	RA Relative Humidity	%	Read_NoWrite
InputRegister	8	EA_Temp.Val	EA Temperature	F	Read_NoWrite
InputRegister	10	SA_Temp.Val	SA Temperature (before tempering)	F	Read_NoWrite
InputRegister	16	RA_Flt_Press.Val	RA Filter Pressure	iwc	Read_NoWrite

TYPE	#	VARIABLE	DESCRIPTION	RANGE	READ/WRITE MODE (RET)
InputRegister	18	OA_Flt_Press.Val	OA Filter Pressure	iwc	Read_NoWrite
InputRegister	20	SF_Command.Val	Supply Fan Command (actual)	%	Read_NoWrite
InputRegister	22	EF_Command.Val	Exhaust Fan Command (actual)	%	Read_NoWrite
InputRegister	98	OA_Temp.Val	OA Temperature	F	Read_NoWrite
InputRegister	42	SF_ControlType_BN	SF_ControlType_BN	(See Notes)	Read_NoWrite
InputRegister	43	EF_ControlType_BN	EF_ControlType_BN	(See Notes)	Read_NoWrite
InputRegister	50	UnitStatus_BN	UnitStatus_BN	(See Notes)	Read_NoWrite

## 11.9 MODBUS APPLICATION NOTES

### 11.9.1 Turning the Unit ON and OFF

If you plan to use the BMS to turn the unit on and off, make sure you have the control enabled through the keypad. Use Modbus Coil "OnOffUnitMng.BmsOnOff" at Coil 0. The status can be read at "UnitOn" at Discrete Input 9.

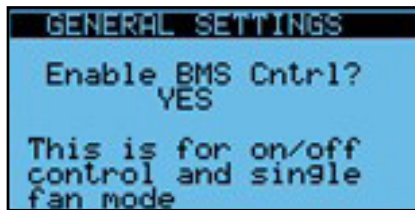

All of the following have to be true in order for the unit to be on:

- There are no serious alarms.
- The Digital Input for start/stop (orange DIN terminal to black DIN terminal) are closed if ID1 is configured for this purpose.
- The unit is turned on at the keypad.
- The time is within the scheduler "ON" time, if scheduler enabled.
- The BMS has written the unit on signal, if BMS control is enabled.

UNITSTATUS_BN: INPUT REGISTER 50		
VALUE	STATUS	MEANING
1	Unit on	The unit is on and running.
2	Unit switched off due to alarm	The unit is off by a serious alarm.
3	Unit switched off by BMS	The unit is off by command from the BMS.
4	Unit switched off by time band	The unit is off by the scheduler.
5	Unit switched off by digital input	The unit is off due to the ID1 input not being connected to COM.
6	Unit switched off from the local keypad	The unit is off by the setting on the menu screen.
8	Exhaust Fan Only Mode	The unit is in single fan mode with exhaust fan running.
9	Supply Fan Only Mode	The unit is in single fan mode with supply fan running.
13	Device Test	The system is in device test mode for more than an hour.
14	Sens Ovrđ Active	The system has a sensor overwritten for more than 24 hours.
16	Frost Control On	Frost Control Mode Active.

### 11.9.2 Alarms

Two general alarms are available:

- Serious Alarm: Located at Discrete Input 5, “Alarm\_Out.val” indicates whether there is a serious alarm that stops the unit.
- Any Alarm: Located at Discrete Input 20, “Any\_Alarm\_Out.val” indicates whether there is any alarm present.

To reset the User Reset type alarms, set Coil 0 (or 98) “AlarmMng.AlrmResByBMS” to true. The program will set it back to false. You can view the status change through Discrete Input 2 “AlarmMng.AlrmRes.”

### 11.9.3 Temperature and Humidity Around the ERV

The following are available:

- Input Register 0 “OA\_Temp.Val”
- Input Register 2 “OA\_Hum.Val”
- Input Register 4 “RA\_Temp.Val”
- Input Register 6 “RA\_Hum.Val”
- Input Register 8 “EA\_Temp.Val”
- Input Register 10 “SA\_Temp.Val”

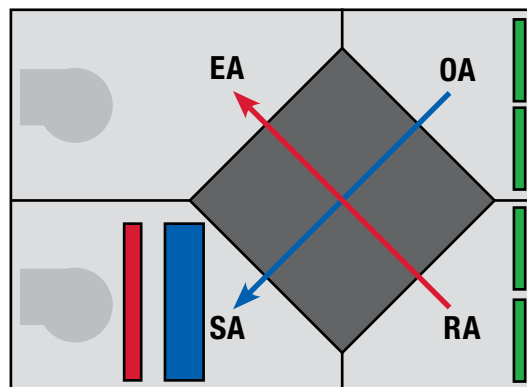

#### 11.9.4 Fan Control

The supply fan control type method can be viewed at Input Register 42 "SF\_ControlType\_BN."  
The valid values are 0 = Constant Speed.

The corresponding setting is as follows:

- Constant Speed setpoint is Holding Register 4 "SF\_ConstantSpeedSetP.Val"

The command to the fan is read at Input Register 20 "SF\_Command.Val." The feedback from the current sensor is read at Discrete Input 3 "SF\_Status.Val."

The exhaust fan control type method can be viewed at Input Register 43 "EF\_ControlType\_BN."  
The valid values are 1 = Constant Speed, 3 = SF Command Tracking, .

The corresponding settings are as follows:

- Constant Speed setpoint is Holding Register 16 "EF\_ConstantSpeedSetP.Val"
- Exhaust Fan Tracking setpoint is Holding Register 20 "EF\_SF\_TrackingSetP.Val"

The command to the fan is read at Input Register 22 "EF\_Command.Val." The feedback from the current sensor is read at Discrete Input 4 "EF\_Status.Val."

#### 11.9.5 BMS Direct Fan Control

Available in ERV versions 03\_00\_26 ERV and higher.

Normally we use the setpoints below for constant speed fan control. These are retained variables that are kept on power loss and should not be written to constantly. You will get an alarm error and/or damage the controller by doing so.

Normal setpoint registers for constant speed fan control:

- SF\_ConstSpeedSetP.Val HR4
- EF\_ConstSpeedSetP.Val HR16

The newer versions allow a BMS system to command directly to the speed control with a non-retained variable. This is done with systems where the BMS is writing to the value every program cycle. One example would be when they use their own pressure control loop and only write the output to the fan.

The fan settings for supply and exhaust fan are independent. The user must set the control for that fan to constant speed control.

The registers used for reading the fan control type are:

- SF\_ControlType\_BN IR42
- EF\_ControlType\_BN IR43

They must be set on these screens.



In order to use this feature, the settings must be set in this screen, located in the General Settings near the other BMS settings. The user must set the corresponding fan to "YES."

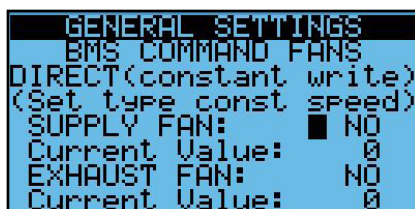

The registers used for direct writing the percentages are:

- BMS\_SupplyFanCommand HR70 expressed as 0-100%
- BMS\_ExhaustFanCommand HR72 expressed as 0-100%

In the screen above you will be able to see the value of these objects under “Current Value” for troubleshooting purposes.

The Control Setting Screen will no longer be available. Instead, the following screen(s) will be shown accordingly, with the current command shown being read-only on the screen.

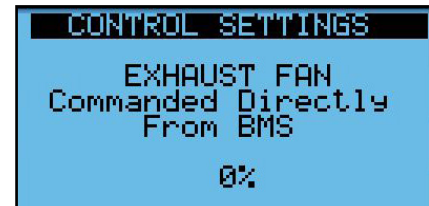

#### 11.9.6 Frost Control

The frost control function is enabled when the OA is lower than Holding Register 64 “Defrost\_OA\_SetP.Val” minus Holding Register 66 “Defrost\_OA\_SetP.DBright,” and turns off again when the OA exceeds the HR66. During this time the supply fan is off and the OA damper is closed.

#### 11.9.7 Filter Monitoring

Filter pressures are read through Input Register 16 “RA\_Flt\_Press.Val” and Input Register 18 “OA\_Flt\_Press.Val.”

Filter alarm levels are set at Holding Register 0 (or 98) “RA\_Flt\_AlarmHigh” and Holding Register 2 “OA\_Flt\_AlarmHigh.”

#### 11.9.8 Exhaust Fan Only Mode

If BMS control is enabled, the unit can also be put in exhaust fan only mode in occupied operation using Coil 1 “UnitOnOffMng.BMSEFOnly.”

## 12.0 ADVANCED SERVICE

This area gives advanced service information, as described. These screens are used infrequently.

### 12.1 RUN HOURS AND STARTS

For the ERV unit as well as each fan and compressor, if applicable, there is a screen that shows the run hours as well as the number of starts. This screen also lets you specify a threshold for alarm to alert that service is required and the ability to reset those numbers once service is performed.

```

ADVANCED SERVICE
UNIT SERVICE INFO
Run Hours: 0
Svc Thr: 200000hr
STATUS:OK
Reset Svc Hrs: NO
Starts: 0
Reset Starts: NO
    
```

```

ADVANCED SERVICE
SUPPLY FAN SVC INFO
Run Hours: 22
Svc Thr: 200000hr
STATUS:OK
Reset Svc Hrs: NO
Starts: 1
Reset Starts: NO
    
```

### 12.2 LAST POWER LOSS

This screen gives information on the last time the unit was powered down as well as the length of time the unit was powered down for troubleshooting.

```

ADVANCED SERVICE
LAST POWER LOSS
Current time:
18/12/25 13:56:06
PowerOff time:
11/12/25 14:30:48
Length last time off:
0Days 0Hrs 11Min
    
```

### 12.3 INTERNAL MEMORY WRITES

This screen gives information memory writes and the cycle speed of the applications. This would normally be used to give information to TSS, if requested.

```

ADVANCED SERVICE
Ret mem writes: 2526
Main task:
500ms 2.0Cycle/s
    
```

### 12.4 ALARM INITIALIZATION

This screen will allow you to delete the alarm logs.

```

ADVANCED SERVICE
Alarm initialization
Delete alarm logs?
NO
    
```

### 12.5 MEMORY WIPE

This screen will allow to wipe retained values (most setpoints) and/or NVRAM (clock and IP settings). You should only use this screen if directed to do so by TSS.







**13.3 CONTROLLER UPDATES**

Anytime an updated controller program is provided by the factory and installed by the user, it should be recorded here:

DATE

**13.4 SETTINGS BACKUP FILE**

Use this space to record whether or not a backup has been performed to an external memory device (USB stick) and indicate where the USB stick is to be found.

Controller System Backup has been performed:  Yes

Type/ID of memory device:

Storage location of external memory device:

## 14.0 REFERENCE

### 14.1 TUNING PI CONTROL LOOPS

For any heating or cooling device that has a variable output and uses a variable control signal (including HGRH), the desired action is for the heating/cooling device to reach the setpoint quickly and smoothly. The controller monitors a selected temperature sensor and any variation from the setpoint is considered “ERROR.” The controller senses the Error and sends a control signal (call for heat or call for cooling) to the heating/cooling device. This control signal is referred to as a “command.” For most variable output hardware, the command will be an analog 0–10VDC signal.

This controller uses PI programming to control the response to Error. PI programming uses two different types of settings to control the command; KP and Ti

KP = proportional gain

- Responds directly to difference between setpoint and actual
- Larger KP values will cause a greater output response and eventually will oscillate.

Ti = integral band

- Responds to the accumulated difference between setpoint and actual
- Larger Ti values will cause a slower output response, very small values eventually will oscillate.

CONTROL SETTINGS	
COOLING - PDX	
Setpoint	45.0°F
KP	7.0
Ti	100

#### 14.1.1 Proportional Constant (KP)

The Proportional Constant (KP) determines the strength of the command for any given error.

**Example:** the setpoint in a heating system is 72°F. The actual temperature is 71°F so the Error is 10°F, which requires very little heat from the heater. The controller sees there is an error and immediately sends a call for heat that starts at 0.1% strength and ramps up as needed, but the rate of increase tapers off as the Error decreases. The rate of increase is proportional to the amount of Error. When the controller senses that the Error is decreasing, it will slow the rate of increase of the command.

- When the Error is small, the rate of increase of the command is slow.
- When the Error is large, the rate of increase is greater (the command responds proportionally to the amount of Error).

The factory default KP setting for most heating and cooling devices is 1, which produces a low and slow response. If the response is too slow, the KP setting can be increased so that the command will be stronger and faster.

**Example:** when the KP setting is 1 and Ti is set for 30 (the factory defaults) and there is a 1°F Error, it takes about 50 seconds for the command to change by 10%. If the KP setpoint is changed to 10, it takes about 5 seconds for the command to change by 10%. For most installations, the KP value will have to be increased to speed up changes in the command signal to an acceptable level. Setting the KP value too high will result in the heater/cooler overshooting the setpoint constantly.

- If the KP value is too low, the command will change too slowly and the setpoint may take too long to reach.
- If the KP value is too high, the command will change to 100% too quickly and the setpoint will be over-shot. This results in the heating/cooling device switching “ON” and “OFF” constantly.

### 14.1.2 Time Integral (Ti)

If the KP setting did not have some means of control, the resulting command signals would constantly over-shoot the setpoint. The Time Integral causes the controller to re-examine the amount of error at specific time intervals to see the amount of error remaining. Ti produces a damping effect on the KP value to reduce over-shooting the setpoint. Ti is an actual measure of time so that when the value is reduced, the frequency of sampling increases.

**Example:** the default Ti value is 30. If the value were changed to 15, sampling would occur twice as often. If the value were changed from 30 to 60, sampling would occur only half as often. If Ti were changed to 500, the result is that the sampling value would be insignificant and corrections to KP would not be happening.

- If the Ti value is set too low (meaning that sampling is occurring too often), the increase in the command signal will immediately begin to slow and keep getting slower because Ti is damping the KP value too much.
- If Ti is set too high (sampling is not occurring often enough), the Command signal will overshoot the setpoint in both a negative and positive direction, causing short-cycling of the heating device.

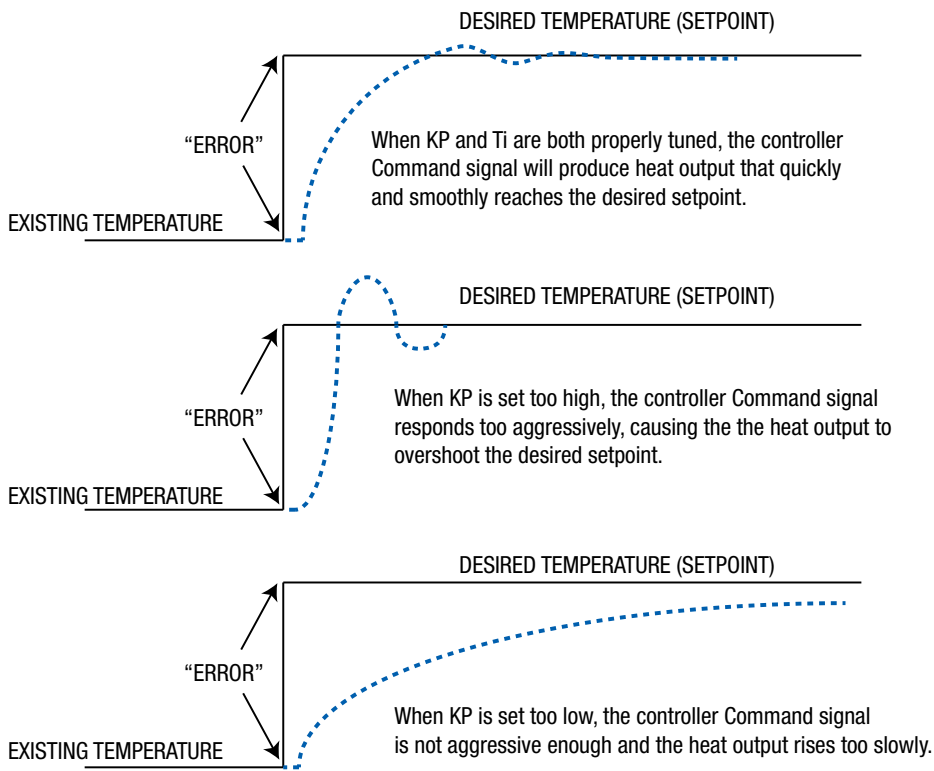

FIGURE 14.1.0 KP SETPOINT CHARTS

The process of adjusting KP and Ti to provide the most satisfactory controller output is known as tuning the controller. There are some sophisticated math equations that can be done to predict where the KP and Ti settings should be, but in the field, adjustment is normally done by a trial-and-error method. The KP setting is first adjusted and then the Ti setting is adjusted to manage the KP setting.

Tools needed:

- Laptop computer to view the Heating screens and make adjustments to KP and Ti.
- A stopwatch or watch with a second hand to monitor times.
- Connect the laptop to the controller via ethernet.

#### 14.1.3 Establish a KP Setting

Use the KP Adjustment Chart to track and log test trials of different controller settings. Make copies of the adjustment charts, as needed.

- Go to Main Menu > Unit Status > Heating. Note the temperature here.
- Go to Main Menu > Control Settings> Heating.
- Set the KP value at 5.
- Set the Ti value at 500. This will make the sampling frequency so low that it is essentially of no consequence and permits adjustment of KP without being affected by Ti.
- Set the setpoint for 20°F warmer than the current temperature as noted above. (Change the setpoint last because the controller will immediately respond to the setpoint change, using the KP and Ti settings that it currently has.)
- Click the “ENTER” button and then immediately go back to Main Menu > Unit Status > Heating.

View the Command and Temperature lines on the screen and enter the data at each time interval that was selected.

When the trial is complete, view the Command line on the chart to see how quickly it ramps up to 100%. If the Command percentage is rising too slowly, increase the KP value and run the trial again. The Command percentage should reach 100% (or very nearly) within 2–4 minutes.

Repeat the process, but move the heating setpoint 20°F lower than the current temperature and change the KP value to a larger value, possibly 10 or 15 larger than the previous trial.

Make data entries on the KP Adjustment Chart (following page) to help track changes to the KP settings. Select the most appropriate KP setting.

#### 14.1.4 Establish a Ti Setting

- Leave the KP value as found above.
- Set the Ti value at the default value of 30. For each trial, increase the Ti setting.
- Follow the same process as described above. Repeat the trials until the smoothest response is found that does not cause over-shooting or oscillation of the heating command.

#### 14.1.5 Verify the Combined KP and Ti Settings

When both KP and Ti have been set, run one final trial with the KP and Ti settings at their new values and record the results in the final chart. This ensures that the results are repeatable. Temperature and Command readings are obtained from Main Menu > Unit Status > Heating

For Elapsed Time, select a convenient amount of time to allow between readings (example: 30 seconds).

In the first column of each trial, fill in the starting data for the trial

DEVICES BEING ADJUSTED

--

KP Adjustment Trial 1

KP SETTING	<input type="text"/>						
HEATING SETPOINT	<input type="text"/>						
TEMPERATURE	<input type="text"/>	<input type="text"/>	<input type="text"/>	<input type="text"/>	<input type="text"/>	<input type="text"/>	<input type="text"/>
COMMAND PERCENTAGE	<input type="text"/>	<input type="text"/>	<input type="text"/>	<input type="text"/>	<input type="text"/>	<input type="text"/>	<input type="text"/>
ELAPSED TIME	0	<input type="text"/>	<input type="text"/>	<input type="text"/>	<input type="text"/>	<input type="text"/>	<input type="text"/>

KP Adjustment Trial 2

KP SETTING	<input type="text"/>						
HEATING SETPOINT	<input type="text"/>						
TEMPERATURE	<input type="text"/>	<input type="text"/>	<input type="text"/>	<input type="text"/>	<input type="text"/>	<input type="text"/>	<input type="text"/>
COMMAND PERCENTAGE	<input type="text"/>	<input type="text"/>	<input type="text"/>	<input type="text"/>	<input type="text"/>	<input type="text"/>	<input type="text"/>
ELAPSED TIME	0	<input type="text"/>	<input type="text"/>	<input type="text"/>	<input type="text"/>	<input type="text"/>	<input type="text"/>

KP Adjustment Trial 3

KP SETTING	<input type="text"/>						
HEATING SETPOINT	<input type="text"/>						
TEMPERATURE	<input type="text"/>	<input type="text"/>	<input type="text"/>	<input type="text"/>	<input type="text"/>	<input type="text"/>	<input type="text"/>
COMMAND PERCENTAGE	<input type="text"/>	<input type="text"/>	<input type="text"/>	<input type="text"/>	<input type="text"/>	<input type="text"/>	<input type="text"/>
ELAPSED TIME	0	<input type="text"/>	<input type="text"/>	<input type="text"/>	<input type="text"/>	<input type="text"/>	<input type="text"/>

KP Adjustment Trial 4

KP SETTING	<input type="text"/>						
HEATING SETPOINT	<input type="text"/>						
TEMPERATURE	<input type="text"/>	<input type="text"/>	<input type="text"/>	<input type="text"/>	<input type="text"/>	<input type="text"/>	<input type="text"/>
COMMAND PERCENTAGE	<input type="text"/>	<input type="text"/>	<input type="text"/>	<input type="text"/>	<input type="text"/>	<input type="text"/>	<input type="text"/>
ELAPSED TIME	0	<input type="text"/>	<input type="text"/>	<input type="text"/>	<input type="text"/>	<input type="text"/>	<input type="text"/>

FIGURE 14.1.1 KP ADJUSTMENT WORKSHEET

DEVICES BEING ADJUSTED

--

Ti Adjustment Trial 1

KP Setting for all Trials

Ti SETTING	<input style="width: 40px; height: 15px;" type="text"/>							
HEATING SETPOINT	<input style="width: 40px; height: 15px;" type="text"/>							
TEMPERATURE	<input style="width: 40px; height: 15px;" type="text"/>	<input style="width: 40px; height: 15px;" type="text"/>	<input style="width: 40px; height: 15px;" type="text"/>	<input style="width: 40px; height: 15px;" type="text"/>	<input style="width: 40px; height: 15px;" type="text"/>	<input style="width: 40px; height: 15px;" type="text"/>	<input style="width: 40px; height: 15px;" type="text"/>	<input style="width: 40px; height: 15px;" type="text"/>
COMMAND PERCENTAGE	<input style="width: 40px; height: 15px;" type="text"/>	<input style="width: 40px; height: 15px;" type="text"/>	<input style="width: 40px; height: 15px;" type="text"/>	<input style="width: 40px; height: 15px;" type="text"/>	<input style="width: 40px; height: 15px;" type="text"/>	<input style="width: 40px; height: 15px;" type="text"/>	<input style="width: 40px; height: 15px;" type="text"/>	<input style="width: 40px; height: 15px;" type="text"/>
ELAPSED TIME	0	<input style="width: 40px; height: 15px;" type="text"/>	<input style="width: 40px; height: 15px;" type="text"/>	<input style="width: 40px; height: 15px;" type="text"/>	<input style="width: 40px; height: 15px;" type="text"/>	<input style="width: 40px; height: 15px;" type="text"/>	<input style="width: 40px; height: 15px;" type="text"/>	<input style="width: 40px; height: 15px;" type="text"/>

Ti Adjustment Trial 2

Ti SETTING	<input style="width: 40px; height: 15px;" type="text"/>							
HEATING SETPOINT	<input style="width: 40px; height: 15px;" type="text"/>							
TEMPERATURE	<input style="width: 40px; height: 15px;" type="text"/>	<input style="width: 40px; height: 15px;" type="text"/>	<input style="width: 40px; height: 15px;" type="text"/>	<input style="width: 40px; height: 15px;" type="text"/>	<input style="width: 40px; height: 15px;" type="text"/>	<input style="width: 40px; height: 15px;" type="text"/>	<input style="width: 40px; height: 15px;" type="text"/>	<input style="width: 40px; height: 15px;" type="text"/>
COMMAND PERCENTAGE	<input style="width: 40px; height: 15px;" type="text"/>	<input style="width: 40px; height: 15px;" type="text"/>	<input style="width: 40px; height: 15px;" type="text"/>	<input style="width: 40px; height: 15px;" type="text"/>	<input style="width: 40px; height: 15px;" type="text"/>	<input style="width: 40px; height: 15px;" type="text"/>	<input style="width: 40px; height: 15px;" type="text"/>	<input style="width: 40px; height: 15px;" type="text"/>
ELAPSED TIME	0	<input style="width: 40px; height: 15px;" type="text"/>	<input style="width: 40px; height: 15px;" type="text"/>	<input style="width: 40px; height: 15px;" type="text"/>	<input style="width: 40px; height: 15px;" type="text"/>	<input style="width: 40px; height: 15px;" type="text"/>	<input style="width: 40px; height: 15px;" type="text"/>	<input style="width: 40px; height: 15px;" type="text"/>

Ti Adjustment Trial 3

Ti SETTING	<input style="width: 40px; height: 15px;" type="text"/>							
HEATING SETPOINT	<input style="width: 40px; height: 15px;" type="text"/>							
TEMPERATURE	<input style="width: 40px; height: 15px;" type="text"/>	<input style="width: 40px; height: 15px;" type="text"/>	<input style="width: 40px; height: 15px;" type="text"/>	<input style="width: 40px; height: 15px;" type="text"/>	<input style="width: 40px; height: 15px;" type="text"/>	<input style="width: 40px; height: 15px;" type="text"/>	<input style="width: 40px; height: 15px;" type="text"/>	<input style="width: 40px; height: 15px;" type="text"/>
COMMAND PERCENTAGE	<input style="width: 40px; height: 15px;" type="text"/>	<input style="width: 40px; height: 15px;" type="text"/>	<input style="width: 40px; height: 15px;" type="text"/>	<input style="width: 40px; height: 15px;" type="text"/>	<input style="width: 40px; height: 15px;" type="text"/>	<input style="width: 40px; height: 15px;" type="text"/>	<input style="width: 40px; height: 15px;" type="text"/>	<input style="width: 40px; height: 15px;" type="text"/>
ELAPSED TIME	0	<input style="width: 40px; height: 15px;" type="text"/>	<input style="width: 40px; height: 15px;" type="text"/>	<input style="width: 40px; height: 15px;" type="text"/>	<input style="width: 40px; height: 15px;" type="text"/>	<input style="width: 40px; height: 15px;" type="text"/>	<input style="width: 40px; height: 15px;" type="text"/>	<input style="width: 40px; height: 15px;" type="text"/>

Ti Adjustment Trial 4

Ti SETTING	<input style="width: 40px; height: 15px;" type="text"/>							
HEATING SETPOINT	<input style="width: 40px; height: 15px;" type="text"/>							
TEMPERATURE	<input style="width: 40px; height: 15px;" type="text"/>	<input style="width: 40px; height: 15px;" type="text"/>	<input style="width: 40px; height: 15px;" type="text"/>	<input style="width: 40px; height: 15px;" type="text"/>	<input style="width: 40px; height: 15px;" type="text"/>	<input style="width: 40px; height: 15px;" type="text"/>	<input style="width: 40px; height: 15px;" type="text"/>	<input style="width: 40px; height: 15px;" type="text"/>
COMMAND PERCENTAGE	<input style="width: 40px; height: 15px;" type="text"/>	<input style="width: 40px; height: 15px;" type="text"/>	<input style="width: 40px; height: 15px;" type="text"/>	<input style="width: 40px; height: 15px;" type="text"/>	<input style="width: 40px; height: 15px;" type="text"/>	<input style="width: 40px; height: 15px;" type="text"/>	<input style="width: 40px; height: 15px;" type="text"/>	<input style="width: 40px; height: 15px;" type="text"/>
ELAPSED TIME	0	<input style="width: 40px; height: 15px;" type="text"/>	<input style="width: 40px; height: 15px;" type="text"/>	<input style="width: 40px; height: 15px;" type="text"/>	<input style="width: 40px; height: 15px;" type="text"/>	<input style="width: 40px; height: 15px;" type="text"/>	<input style="width: 40px; height: 15px;" type="text"/>	<input style="width: 40px; height: 15px;" type="text"/>

FIGURE 14.1.2 TI ADJUSTMENT WORKSHEET

### 14.2 TEMPERATURE SENSOR CURVE

Only sensors with this Carel curve should be used with this system.

°C	°F	KΩ
-50.0	-58.0	329.20
-49.0	-56.2	310.70
-48.0	-54.4	293.30
-47.0	-52.6	277.00
-46.0	-46.0	261.80
-45.0	-49.0	247.50
-44.0	-47.2	234.10
-43.0	-45.4	221.60
-42.0	-43.6	209.80
-41.0	-41.8	198.70
-40.0	-40.0	188.40
-39.0	-38.2	178.30
-38.0	-36.4	168.90
-37.0	-34.6	160.10
-36.0	-32.8	151.80
-35.0	-31.0	144.00
-34.0	-29.2	136.60
-33.0	-27.4	129.70
-32.0	-25.6	123.20
-31.0	-23.8	117.10
-30.0	-22.0	111.30
-29.0	-20.2	105.70
-28.0	-18.4	100.40
-27.0	-16.6	95.47
-26.0	-14.8	90.80
-25.0	-13.0	86.39
-24.0	-11.2	82.22
-23.0	-9.4	78.29
-22.0	-7.6	74.58
-21.0	-5.8	71.07
-20.0	-4.0	67.74
-19.0	-2.2	64.54
-18.0	-0.4	61.52
-17.0	1.4	58.66
-16.0	3.2	55.93
-15.0	5.0	53.39
-14.0	6.8	50.96
-13.0	8.6	48.65
-12.0	10.4	46.48
-11.0	12.2	44.41
-10.0	14.0	42.25

°C	°F	KΩ
-9.0	15.8	40.56
-8.0	17.6	38.76
-7.0	19.4	37.05
-6.0	21.2	35.43
-5.0	23.0	33.89
-4.0	24.8	32.43
-3.0	26.6	31.04
-2.0	28.4	29.72
-1.0	30.2	28.47
0.0	32.0	27.23
1.0	33.8	26.13
2.0	35.6	25.03
3.0	37.4	23.99
4.0	39.2	22.99
5.0	41.0	22.05
6.0	42.8	21.15
7.0	44.6	20.29
8.0	46.4	19.40
9.0	48.2	18.70
10.0	50.0	17.96
11.0	51.8	17.24
12.0	53.6	16.55
13.0	55.4	15.90
14.0	57.2	15.28
15.0	59.0	14.68
16.0	60.8	14.12
17.0	62.6	13.57
18.0	64.4	13.06
19.0	66.2	12.56
20.0	68.0	12.09
21.0	69.8	11.63
22.0	71.6	11.20
23.0	73.4	10.78
24.0	75.2	10.38
25.0	77.0	10.00
26.0	78.0	9.63
27.0	80.6	9.28
28.0	82.4	8.94
29.0	84.2	8.62
30.0	86.0	8.31
31.0	87.8	8.01

°C	°F	KΩ
32.0	89.6	7.72
33.0	91.4	7.45
34.0	93.2	7.19
35.0	95.0	6.94
36.0	96.8	6.69
37.0	98.6	6.46
38.0	100.4	6.24
39.0	102.2	6.03
40.0	104.0	5.82
41.0	105.8	5.63
42.0	107.6	5.43
43.0	109.4	5.25
44.0	111.2	5.08
45.0	113.0	4.91
46.0	114.8	4.74
47.0	116.6	4.59
48.0	118.4	4.44
49.0	120.2	4.30
50.0	122.0	4.16
51.0	123.8	4.02
52.0	125.6	3.90
53.0	127.4	3.77
54.0	129.2	3.65
55.0	131.0	3.53
56.0	132.8	3.42
57.0	134.6	3.31
58.0	136.4	3.21
59.0	138.2	3.11
60.0	140.0	3.02
61.0	141.8	2.92
62.0	143.6	2.83
63.0	145.4	2.75
64.0	147.2	2.66
65.0	149.0	2.58
66.0	150.8	2.51
67.0	152.6	2.43
68.0	154.4	2.36
69.0	156.2	2.29
70.0	158.0	2.22
71.0	159.8	2.16
72.0	161.6	2.10

°C	°F	KΩ
73.0	163.4	2.04
74.0	165.2	1.98
75.0	167.0	1.92
76.0	168.8	1.87
77.0	170.6	1.81
78.0	172.4	1.76
79.0	174.2	1.71
80.0	176.0	1.66
81.0	177.8	1.62
82.0	179.6	1.57
83.0	181.4	1.53
84.0	183.2	1.49
85.0	185.0	1.45
86.0	186.8	1.41
87.0	188.6	1.37
88.0	190.4	1.33
89.0	192.2	1.30
90.0	194.0	1.26
91.0	195.8	1.23
92.0	197.6	1.20
93.0	199.4	1.16
94.0	201.2	1.13
95.0	203.0	1.10
96.0	204.8	1.08
97.0	206.6	1.05
98.0	208.4	1.02
99.0	210.2	0.99
100.0	212.0	0.97
101.0	213.8	0.94
102.0	215.6	0.92
103.0	217.4	0.90
104.0	219.2	0.87
105.0	221.0	0.85
106.0	222.8	0.83
107.0	224.6	0.81
108.0	226.4	0.79
109.0	228.2	0.77
110.0	230.0	0.75









## 15.0 GLOSSARY

### Analog Control Signal

An analog signal is a varying-voltage output signal, typically between 0–10 volts. It is most often used to produce a specific amount of output from a variable-output device, such as a digital scroll compressor or a variable speed fan. 0 volts would represent an OFF condition and 10 volts would represent a demand for output at 100% of capacity.

### BACnet

Building Automation Control Network. BACnet is a communications protocol for building automation and control networks. It is just one of several different control systems that may be used as part of a BMS.

### BACnet IP

### BACnet MSTP

BACnet Master Slave Token Passing—this is one of the possible BACnet protocols that may be used.

### BMS

A building management system (BMS) is a control system that can be used to monitor and manage the mechanical, electrical and electromechanical services in a facility. Such services can include power, heating, ventilation, air-conditioning, physical access control, pumping stations, elevators and lights.

### Cat-5 Cables

Cat-5 cable, sometimes called Ethernet cable, is short for Category 5 cable, a current industry standard for network wiring. This type of cable is unshielded wire containing four pairs of 24-gauge twisted copper pairs, terminating in an RJ-45 jack. If a wire is certified as Cat-5 and not just a twisted pair wire, it will have this designation printed on the outside.

### Controller

Direct Digital Control is the automated control of a condition or process by a digital device (computer). The controller accepts digital or analog inputs from a variety of sensors and then follows all of its programmed instructions to produce action instructions to valves, actuators, fans, compressors and other HVAC components that can be adjusted. The Carel controller is a DDC controller.

### Digital Control Signal

A digital control signal is a fixed-voltage or amperage output signal, representing either an “ON” or “OFF” condition for the device it is connected to. It is typically used to activate a relay that controls operation of a device.

### DIN Rail

A DIN rail is a specially shaped metal strip which is used to mount relays, switches, terminals, etc. in industrial panels. The shape of the strip is such that these items can be pressed onto it and a spring clip on each device slips into the bend in the rail and the device is held firmly. The strip can be mounted with screws or bolts to a wall or panel. The controller and any expansion boards are typically mounted on a DIN rail in the Main Control Panel.

### Economizer Bypass

The Economizer Bypass provides energy conservation during operation of an ERV. It accomplishes this by sensing ambient conditions and it then allows the return airstream or outdoor airstream to move through an alternate duct, bypassing the ERV enthalpic core when the unit calls for cooling and the outdoor conditions are more favorable than the return air.

### Ethernet

Ethernet is the standard way to connect computers on a network over a wired connection. It provides a simple interface and is used for connecting multiple devices, such as computers, routers, and switches. When the Carel controller is incorporated into a BMS, the BMS computer and the Carel controller become an ethernet.

### I/O Configuration

Refers to the specific wiring terminals on the controller that are assigned for each Input or OutputIP

### IP Address

A unique string of numbers separated by periods that identifies each computer using the Internet Protocol to communicate over a network

### Hot Gas Reheat (HGRH)

Used in dehumidification, hot gas reheat relies on an additional coil downstream of the cooling coil in which the hot refrigerant piping is in contact with the supply air. This allows a portion of the refrigerant cycle's rejected heat to be reclaimed as reheat. The amount of refrigerant piped to the coil is modulated to maintain a supply temperature during dehumidification.

### Hysteresis

The hysteresis is a value that is added to a setpoint for a specific control option to turn on, and then it turns off at setpoint. This helps prevent over cycling of the controlled device.

### I/O

Refers to all of the inputs and outputs such as sensors and control to fans.

### Modbus

Modbus is a serial communications protocol for use with programmable logic controllers (PLCs). It is a standard communication protocol, and it is now a commonly available means of connecting industrial electronic devices. Modbus enables communication among many devices connected to the same network, for example a system that measures temperature and humidity and communicates the results to a computer. Modbus is often used to connect a supervisory computer with a remote terminal unit (RTU) in supervisory control and data acquisition systems.

**Modbus RTU**—see Modbus, above.

**Modbus RTP**—see Modbus, above.

### NAND Memory

NAND flash memory is a type of non-volatile storage technology that does not require power in order to retain data. The technology is used in common storage devices such as flash drives, solid-state drives and memory cards.

**NODE**

Any system or device connected to a network is also called a node. For example, if a network connects a file server, five computers, and two printers, there are eight nodes on the network. Each device on the network has a network address, such as a MAC address, which uniquely identifies each device.

**PI Control**

The output of PID controllers will change in response to a change in process variable or setpoint.

**RJ-45 jack**

RJ-45 is a standard type of connector for network cables. RJ-45 connectors are most commonly seen with ethernet cables and networks. RJ-45 connectors feature eight pins to which the wire strands of a cable interface electrically. Standard RJ-45 pinouts define the arrangement of the individual wires needed when attaching connectors to a cable. Several other kinds of connectors closely resemble RJ-45 and can be easily confused for each other.

**RUT**

Remote User Terminal. The RUT is the User Interface where a person can view current operating conditions or status, make changes to setpoints and otherwise control the operation of the air handler. The Carel RUT is an electronic device that has multiple push buttons and a viewing screen and is connected to the Carel Controller by means of a common telephone cable.

**Setpoint**

The desired value in a closed-loop feedback system, as in regulation of temperature or pressure.

**USB/USB Port**

Universal Serial Bus. There are different types of USB ports that are commonly used. Type “A” ports are almost always found on computers and are used to connect with other electronic devices. The Carel c.pCO Mini has a Micro USB type “B” that is used to connect to external memory devices or to a computer.

**USB Thumb Drive**

A very small, portable, solid-state hard drive that can be inserted into a USB port for storage and retrieval of data.

**UI**

User Interface—commonly called “UI.” A user interface is the means by which a person controls a hardware device or a software application. For the Carel Controller, the RUT (Remote User Terminal) is one possible User Interface.

**URL**

Uniform Resource Locator. Commonly referred to as a web address. It is a very specific address that identifies the location of a specific website or address on the internet.

**Wipe Retain**

Wipe/Retain is a user-commanded function in which all non-volatile memory in the Controller is erased and factory defaults are reinstalled.



## About RenewAire

For over 40 years, **RenewAire has been a pioneer in enhancing indoor air quality (IAQ)** in commercial and residential buildings of every size. This is achieved while maximizing sustainability through our fifth-generation, static-plate, enthalpic-core **Energy Recovery Ventilators (ERVs) that optimize energy efficiency**, lower capital costs via load reduction and decrease operational expenses by minimizing equipment needs, resulting in significant energy savings. Our ERVs are competitively priced, simple to install, easy to use and maintain and have a quick payback. They also enjoy the industry's best warranty with the lowest claims due to long-term reliability derived from innovative design practices, expert workmanship and **Quick Response Manufacturing (QRM)**.

As the pioneer of static-plate core technology in North America, RenewAire is the largest ERV producer in the USA. We're **committed to sustainable manufacturing** and lessening our environmental footprint, and to that end our Waunakee, WI plant is 100% powered by wind turbines. The facility is also one of the few buildings worldwide to be LEED® Gold and Green Globes certified, as well as having achieved ENERGY STAR Building status. In 2010, RenewAire joined the Soler & Palau (S&P) Ventilation Group in order to provide direct access to the latest in energy-efficient air-moving technologies. For more information, visit: [renewaire.com](http://renewaire.com)

201 Raemisch Road | Waunakee, WI | 53597 | 800.627.4499 | [RenewAire.com](http://RenewAire.com)