

Shipping, Rigging, Hoisting, and Assembly Manual

Supplemental Installation Manual for Units

LE-5X
LE-6X
LE-8X
LE10X



⚠ WARNING

RISK OF DEATH OR SERIOUS INJURY

Hoisting heavy equipment overhead is inherently dangerous. Failure to properly rig the ERV for hoisting or the use of incorrect rigging equipment may result in the ERV falling during hoisting.

Improper work procedures may result in death or serious injury to workers. Rigging, hoisting and assembly are to be performed by skilled and experienced personnel. OSHA-approved work guidelines are to be strictly followed.

Before proceeding with installation, read all instructions, verifying that all the parts are included.

The information in this manual is provided as a guideline and does not necessarily meet all local codes. It is the installer's responsibility to comply with all local codes and OSHA-approved safety practices.

⚠ CAUTION

RISK OF DAMAGE TO ENTHALPIC CORES

Whenever working within the ERV cabinet, protect the enthalpic cores from accidental damage. The core media is subject to damage from dropped tools or other foreign objects.

⚠ CAUTION

RISK OF DAMAGE TO ERV CABINET

Incorrect lifting can cause damage to the unit.

Do not lift joined unit by the 4 corner lifting lugs only. Secure lifting cables to the center lifting lugs also.

All lifting lugs provided must be used. Never lift the unit or modules from the top of the unit.

⚠ CAUTION

This unit is for ventilating finished structures only. It is not to be used until after all construction has been completed and construction debris and dust are cleaned from the Occupied Space.

⚠ CAUTION

This unit is intended for general ventilating only. Do not use to exhaust hazardous or explosive materials and vapors. Do not connect this equipment to range hoods, fume hoods or collection systems for toxics.

⚠ CAUTION

Do not lift joined unit by the 4 corner lifting lugs only. Secure lifting cables to the center lifting lugs also.

All lifting lugs provided must be used. Never lift the unit or modules from the top of the unit.

Incorrect lifting can cause damage to the unit.

⚠ CAUTION

This equipment is to be installed by following Industry Best Practices and all applicable codes. Any damage to components, assemblies, subassemblies or the cabinet which is caused by improper installation practices will void the warranty.

IMPORTANT

If this unit is installed in an area where it may draw air from a nearby fuel-burning device such as a gas furnace or water heater, verify that the air being extracted by the ERV does not conflict with proper operation of the fuel-burning device.

IMPORTANT

This unit can be delivered in two modules for on-site assembly or as a completely assembled unit (additional charges apply). See separate unit-specific Installation, Operation and Maintenance manual for further information.

1.0 SHIPPING	6	7.0 INDOOR UNIT DIMENSIONS	24
1.1 RECEIVING AND HANDLING	6	7.1 LE5XINH DIMENSION DRAWING	24
1.2 STORAGE BEFORE INSTALLATION	6	7.2 LE5XINV DIMENSION DRAWING.....	24
2.0 RIGGING	7	7.3 LE6XINH DIMENSION DRAWING	25
2.1 REQUIRED RIGGING EQUIPMENT	7	7.4 LE6XINV DIMENSION DRAWING.....	25
3.0 FORKLIFT REQUIREMENTS	9	7.5 LE8XINH DIMENSION DRAWING	26
4.0 MODULE ASSEMBLY	9	7.6 LE8XINV DIMENSION DRAWING.....	26
4.1 CONFIGURATION LABEL	9	7.7 LE10XINH DIMENSION DRAWING	27
4.2 ASSEMBLY PREPARATION	9	7.8 LE10XINV DIMENSION DRAWING.....	27
4.3 REMOVE SHIPPING STRAPS	10	8.0 LE5X CORNER WEIGHTS	28
4.4 APPLY FOAM GASKET TAPE.....	10	8.1 LE5XRT CORNER WEIGHTS	28
4.5 JOIN MODULES TOGETHER	10	8.2 LE5XINH CORNER WEIGHTS	29
4.5.1 Bolt Together at Lifting Lugs	11	8.3 LE5XINV CORNER WEIGHTS	29
4.5.2 Bolt Together Mating Roof Beams	12	9.0 LE6X CORNER WEIGHTS	30
4.5.3 Caulk The Seams.....	13	9.1 LE6XRT CORNER WEIGHTS	30
4.5.4 Install Joining Roof Cap	13	9.2 LE6XINH CORNER WEIGHTS	31
4.5.5 Install Assembly Straps	14	9.3 LE6XINV CORNER WEIGHTS	31
4.5.6 Install Roof End Joining Caps.....	14	10.0 LE8X CORNER WEIGHTS	32
4.6 CONNECT THE WIRING HARNESS	15	10.1 LE8XRT CORNER WEIGHTS	32
4.7 INSTALL WEATHERHOODS	16	10.2 LE8XINH CORNER WEIGHTS	33
4.8 INSTALL MERV-8 FILTERS.....	17	10.3 LE8XINV CORNER WEIGHTS	33
5.0 ROOFTOP CURB DIMENSIONS	18	11.0 LE10X CORNER WEIGHTS	34
5.1 LE5XRT CURBS.....	18	11.1 LE10XRT CORNER WEIGHTS.....	34
5.2 LE6XRT CURBS.....	18	11.2 LE10XINH CORNER WEIGHTS	35
5.3 LE8XRT CURBS.....	19	11.3 LE10XINV CORNER WEIGHTS	35
5.4 LE10XRT CURBS.....	19		
6.0 ROOFTOP UNIT DIMENSIONS	20		
6.1 LE5XRTH-F DIMENSION DRAWING	20		
6.2 LE5XRTV-R DIMENSION DRAWING	20		
6.3 LE6XRTH-F DIMENSION DRAWING	21		
6.4 LE6XRTV-R DIMENSION DRAWING	21		
6.5 LE8XRTH-F DIMENSION DRAWING	22		
6.6 LE8XRTV-R DIMENSION DRAWING	22		
6.7 LE10XRTH-F DIMENSION DRAWING	23		
6.8 LE10XRTV-R DIMENSION DRAWING	23		

TABLE OF ILLUSTRATIONS

Figure 1.1.0 LE ERV Hood Shipping Location (typ)	6
Figure 2.1.0 Rigging Assembly Graphic 1	8
Figure 2.1.1 Rigging Assembly Graphic 2	8
Figure 2.1.2 Corner Lifting Lug (typ)	8
Figure 4.3.0 Shipping Straps Location	10
Figure 4.4.0 Foam Gasketing Tape Location (typ)	10
Figure 4.5.0 Module Joining	11
Figure 4.5.1 LE Indoor Unit Base Bolt Locations	11
Figure 4.5.2 LE Rooftop Unit Base Bolt Locations	11
Figure 4.5.3 Roof Beam Assembly Graphic 1	12
Figure 4.5.4 Roof Beam Assembly Graphic 2	12
Figure 4.5.5 Roof Beam Assembly Bolt Locations	12
Figure 4.5.6 Roof Beam Caulking	13
Figure 4.5.7 Roof Cap Caulking	13
Figure 4.5.8 Assembly Strap Information	14
Figure 4.5.9 Roof End Joining Caps	14
Figure 4.6.0 Wire Harness Details	15
Figure 4.6.1 Wire Harness Details Continued	15
Figure 4.6.2 Access Panel Installation	16
Figure 4.7.0 Outside Air Hood Installation	16
Figure 4.7.1 Exhaust Air Hood Installation	16
Figure 4.9.0 Filter Spacers	17
Figure 4.9.1 Filter Racks	17

1.0 SHIPPING

All ERVs are palletized and then shipped by common carrier. It is the installer's/customer's responsibility to coordinate delivery and properly handle the shipment during unloading and storage.

1.1 RECEIVING AND HANDLING

Upon delivery of the ERV, inspect it carefully for shipping damage and completeness. Verify the presence of any accessories such as external hoods that are to be field-installed or filters that are shipped loose. If shipping damage is discovered, take digital pictures and note the visible damage on the shipping manifest. Notify your RenewAire dealer immediately.

Note that whenever possible, accessories such as weather hoods are assembled and then secured for shipping inside the ERV. *See photo below.*

HOODS ARE ASSEMBLED AT THE FACTORY AND THEN SECURED FOR SHIPMENT INSIDE THE ERV.

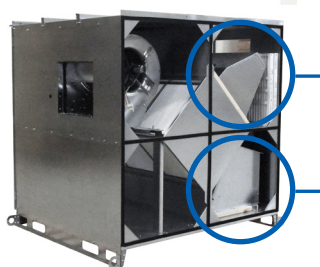

FIGURE 1.1.0 LE ERV HOOD SHIPPING LOCATION (TYP)

LE-5X models are a single module and are delivered as a completely assembled unit. LE-6X, LE-8X, and LE10X models can be delivered in two modules for on-site assembly or as a complete unit (additional charges apply).

In all cases, extra protective pallet materials may have been added; this material was added at the factory to protect the unit or modules during shipping.

In all cases, when shipped as modules, assembly materials ship loose and can be found inside the modules. Note that assembly materials must be removed and installed prior to unit operation.

For rooftop models, the outdoor air weather hoods ship loose and can be found inside the modules. Note that weather hoods and assembly materials must be removed and installed prior to unit operation.

1.2 STORAGE BEFORE INSTALLATION

If installation will not occur immediately following delivery, store equipment in a dry protected area away from construction traffic and in the proper orientation as marked on the packaging with all internal packaging in place.

When placing the ERV on the ground, the placement area should be flat and level. Take care to avoid twisting or wracking of the unit.

2.0 RIGGING

Assembled LE-6X, LE-8X and LE10X units come equipped with base rail lifting lugs at the lower 4 corners and in the middle of the unit. LE-5X units and other individual module sections come equipped with base rail lifting lugs at the lower 4 corners.

Each lifting lugs come equipped with a 2" diameter hole which will accommodate a 1.5" dia. schedule 40 steel pipe (not provided).

Unit or module sections shall be lifted by cables attached to all of the lifting lugs.

If cables or chains are used to lift the unit they must be the same length. Care should be taken not to damage the cabinet, dampers, or electrical box.

Adjustable spreader bars should be used to properly support the unit in order to properly distribute the load thus applying an even vertical lifting force to all of the lifting lugs. This will prevent structural damage to the unit.

Also adjustable spreader bars should be used to maintain the required 10" clearance between the cables and the cabinet or any of the equipment attached to the unit or modules.

Provide additional blocking or covering as required.

Secure hooks and cables at all lifting points.

Take up slack in cables gradually as to avoid sudden movements as this may cause the unit or modules to shift.

Suspending the unit or modules for an extended period of time is not recommended and it is advised to place the unit as soon as possible after lifting.

Do not lift in high winds.

RenewAire will not be responsible for any damage during the rigging, lifting or installing of the unit or modules.

Refer to Corner Weight Charts for exact center of gravity.

2.1 REQUIRED RIGGING EQUIPMENT

All rigging equipment is to be provided by the installing Contractor.

Rigging procedures may differ depending on the physical dimensions of the unit or modules, its location, the job site, or Installing Contractor preferences.

Tools needed (Suggested):

- Crane to lift proper capacity
- Adjustable spreader bars
- Cables
- 1.5" Dia. steel pipe schedule 40.
- Tools to pull modules together, chains, bar clamps, come alongs etc.
- Miscellaneous (SAE) wrenches and 1/2" drive socket wrenches with short extensions

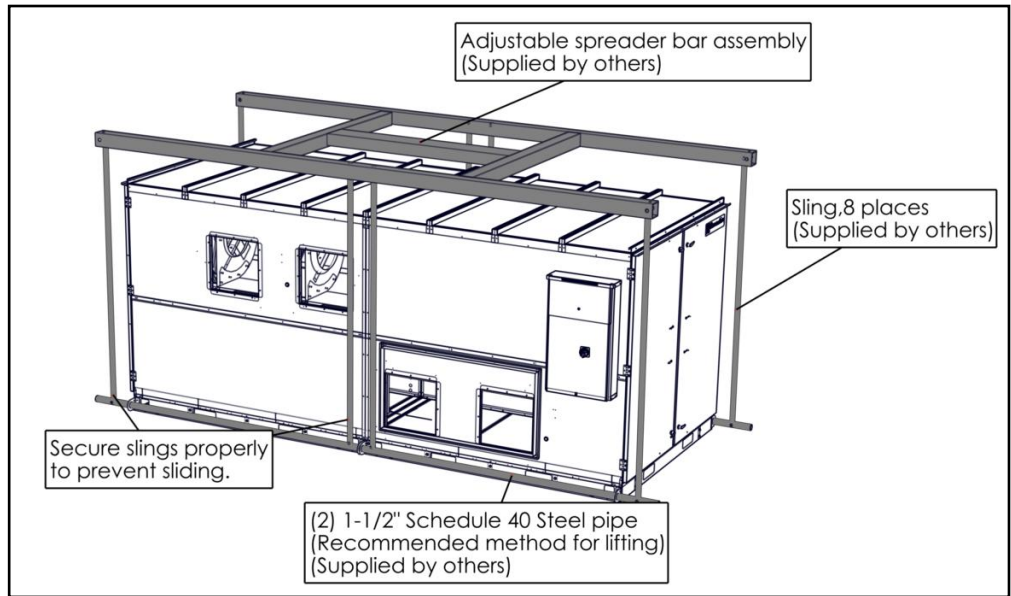

FIGURE 2.1.0 RIGGING ASSEMBLY GRAPHIC 1

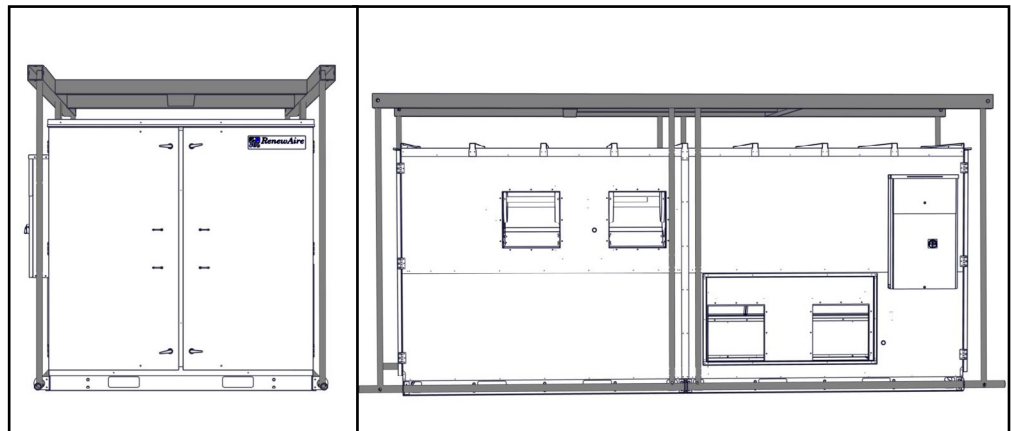

FIGURE 2.1.1 RIGGING ASSEMBLY GRAPHIC 2



FIGURE 2.1.2 CORNER LIFTING LUG (TYP)

3.0 FORKLIFT REQUIREMENTS

When lifting individual modules, forklift extensions must be used and a minimum length of 72" (96" preferred).

When lifting modules off the pallets:

If entering from the door side or the open side of the module ensure forks extend in far enough as to catch the furthest away stringer with fork extensions.

If entering from the side of the module, insure forks extend all the way through the module.

IMPORTANT

Do not attempt to lift a rooftop module off the pallet from the door side or open side as there are no stringers under the unit to carry the load.

Assembled modules should never be lifted using a forklift.

4.0 MODULE ASSEMBLY

4.1 CONFIGURATION LABEL

RenewAire LE-6X, LE-8X and LE10X ERVs can either be built and shipped factory assembled or be ordered unassembled for applications where modules must be manipulated separately. If the unit was ordered unassembled, then you will need to assemble the modules in the field.

Each module is labeled with a configuration and serial number label. Locate these labels and insure each module assembled together have the same configuration and serial number. *See the image on page 3 of this manual.*

If for any reason you are unable to identify a module or its position in the final assembly, then consult the Installation Contractor or RenewAire Customer Service.

4.2 ASSEMBLY PREPARATION

Extra protective pallet material has to be removed prior to assembly. This additional pallet material was added at the factory to protect the unit during shipping.

Also, plywood protective packaging material has to be removed from modules before assembly.

It is desirable to situate all required modules in the installation location as near as possible to the order in which they will be connected. Be sure to leave enough space to work between modules before connection. Gasket tape will be applied before assembling the modules.

All materials for assembling the modules are supplied by RenewAire.

4.3 REMOVE SHIPPING STRAPS

Remove shipping straps from opening/mating ends before joining modules and operating the unit. Shipping straps are attached to the modules at the factory. These straps insure proper rigidity when shipping and lifting. Once the straps are removed they may be disposed of along with the screws that held them in place.

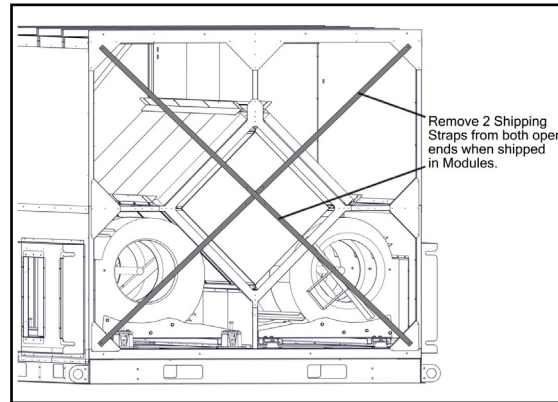

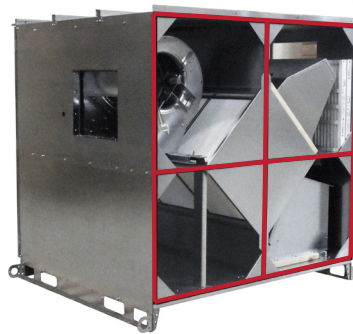

FIGURE 4.3.0 SHIPPING STRAPS LOCATION

4.4 APPLY FOAM GASKET TAPE

Apply 1/2" X 1" gasket tape (provided), as shown below. Gasket tape creates an airtight seal between modules. The adhesive backing on the gasket tape is easily repositioned during assembly if needed. However, if gasket tape is allowed to set more than 48 hours, it will be difficult to reposition.

 NOTE: Failure to apply foam gasketing tape as shown here will compromise water and airtight seal of the unit.



INSTALL FOAM GASKETING TAPE AS SHOWN HERE.
(GASKETING IS SHOWN IN RED FOR CLARITY)

FIGURE 4.4.0 FOAM GASKETING TAPE LOCATION (TYP)

4.5 JOIN MODULES TOGETHER

Align modules and push together using forklift or other means, compressing the gasket tape. The lower lifting lugs are equipped with 2" diameter holes that 1.5" dia. (2" OD) steel pipe could be used to assist in alignment. *See Lifting Lug illustration on page 8 of this manual.* Joining lift lugs also have a spacing bolt at the tip of one lug that will fit into the empty lug hole of the other module for alignment and lug tip spacing.



MODULE POSITIONING TECHNIQUE

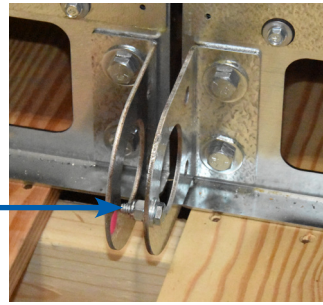

ALIGNMENT/
SPACER BOLT

ALIGNMENT/SPACER BOLT LOCATION

FIGURE 4.5.0 MODULE JOINING

4.5.1 Bolt Together at Lifting Lugs

After positioning the modules together, compressing the gasket tape, insert eight 3/8" - 16 x 1-1/4 plated hex head bolts through the holes on the lifting lugs and base rail (LE-IN) or base supports (LE-RT) of the two adjacent modules. Use 3/8" washers between the bolt head and the unit and between the nut and the unit. Fasten the nuts to the bolts secure the bases of the two modules together tightly.

LE Indoor Units:

Install 2 bolts in the mating lifting lugs and then 2 more bolts in the mating base rails. typical each side of LE unit.

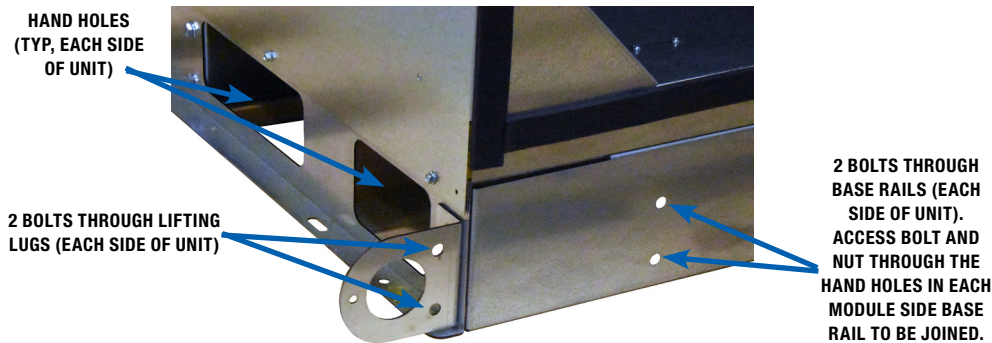

FIGURE 4.5.1 LE INDOOR UNIT BASE BOLT LOCATIONS

LE Rooftop Units:

Install 2 bolts in the mating lifting lugs and then 2 more bolts in base support.

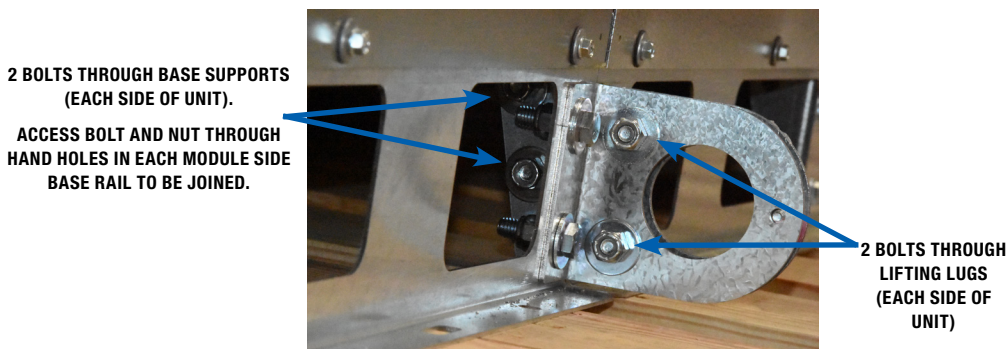

FIGURE 4.5.2 LE ROOFTOP UNIT BASE BOLT LOCATIONS

4.5.2 Bolt Together Mating Roof Beams

Use bar clamps, or other non-destructive winching device to pull the top of the modules together tightly compressing the gasket. After aligning the 4 roof bolt locations, insert 1/4" - 20 x 1.00" Grade 5 zinc plated hex head bolts through the holes in the roof beam. Secure the nuts to secure the roof section.



AFTER THE LIFTING LUG ASSEMBLIES HAVE BEEN BOLTED TOGETHER, RAISE ONE END OF THE UNIT TO COMPRESS THE GASKETING AND BRING BOTH OF THE MATING ROOF BEAMS INTO TIGHT CONTACT.

FIGURE 4.5.3 ROOF BEAM ASSEMBLY GRAPHIC 1

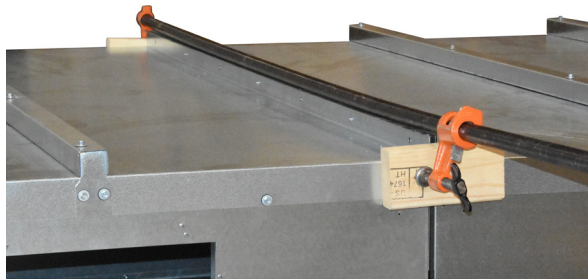

USE A PIPE CLAMP TO ADJUST THE ROOF BEAMS LATERALLY AND THEN BOLT TOGETHER THE TWO ROOF BEAMS.

FIGURE 4.5.4 ROOF BEAM ASSEMBLY GRAPHIC 2

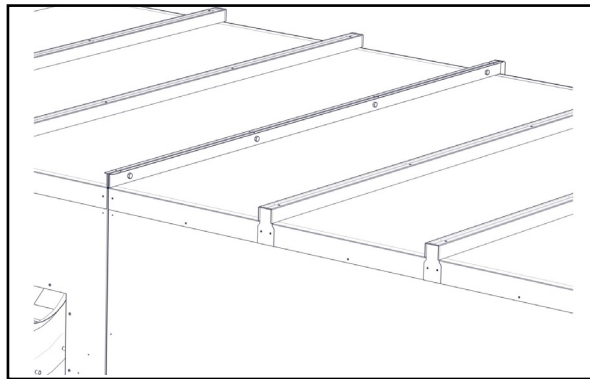

FIGURE 4.5.5 ROOF BEAM ASSEMBLY BOLT LOCATIONS

SHIPPING, RIGGING, LIFTING, AND ASSEMBLY: LE MODELS **ERV**

4.5.3 Caulk The Seams

Attention should be taken to assure the modules are forming an air and water tight seal.

Apply a continuous ½" bead of Tremsil 600 Silicone Sealant caulk (provided) at the seam along the entire roof and sides of the unit.

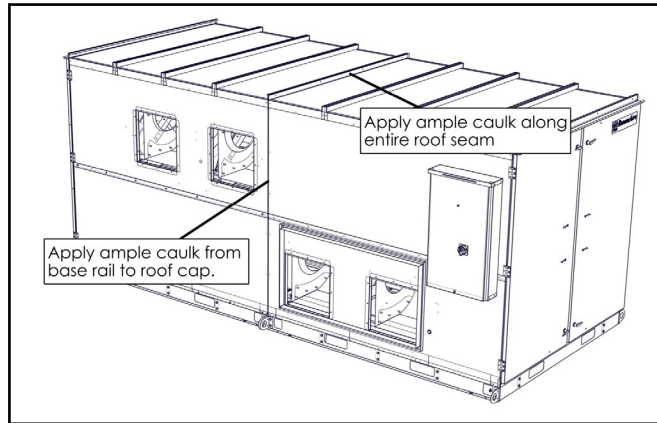

FIGURE 4.5.6 ROOF BEAM CAULKING

NOTE: Failure to apply caulk in these locations will compromise the water and airtight seal of the unit.

4.5.4 Install Joining Roof Cap

A galvanized cap roof flange is provided to seal the roof seam and to maintain a water and airtight seal. The cap roof flange is provided with pre-drilled holes. #12 X 3/4" hex head tek screw w/washers are provided to attach the cap roof flange.

For best results, use a lower torque setting on the power drill. Be careful not to over tighten the screw.

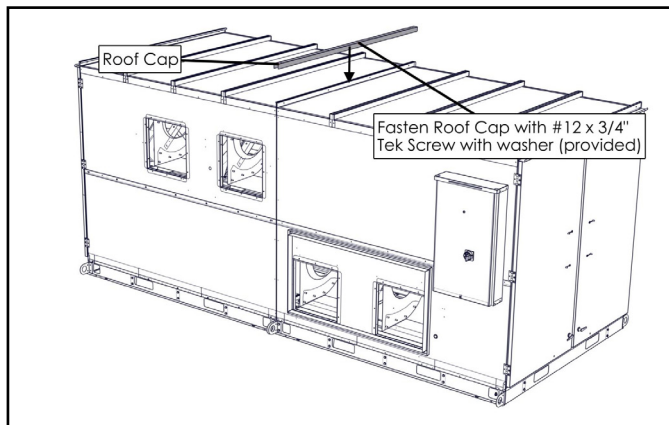

FIGURE 4.5.7 ROOF CAP CAULKING

NOTE: Failure to install the roof cap will compromise the water and airtight integrity of the unit.

4.5.5 Install Assembly Straps

Two (2) galvanized metal assembly straps are used to secure the module seams to assist in maintaining a water and airtight seal and provide structural rigidity during lifting. One (1) used on each side of the unit. These straps are provided with pre-drilled holes. #12 X 3/4" hex head tek screw w/washers are provided to attach the joining straps to the unit. For additional protection, caulk sides of straps after attachment.

For best results, use a lower torque setting on the power drill. Be careful not to over tighten the screw.

NOTE: Failure to install the assembly straps will compromise the structural integrity of the unit and cause damage during lifting. It will also compromise the water and airtight integrity of the unit.

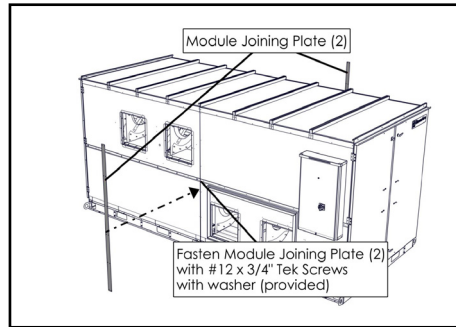

ASSEMBLY STRAP LOCATIONS

ASSEMBLY STRAP INSTALLATION

FIGURE 4.5.8 ASSEMBLY STRAP INFORMATION

4.5.6 Install Roof End Joining Caps

Two (2) galvanized roof cap ends are provided to seal the top end of each module and maintain a water and airtight seal. The roof cap joining ends are provided with pre-drilled holes. #12 X 3/4" hex head tek screw w/washers are provided to attach these roof cap joining ends to the unit.

NOTE: Failure to install roof cap ends will compromise the structural integrity of the unit and cause unit damage during lifting. It will also compromise the water and airtight integrity of the unit.

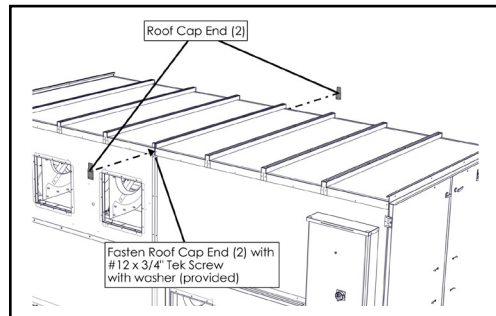

FIGURE 4.5.9 ROOF END JOINING CAPS

SHIPPING, RIGGING, LIFTING, AND ASSEMBLY: LE MODELS **ERV****4.6 CONNECT THE WIRING HARNESS**

Internal wiring connections are required after modules are fastened together, and before connection of unit supply power. For INH and RT models, the back module comes pre-wired with the exhaust air blower wires being routed from the motor to the open end of the module. The wiring harnesses end in plugs, ready for connection.

If the back module is equipped with isolation dampers, they are also pre-wired with the damper wires being routed from the damper actuators to the open end of the module. The ends of the damper wiring harnesses also end in plugs, ready for connection.

After the modules are joined together, open the electrical connection cover on the E-Box side of the front module by removing screws in the access panel. The access panel is located in the upper left corner of the front module, to the left of the E-Box.

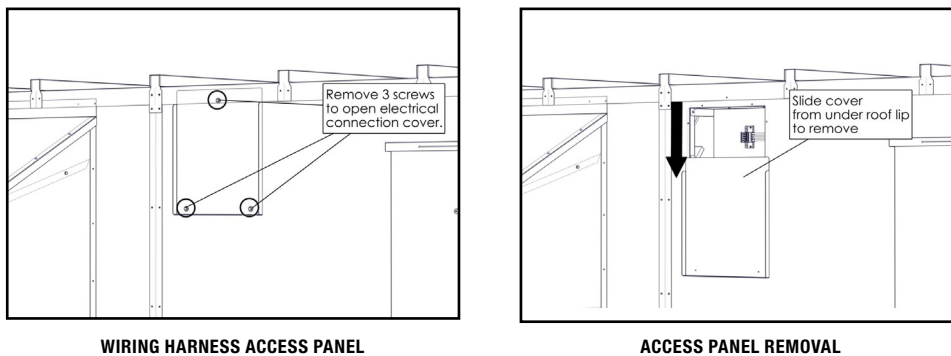

FIGURE 4.6.0 WIRE HARNESS DETAILS

Inside the access panel are low voltage and high voltage wiring connection compartments. The low voltage compartment is the lower compartment and the high voltage compartment is the upper compartment. Both compartments are open on the left side to access the wiring harness plugs or wires terminated with ferrules that are coming from the exhaust air blower and isolation dampers (if equipped).

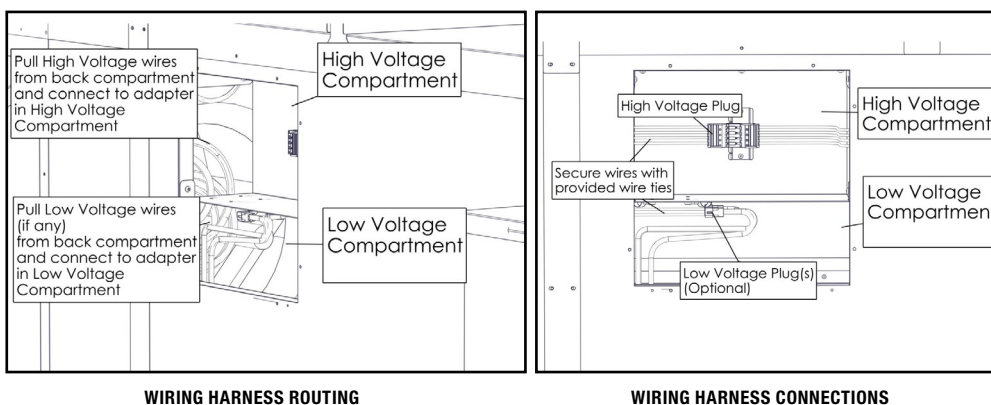

FIGURE 4.6.1 WIRE HARNESS DETAILS CONTINUED

Reach through the open left side of the compartments and into the rear module. Guide the wiring harness(es) or wires into the wiring connection compartments in the front module. Plug each wiring harness into its matching connector or attach wires to color coded terminal blocks matching the wire colors to the terminal block colors, located in the wiring connection compartments. Secure excess wire with wire ties.

Replace the access cover by sliding the top edge of the cover behind the edge of the roof pan and replace the screws. Caulk the sides and bottom of the access panel with factory-supplied caulk.

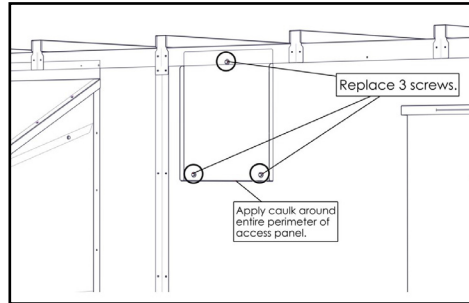

FIGURE 4.6.2 ACCESS PANEL INSTALLATION

4.7 INSTALL WEATHERHOODS

Rooftop units (RT models) have weatherhoods that are shipped loose and must be field-installed. Installation of the hoods is normally performed after all rigging and hoisting is completed because of the chance of damage to the hoods by the rigging equipment.

All weatherhoods have a flange on the top rear that must be inserted behind the roof panel overhang. To install any hood, remove the factory-installed roof edge screws and keep them for re-use.

Outside Air Hoods:

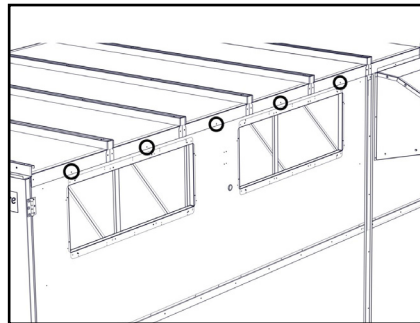

OA HOOD SCREW LOCATIONS

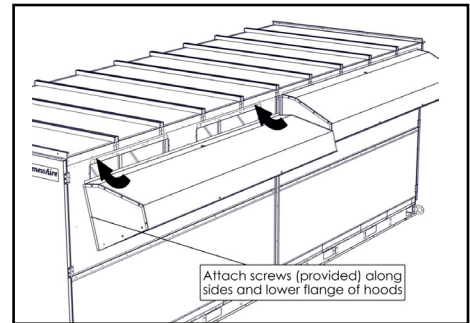

OA HOOD INSTALLATION

FIGURE 4.7.0 OUTSIDE AIR HOOD INSTALLATION

Slide the top flange of the OA air hood beneath the roof panel overhang. Reinstall the screws in the roof edge and then install screws along the sides and lower edge of each hood.

Exhaust Air Hoods:

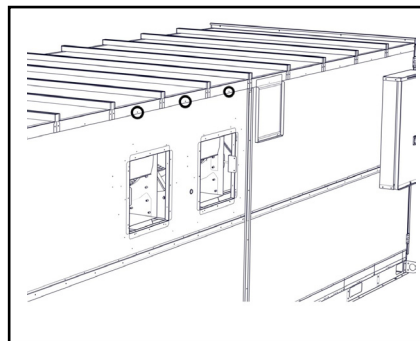

EA HOOD SCREW LOCATIONS

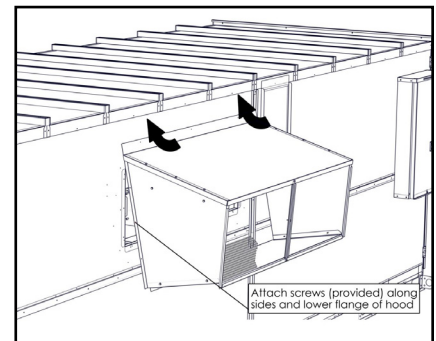

EA HOOD INSTALLATION

FIGURE 4.7.1 EXHAUST AIR HOOD INSTALLATION

Slide the top flange of the EA air hood beneath the roof panel overhang. Reinstall the screws in the roof edge and then install screws along the sides and lower edge of each hood.

4.8 INSTALL MERV-8 FILTERS

LE units ship with 20" X 25" X 2" (nominal) MERV 8 air filters. Filters are shipped loose in LE-RT units or may be installed prior to shipment in LE-IN units. In addition, RenewAire provides a set of filter spacers and a filter extractor hook, all shipped loose.

The filter spacers have a tab on the ends where a pull cord can be inserted. With a cord installed in the tab holes, it is possible to simply pull the cords and withdraw all the filters in a filter bank at once. See image below. When installing the filter spacers, the foam strip is to be placed against the filter.

Note that when filters are installed, the filter spacers may tend to fall off the end of the filter receiving channels. If this happens, simply install the spacers between the first two filters in from the door., instead of locating them against the access doors.

Install filters in filter racks with airflow direction arrow on filters correctly oriented. The short sides of the filter will slide in the filter channels.

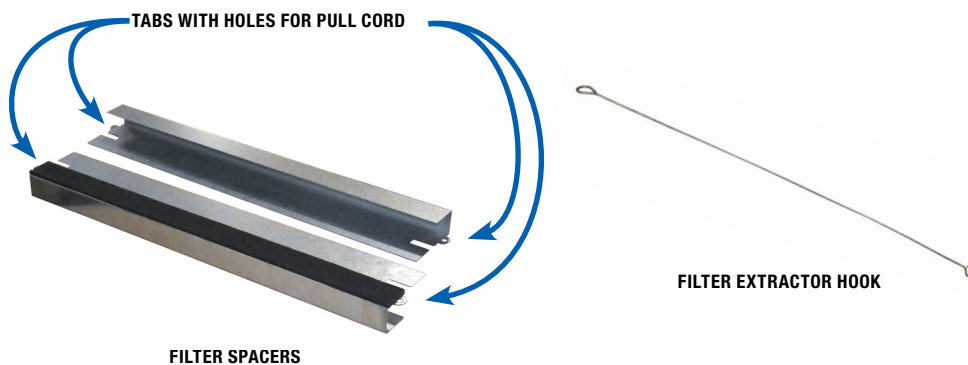

FIGURE 4.9.0 FILTER SPACERS

RenewAire recommends that the factory-provided MERV-8 filters be installed immediately and be kept in place during the construction and installation phases. Once the unit is fully installed, the filters may be changed to the desired efficiency and thickness. *See the unit-specific manual for filter changing options and procedures.*

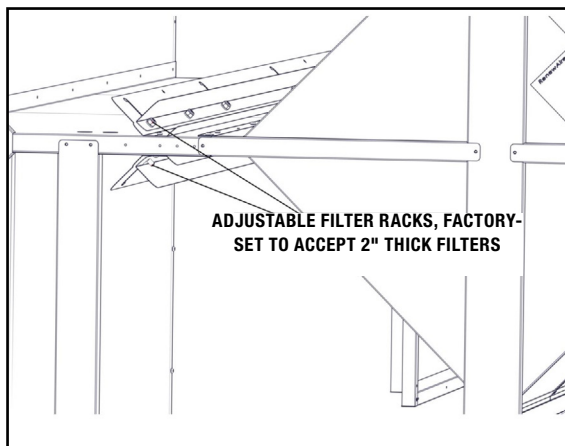

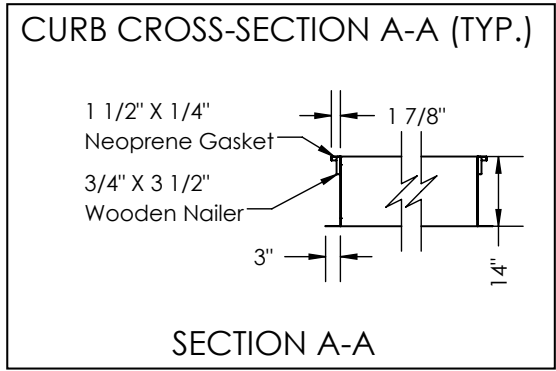

FIGURE 4.9.1 FILTER RACKS

5.0 ROOFTOP CURB DIMENSIONS

 **NOTE:** See Curb Clip Installation Manual and Curb Clips Design Notes document for LE-RT suggested installation instructions on a rooftop curb.



5.1 LE5XRT CURBS

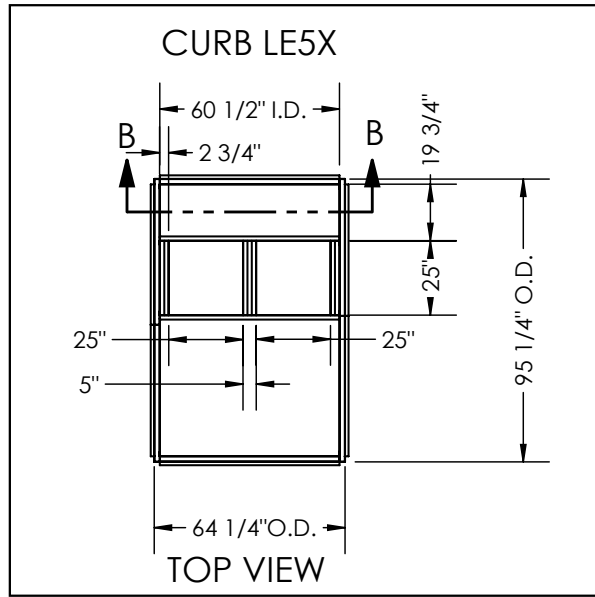

5.2 LE6XRT CURBS

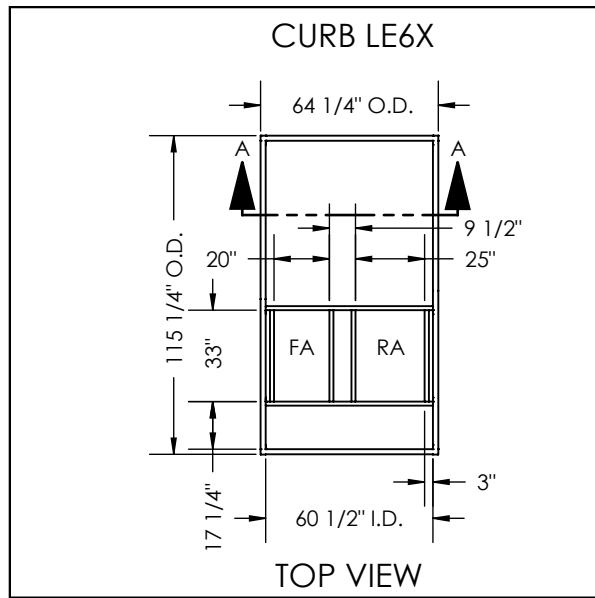

5.3 LE8XRT CURBS

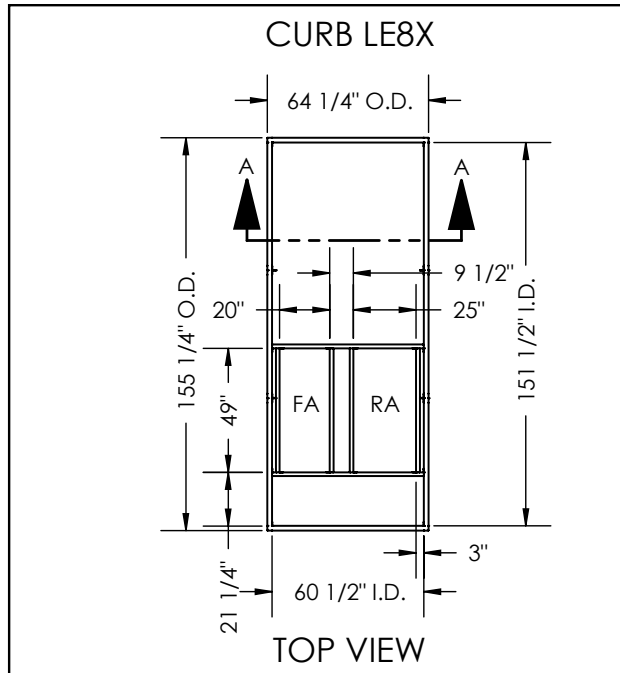

5.4 LE10XRT CURBS

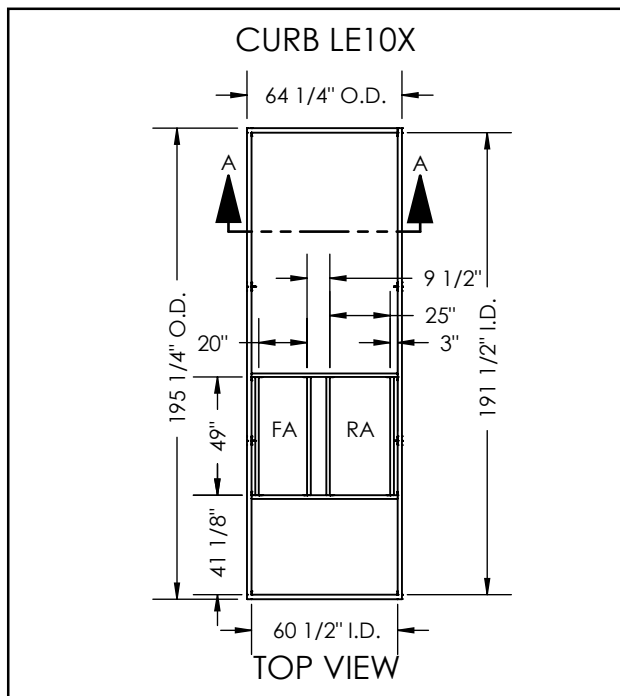

6.0 ROOFTOP UNIT DIMENSIONS

6.1 LE5XRTH-F DIMENSION DRAWING

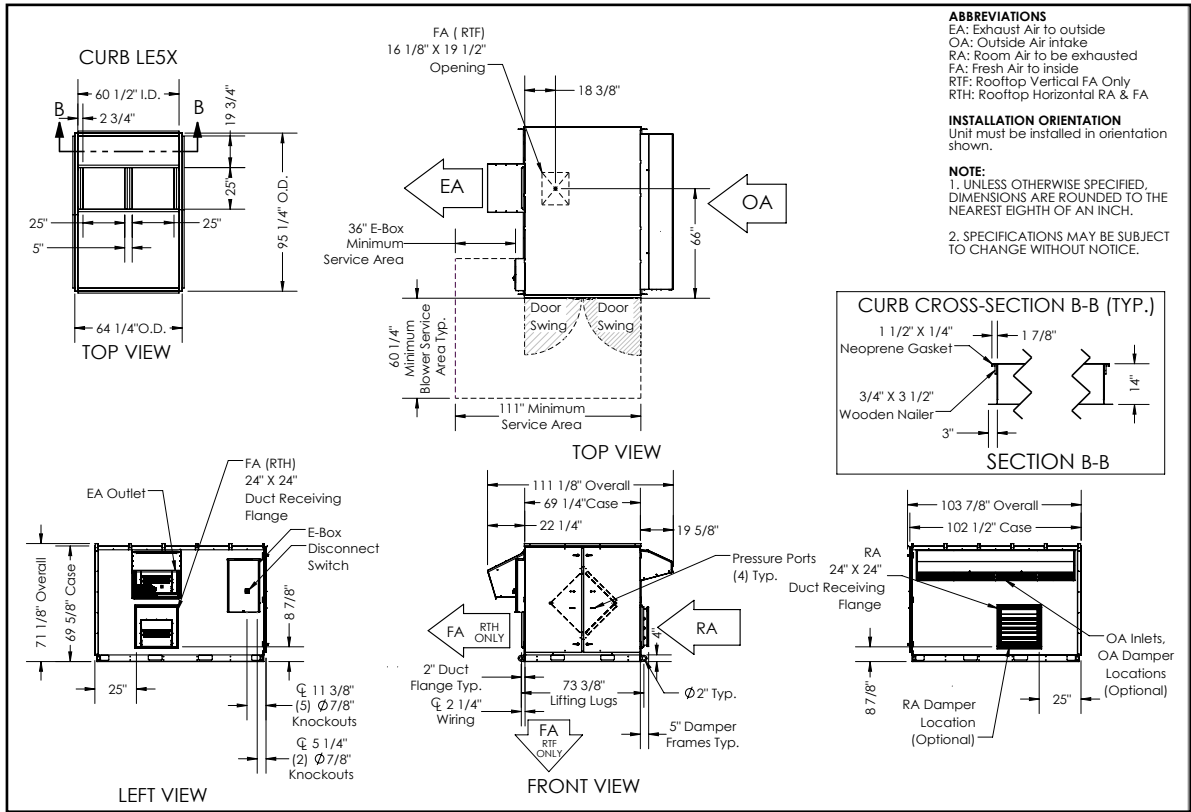

6.2 LE5XRTH-R DIMENSION DRAWING

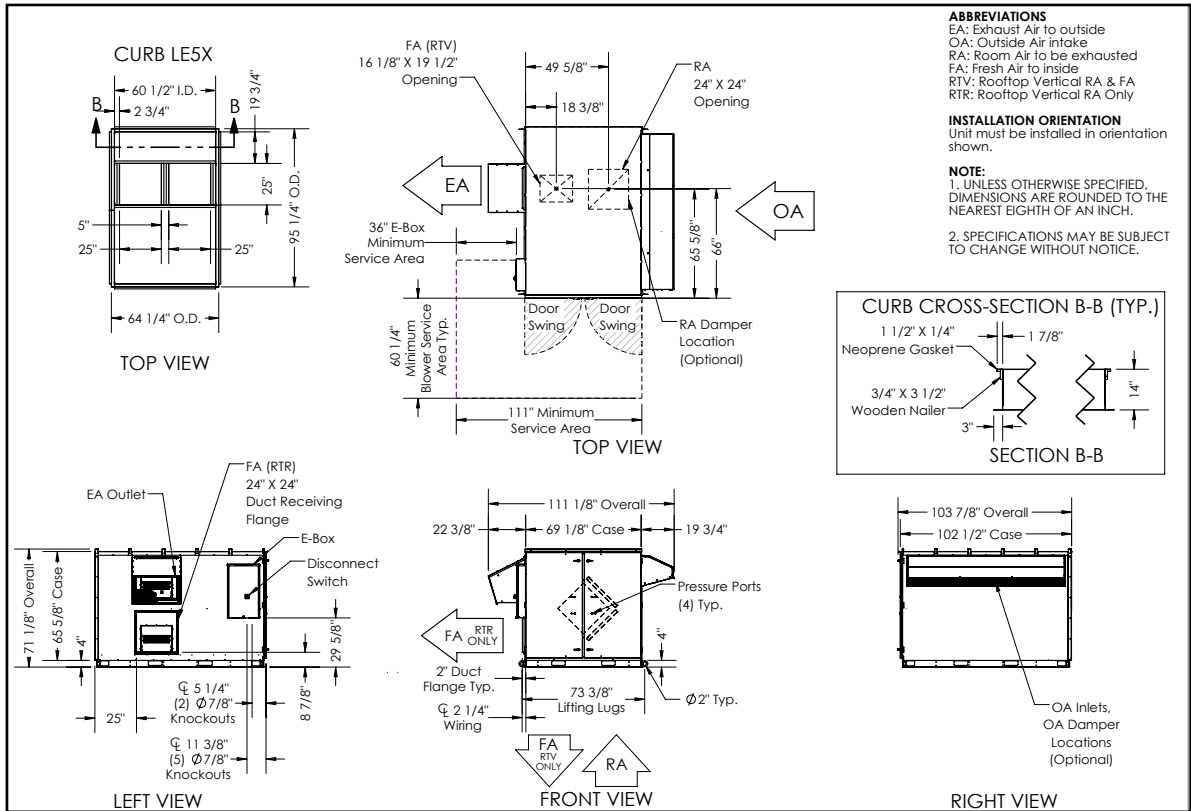

SHIPPING, RIGGING, LIFTING, AND ASSEMBLY: LE MODELS **ERV**

6.3 LE6XRTH-F DIMENSION DRAWING

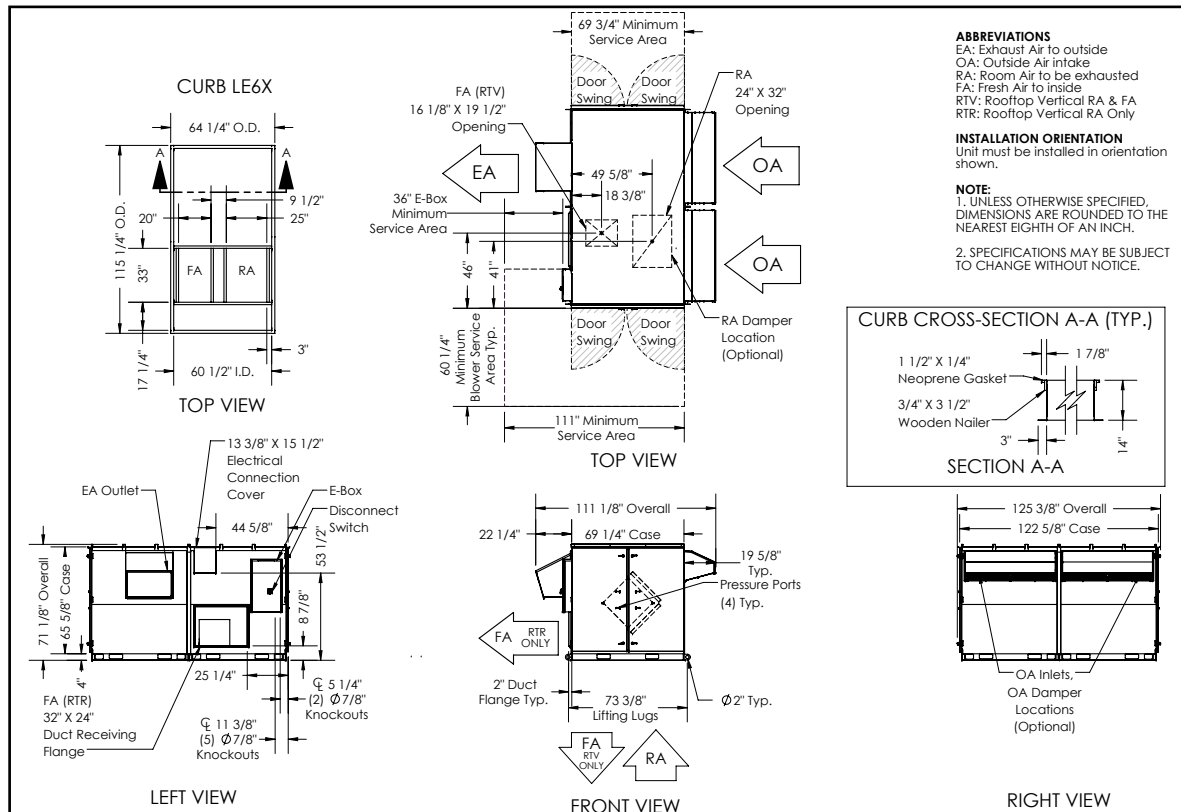

6.4 LE6XRTH-R DIMENSION DRAWING

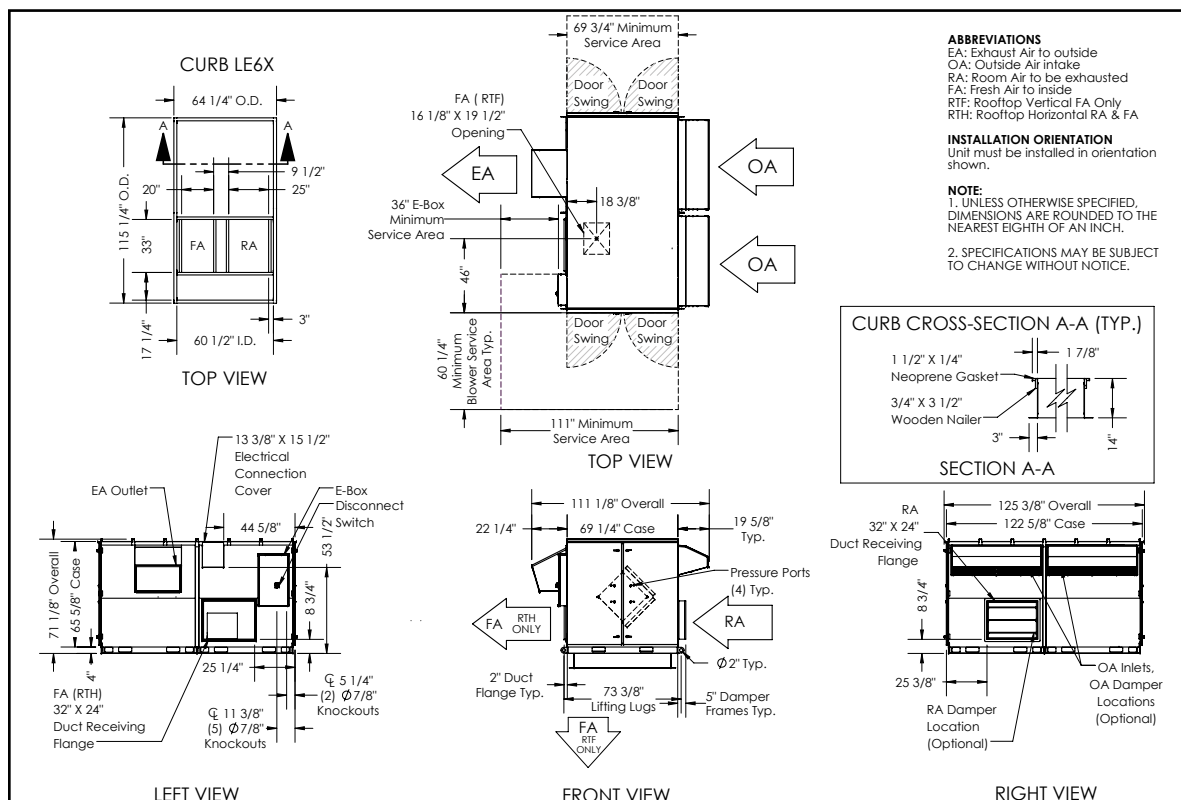

6.5 LE8XRTH-F DIMENSION DRAWING

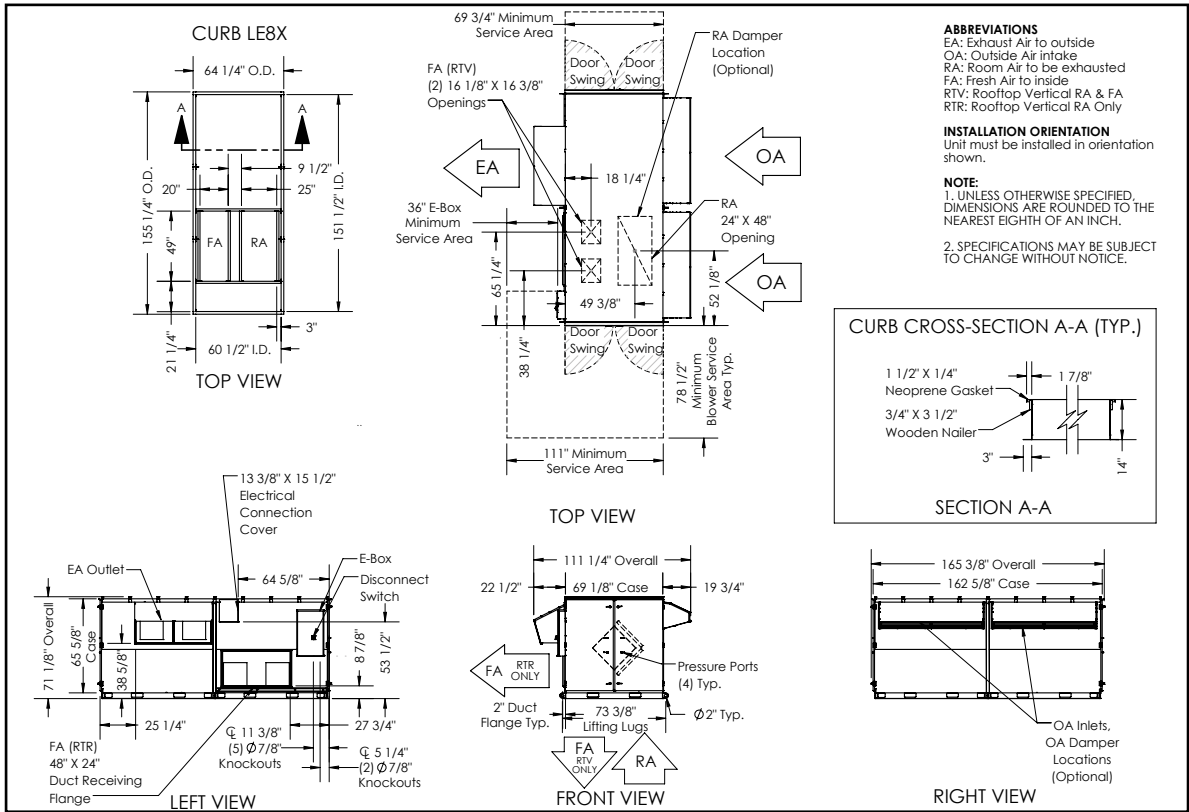

6.6 LE8XRTV-R DIMENSION DRAWING

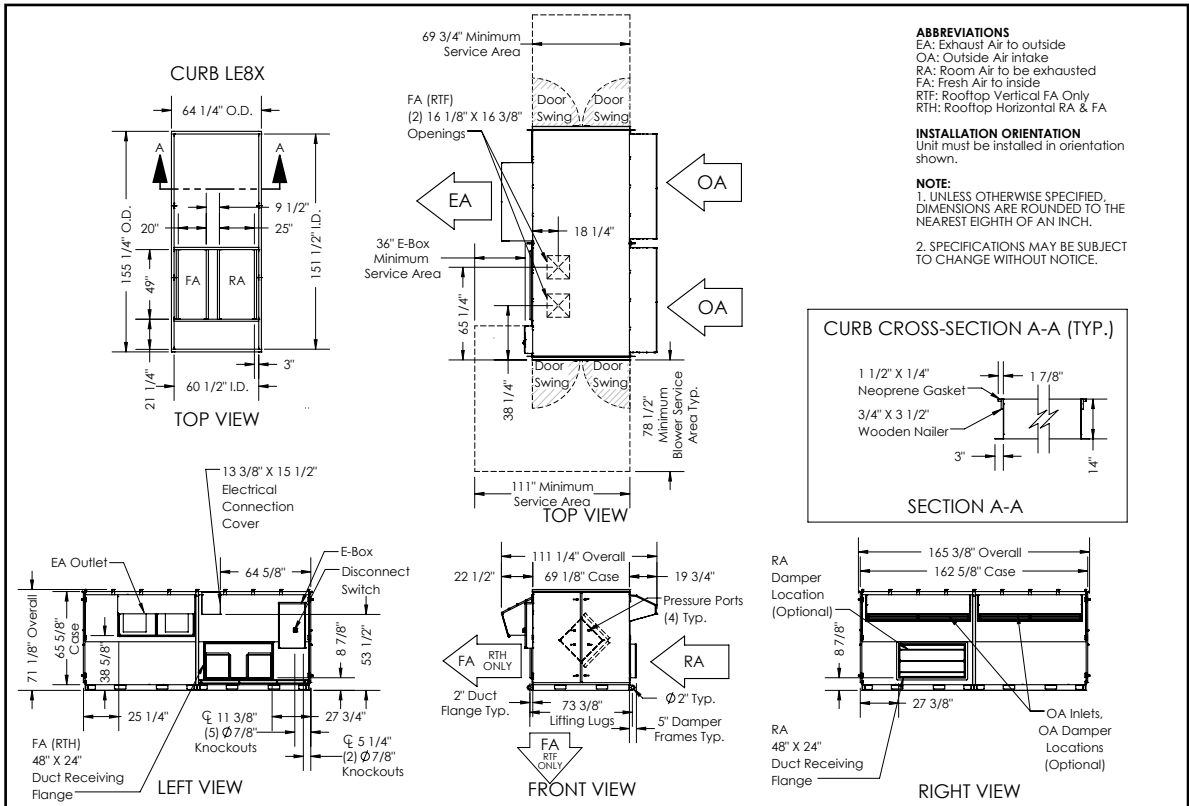

SHIPPING, RIGGING, LIFTING, AND ASSEMBLY: LE MODELS **ERV**

6.7 LE10XRTH-F DIMENSION DRAWING

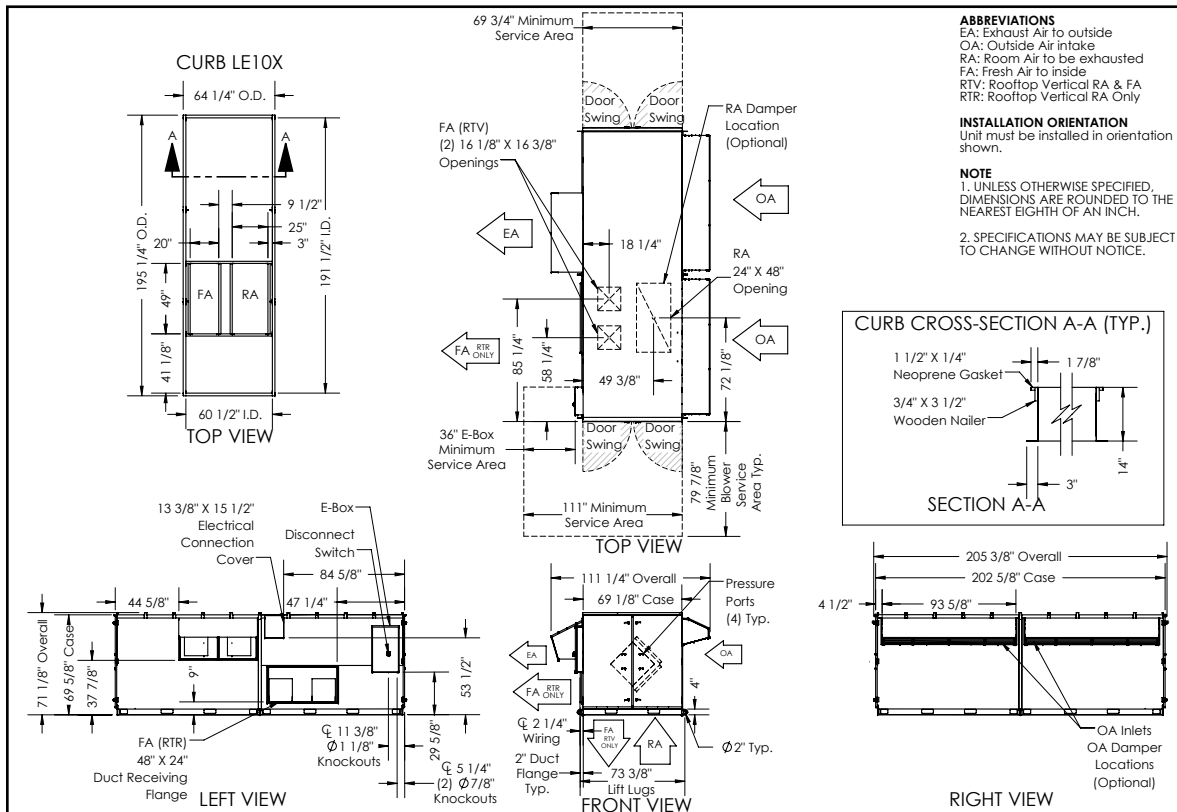

6.8 LE10XRTH-R DIMENSION DRAWING

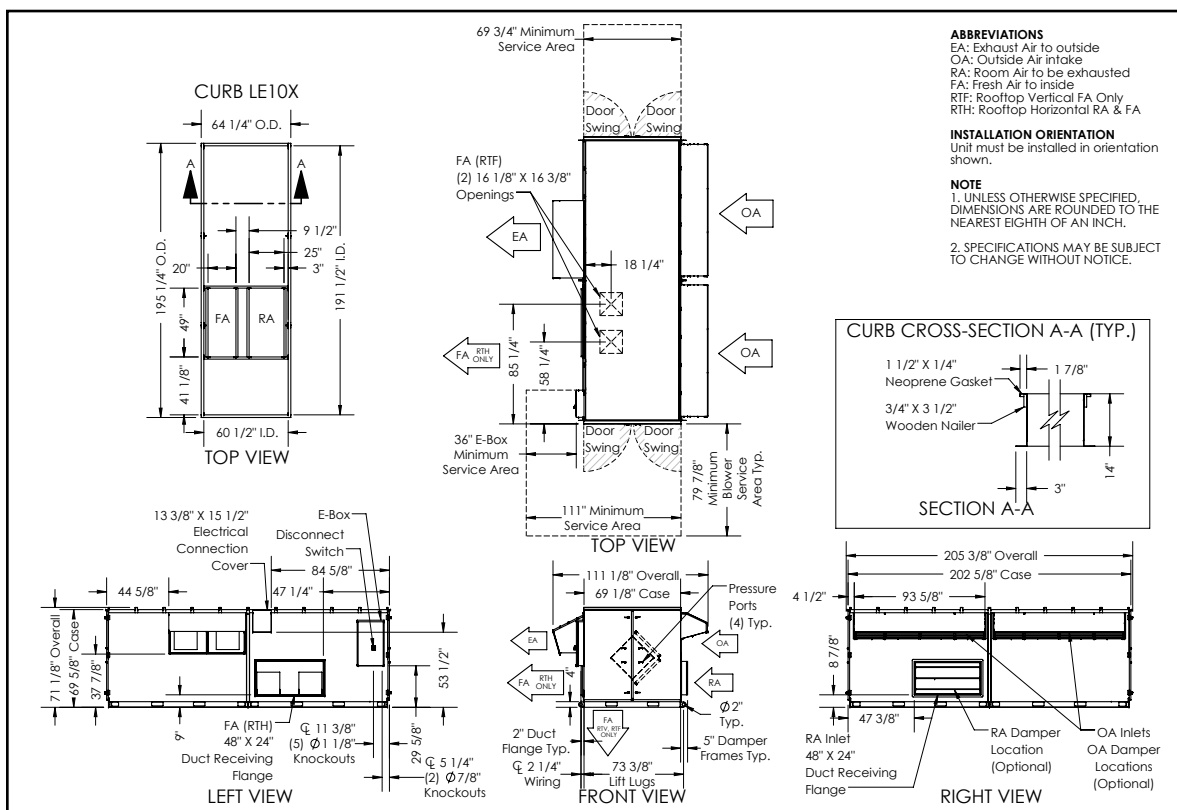

7.0 INDOOR UNIT DIMENSIONS

7.1 LE5XINH DIMENSION DRAWING

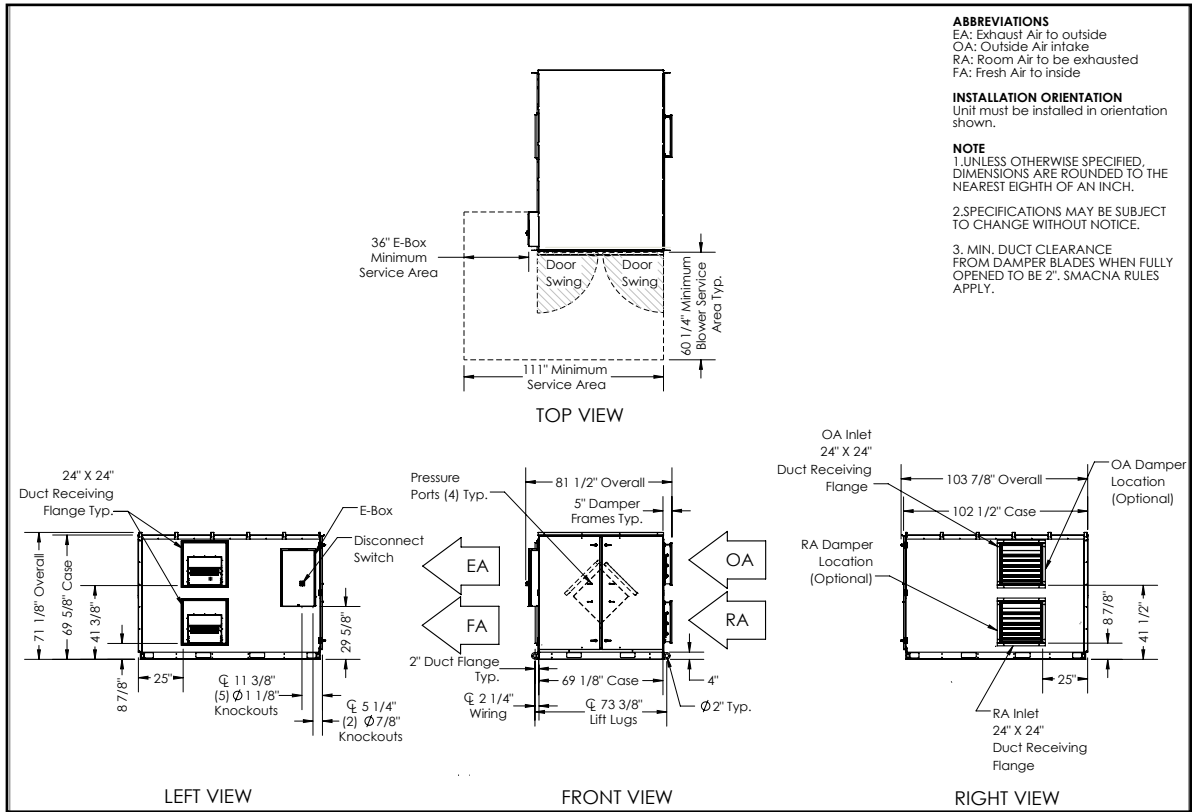

7.2 LE5XINV DIMENSION DRAWING

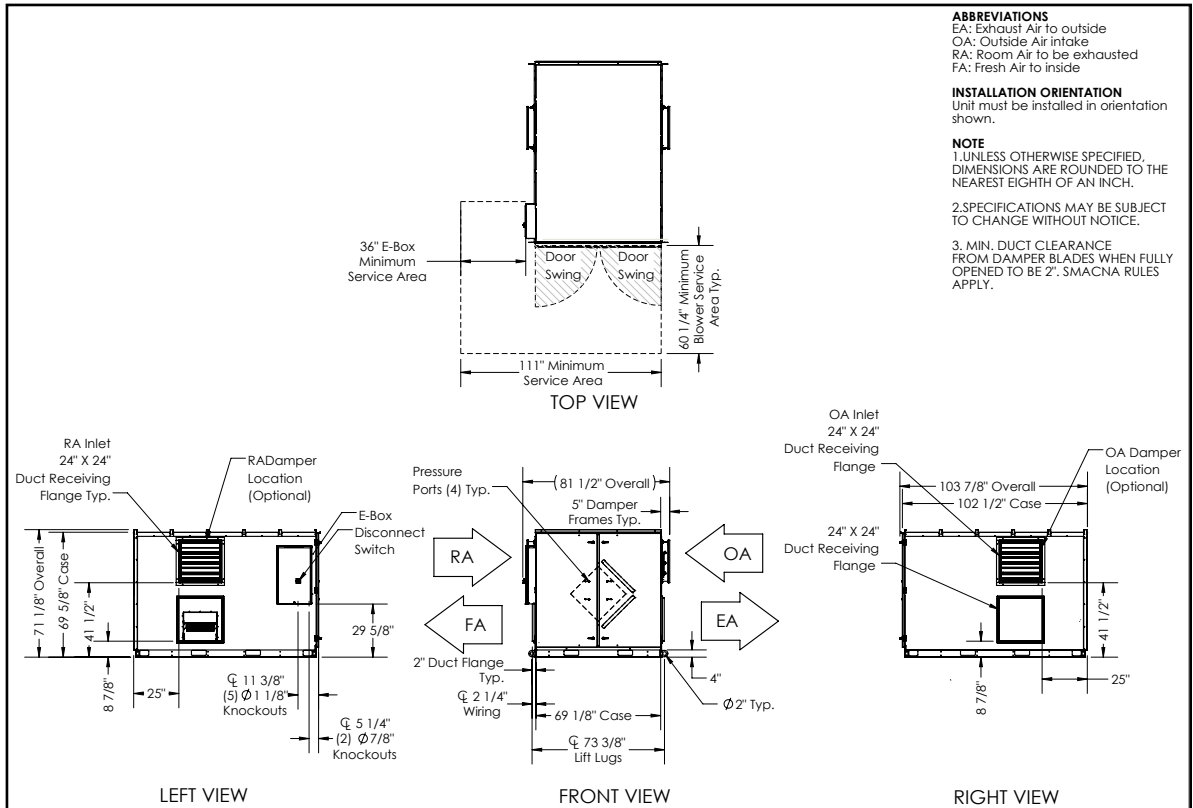

SHIPPING, RIGGING, LIFTING, AND ASSEMBLY: LE MODELS **ERV**

7.3 LE6XINH DIMENSION DRAWING

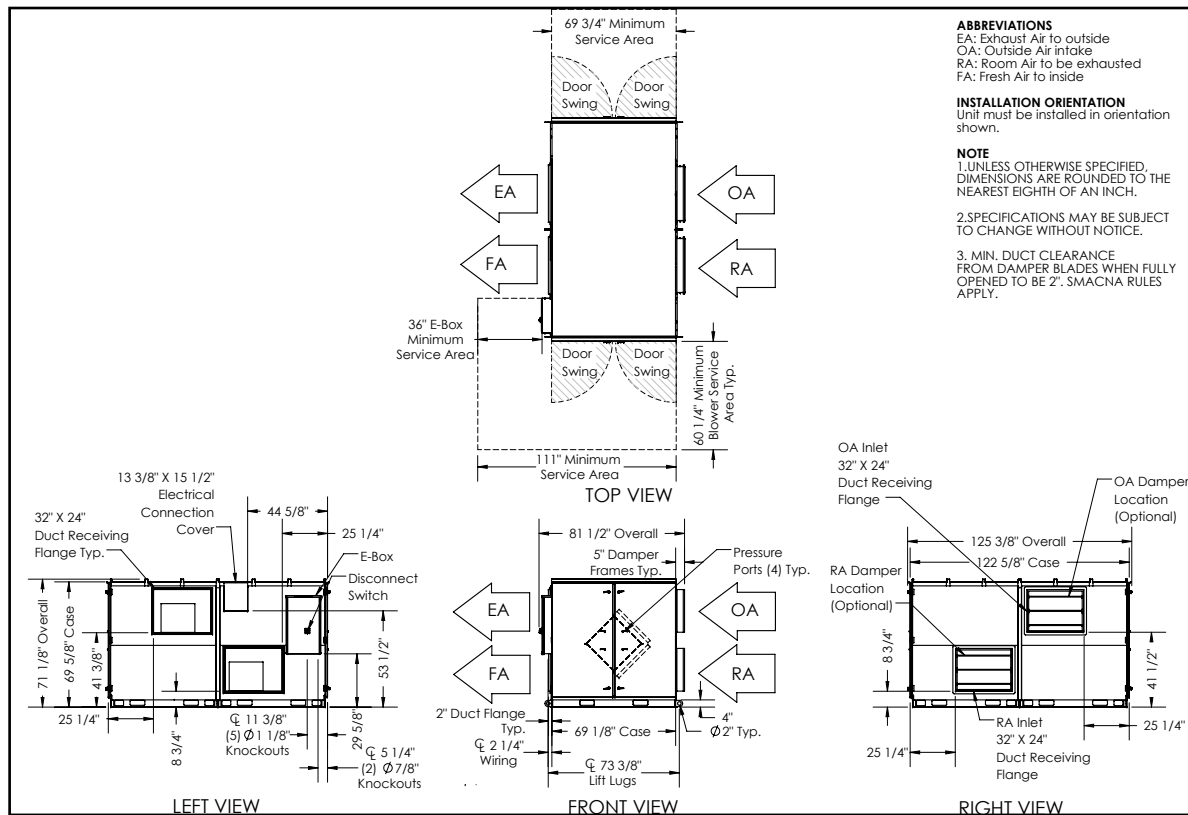

7.4 LE6XINV DIMENSION DRAWING

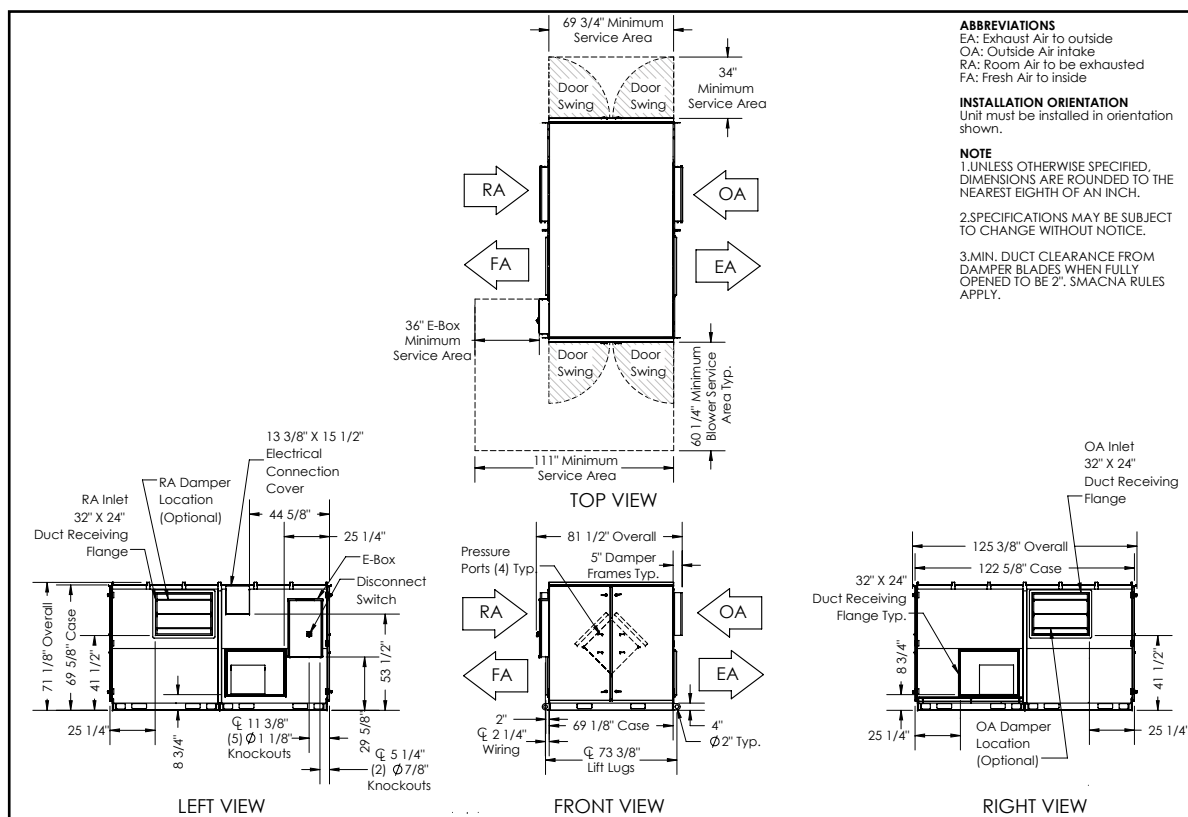

ERV SHIPPING, RIGGING, LIFTING, AND ASSEMBLY: LE MODELS

7.5 LE8XINH DIMENSION DRAWING

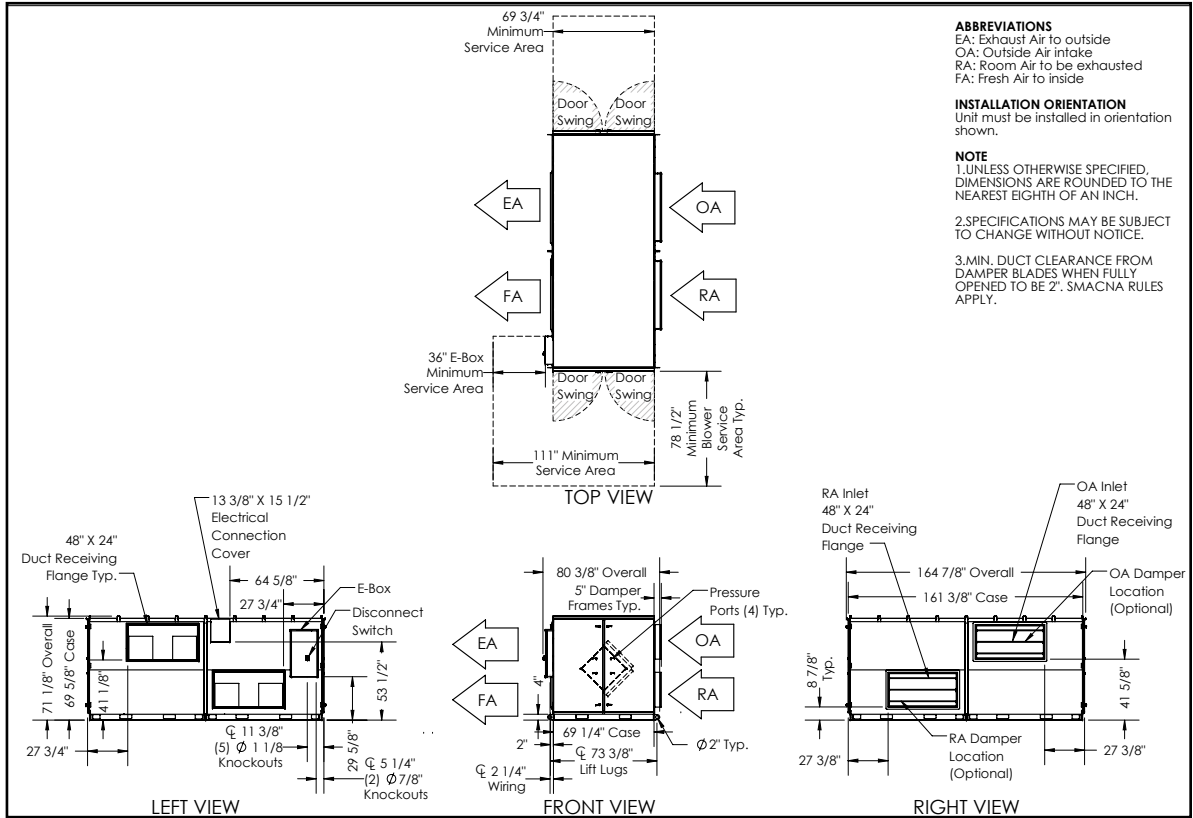

7.6 LE8XINV DIMENSION DRAWING

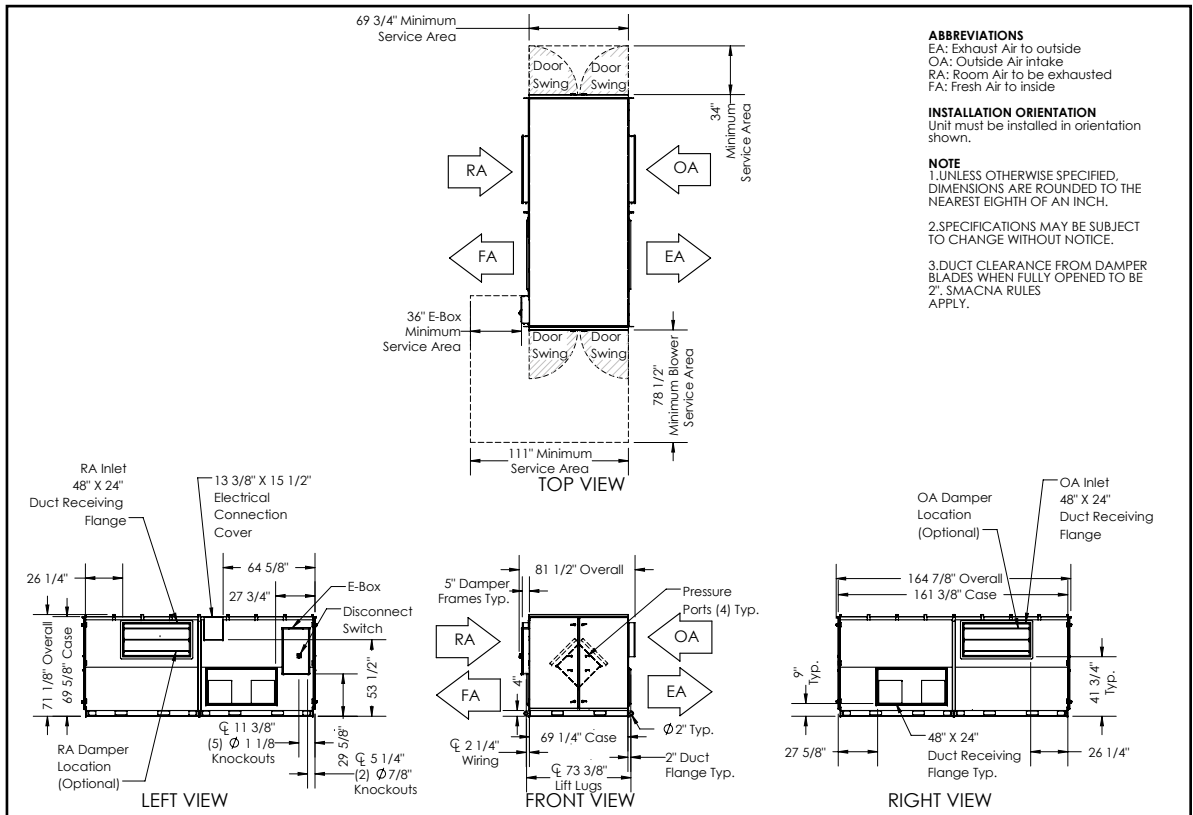

SHIPPING, RIGGING, LIFTING, AND ASSEMBLY: LE MODELS **ERV**

7.7 LE10XINH DIMENSION DRAWING

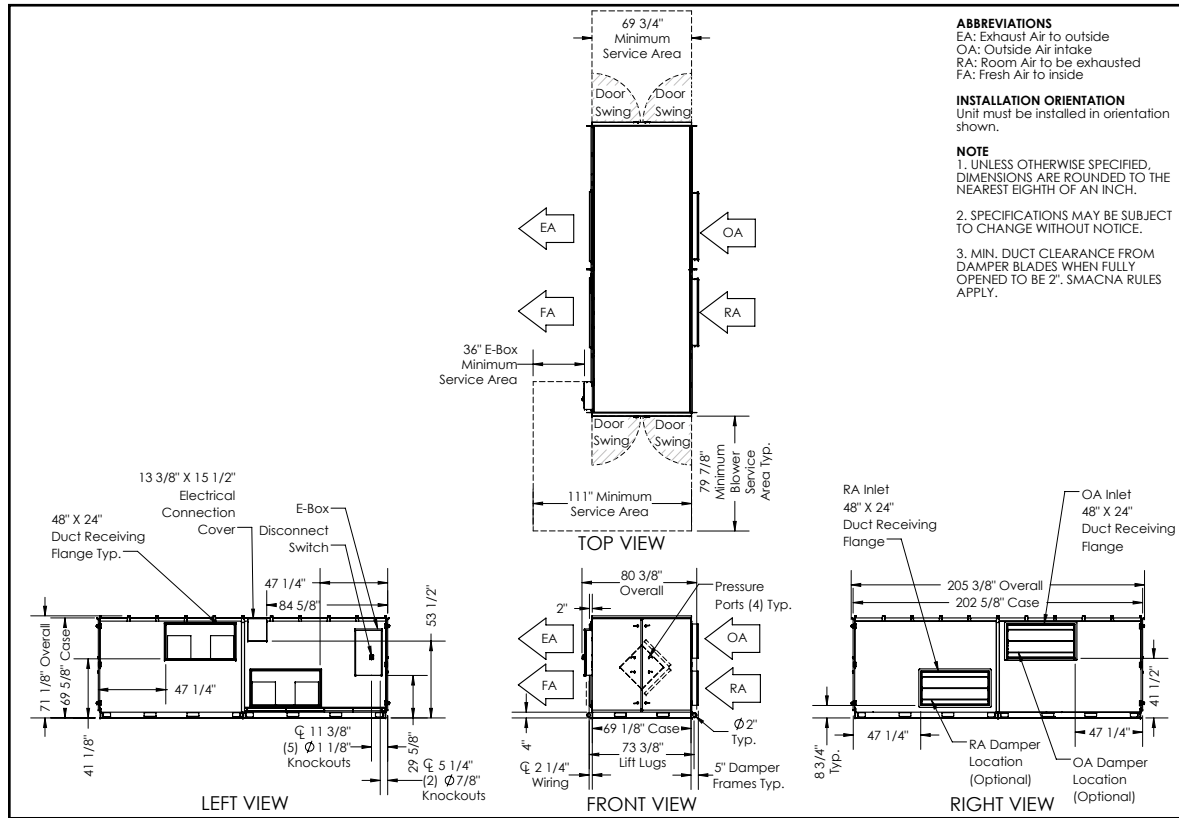

7.8 LE10XINV DIMENSION DRAWING

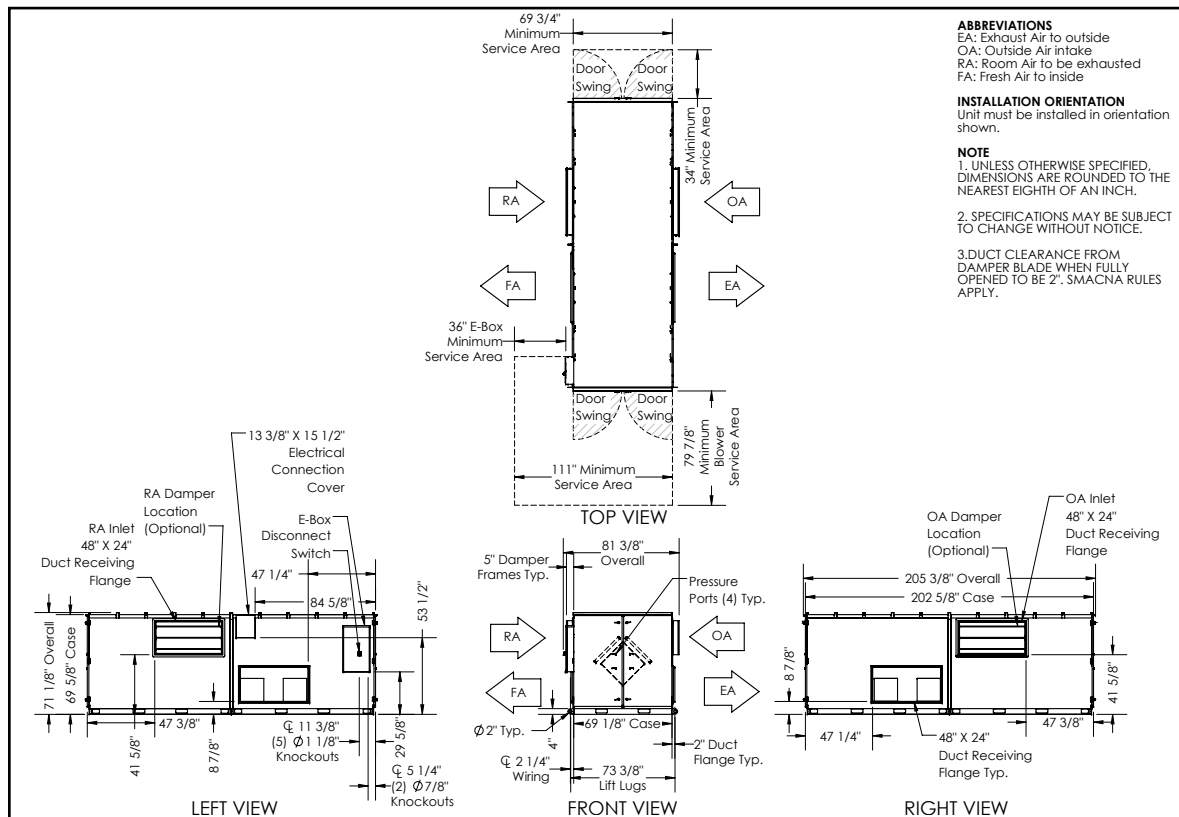

8.0 LE5X CORNER WEIGHTS

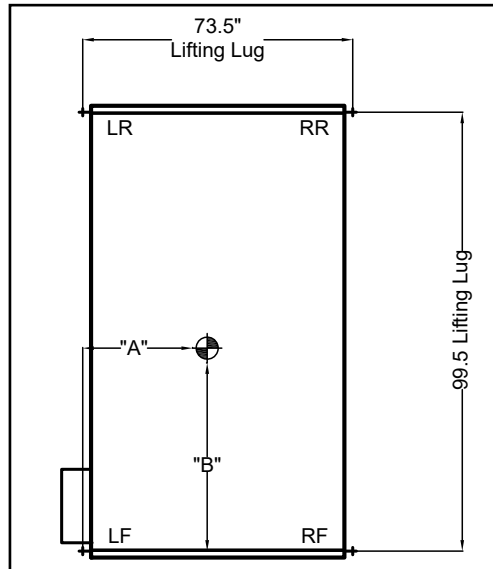

8.1 LE5XRT CORNER WEIGHTS

LE5XRT Lifting Lug Corner Weights (lbs.)					
BASIC UNIT WEIGHTS (lbs.)					
Motors	UNIT	LF	LR	RR	RF
2HP	1782	581	570	304	327
3HP	1828	602	583	309	334
5HP	1880	625	599	314	342
ADDITIONAL WEIGHTS FOR OPTIONS (lbs.)					
Options	UNIT	LF	LR	RR	RF
Double Wall	365	91	91	91	91
VFDs	12	10	1	0	1
RA or EA Damper	33	1	2	19	11
OA or FA Damper	44	1	1	21	21
Total Selected Weights					
Add the additional weights for options to the Basic Unit weights determined by motor size to determine Unit and Corner weights for a specific unit.					
Corner weights shown above include weatherhoods INSIDE THE UNIT, as shipped.					
Center of gravity: A=26" B=49" (+/- 2")					

SHIPPING, RIGGING, LIFTING, AND ASSEMBLY: LE MODELS **ERV****8.2 LE5XINH CORNER WEIGHTS**

LE5XINH Lifting Lug Corner Weights (lbs.)					
BASIC UNIT WEIGHTS (lbs.)					
Motors	UNIT	LF	LR	RR	RF
2HP	1686	566	560	275	285
3HP	1732	587	573	280	292
5HP	1784	610	589	285	300
ADDITIONAL WEIGHTS FOR OPTIONS (lbs.)					
Options	UNIT	LF	LR	RR	RF
Double Wall	365	91	91	91	91
VFDs	12	10	1	0	1
RA or EA Damper	33	1	2	19	11
OA or FA Damper	33	1	2	19	11
Total Selected Weights					
Add the additional weights for options to the Basic Unit weights determined by motor size to determine Unit and Corner weights for a specific unit.					
Center of gravity: A=24" B=49" (+/- 2")					

8.3 LE5XINV CORNER WEIGHTS

LE5XINV Lifting Lug Corner Weights (lbs.)					
BASIC UNIT WEIGHTS (lbs.)					
Motors	UNIT	LF	LR	RR	RF
2HP	1665	444	405	401	415
3HP	1711	456	416	413	426
5HP	1763	470	429	425	439
ADDITIONAL WEIGHTS FOR OPTIONS (lbs.)					
Options	UNIT	LF	LR	RR	RF
Double Wall	365	91	91	91	91
VFDs	12	10	1	0	1
RA or EA Damper	33	11	19	2	1
OA or FA Damper	33	1	2	19	11
Total Selected Weights					
Add the additional weights for options to the Basic Unit weights determined by motor size to determine Unit and Corner weights for a specific unit.					
Center of gravity: A=38" B=49" (+/- 2")					

9.0 LE6X CORNER WEIGHTS

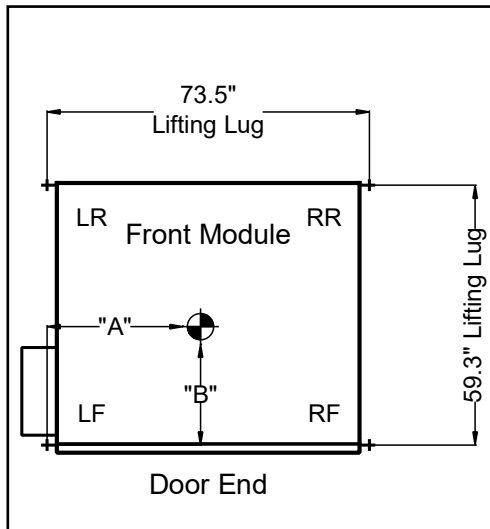
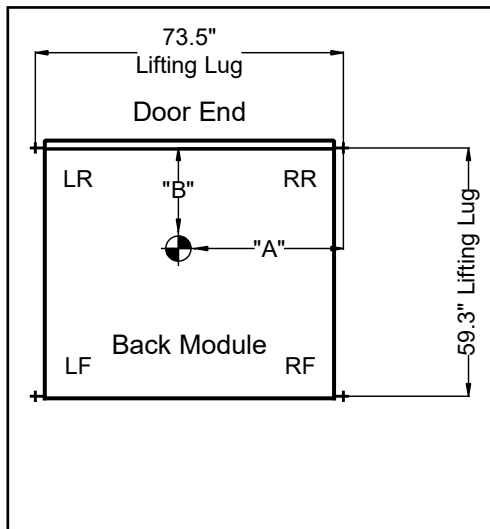
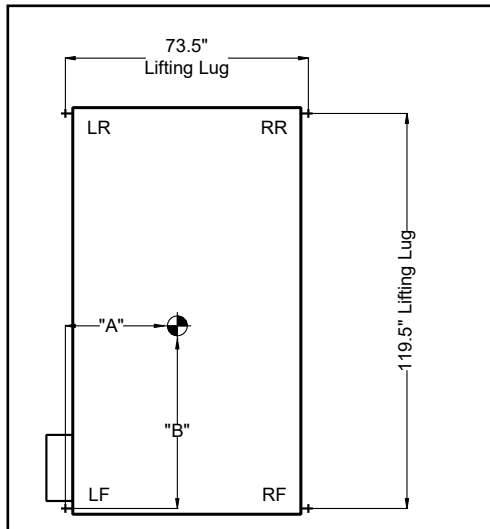

9.1 LE6XRT CORNER WEIGHTS

BASIC UNIT WEIGHTS (lbs.)					
Motors	UNIT	LF	LR	RR	RF
3 HP	2086	579	580	464	463
5 HP	2100	583	585	466	465
7.5 HP	2218	625	630	483	480
ADDITIONAL WEIGHTS FOR OPTIONS (lbs.)					
Options	UNIT	LF	LR	RR	RF
Double Wall	418	105	104	104	105
VFDs	12	10	1	0	1
RA or EA Damper	47	11	1	10	25
OA or FA Damper	58	2	2	27	27
Total Selected Weights					

Add the additional weights for options to the Basic Unit weights determined by motor size to determine Unit and Corner weights for a specific unit.
 Corner weights shown above include weatherhoods INSIDE THE UNIT, as shipped.
 Center of gravity: A=32" B=61" (+/- 2")

BASIC MODULE WEIGHTS (lbs.)					
Motors	UNIT	LF	LR	RR	RF
3 HP	1017	252	190	247	328
5 HP	1024	253	190	249	332
7.5 HP	1083	268	190	260	365
ADDITIONAL WEIGHTS FOR OPTIONS (lbs.)					
Options	UNIT	LF	LR	RR	RF
Double Wall	209	64	40	40	64
VFDs	0	0	0	0	0
RA or EA Damper	0	0	0	0	0
OA or FA Damper	58	2	2	27	27
Total Selected Weights					

Add the additional weights for options to the Basic Module weights determined by motor size to determine Unit and Corner weights for a specific unit.
 Corner weights shown above include weatherhoods INSIDE THE UNIT, as shipped.
 Center of gravity: A=42" B=25" (+/- 2")

BASIC MODULE WEIGHTS (lbs.)					
Motors	UNIT	LF	LR	RR	RF
3 HP	1068	281	243	253	292
5 HP	1076	283	245	254	294
7.5 HP	1135	308	258	259	309
ADDITIONAL WEIGHTS FOR OPTIONS (lbs.)					
Options	UNIT	LF	LR	RR	RF
Double Wall	209	64	40	40	64
VFDs	12	10	1	0	1
RA or EA Damper	47	11	1	10	25
OA or FA Damper	58	2	2	27	27
Total Selected Weights					

Add the additional weights for options to the Basic Unit weights determined by motor size to determine Unit and Corner weights for a specific unit.
 Corner weights shown above include weatherhoods INSIDE THE UNIT, as shipped.
 Center of gravity: A=37" B=27" (+/- 2")

SHIPPING, RIGGING, LIFTING, AND ASSEMBLY: LE MODELS **ERV**

9.2 LE6XINH CORNER WEIGHTS

BASIC UNIT WEIGHTS (lbs.)					
Motors	UNIT	LF	LR	RR	RF
3 HP	1975	565	550	424	436
5 HP	1989	570	555	426	438
7.5 HP	2106	611	600	443	452
ADDITIONAL WEIGHTS FOR OPTIONS (lbs.)					
Options	UNIT	LF	LR	RR	RF
Double Wall	418	105	104	104	105
VFDs	12	10	1	0	1
RA or EA Damper	47	3	1	14	29
OA or FA Damper	47	1	3	29	1
Total Selected Weights					
Add the additional weights for options to the Basic Unit weights determined by motor size to determine Unit and Corner weights for a specific unit. Center of gravity: A=32" B=61" (+/- 2")					

9.3 LE6XINV CORNER WEIGHTS

BASIC UNIT WEIGHTS (lbs.)					
Motors	UNIT	LF	LR	RR	RF
3 HP	1984	569	433	424	558
5 HP	1998	575	434	425	563
7.5 HP	2116	626	442	434	614
ADDITIONAL WEIGHTS FOR OPTIONS (lbs.)					
Motors	UNIT	LF	LR	RR	RF
Double Wall	418	105	104	104	105
VFDs	12	10	1	0	1
RA or EA Damper	47	14	29	3	1
OA or FA Damper	47	1	3	29	14
Total Selected Weights					
Add the additional weights for options to the Basic Unit weights determined by motor size to determine Unit and Corner weights for a specific unit. Center of gravity: A=32" B=57" (+/- 2")					

BASIC MODULE WEIGHTS (lbs.)					
Motors	UNIT	LF	LR	RR	RF
3 HP	943	229	174	233	306
5 HP	950	230	174	235	310
7.5 HP	1009	245	175	246	343
ADDITIONAL WEIGHTS FOR OPTIONS (lbs.)					
Options	UNIT	LF	LR	RR	RF
Double Wall	209	64	40	40	64
VFDs	0	0	0	0	0
RA or EA Damper	0	0	0	0	0
OA or FA Damper	47	1	3	29	14
Total Selected Weights					
Add the additional weights for options to the Basic Module weights determined by motor size to determine Unit and Corner weights for a specific unit. Center of gravity: A=42" B=25" (+/- 2")					

BASIC MODULE WEIGHTS (lbs.)					
Motors	UNIT	LF	LR	RR	RF
3 HP					
5 HP	715	207	158	151	198
7.5 HP					
ADDITIONAL WEIGHTS FOR OPTIONS (lbs.)					
Options	UNIT	LF	LR	RR	RF
Double Wall	209	64	40	40	64
VFDs	0	0	0	0	0
RA or EA Damper	47	14	29	3	1
OA or FA Damper	47	1	3	29	14
Total Selected Weights					
Add the additional weights for options to the Basic Module weights determined by motor size to determine Unit and Corner weights for a specific unit. Center of gravity: A=36" B=23" (+/- 2")					

BASIC MODULE WEIGHTS (lbs.)					
Motors	UNIT	LF	LR	RR	RF
3 HP	1032	307	261	213	250
5 HP	1039	310	263	214	252
7.5 HP	1099	338	277	218	266
ADDITIONAL WEIGHTS FOR OPTIONS (lbs.)					
Options	UNIT	LF	LR	RR	RF
Double Wall	209	64	40	40	64
VFDs	12	10	1	0	1
RA or EA Damper	47	3	1	14	29
OA or FA Damper	0	0	0	0	0
Total Selected Weights					
Add the additional weights for options to the Basic Unit weights determined by motor size to determine Unit and Corner weights for a specific unit. Center of gravity: A=33" B=27" (+/- 2")					

BASIC MODULE WEIGHTS (lbs.)					
Motors	UNIT	LF	LR	RR	RF
3 HP	1269	341	304	294	330
5 HP	1283	345	306	297	335
7.5 HP	1401	387	323	314	376
ADDITIONAL WEIGHTS FOR OPTIONS (lbs.)					
Options	UNIT	LF	LR	RR	RF
Double Wall	209	64	40	40	64
VFDs	12	10	3	0	1
RA or EA Damper	0	0	0	0	0
OA or FA Damper	0	0	0	0	0
Total Selected Weights					
Add the additional weights for options to the Basic Unit weights determined by motor size to determine Unit and Corner weights for a specific unit. Center of gravity: A=36" B=27" (+/- 2")					

10.0 LE8X CORNER WEIGHTS

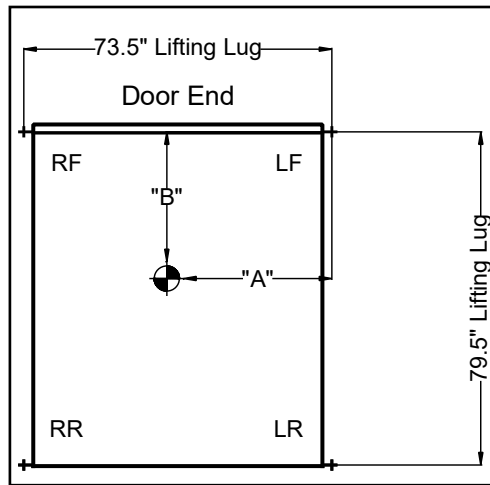
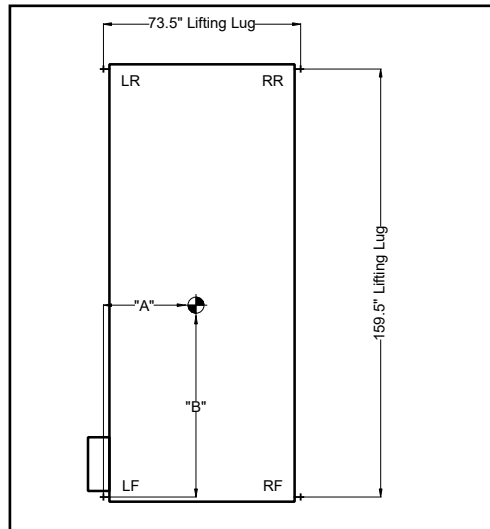

BACK MODULE CORNER WEIGHTS AT LIFTING LUGS

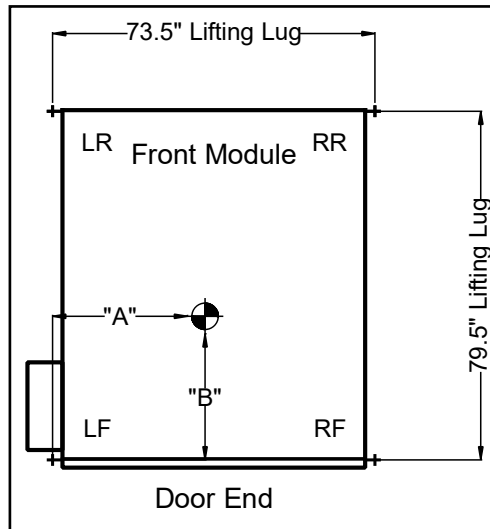

10.1 LE8XRT CORNER WEIGHTS

BASIC UNIT WEIGHTS (lbs.)					
Motors	UNIT	LF	LR	RR	RF
3 HP	2625	753	680	568	624
5 HP	2645	745	737	578	585
7.5 HP	2763	790	780	593	600
ADDITIONAL WEIGHTS FOR OPTIONS (lbs.)					
Options	UNIT	LF	LR	RR	RF
Double Wall	524	131	131	131	131
VFDs	12	10	1	0	1
RA or EA Damper	66	14	1	12	39
OA or FA Damper	88	2	2	42	42
Total Selected Weights					

Add the additional weights for options to the Basic Unit weights determined by motor size to determine Unit and Corner weights for a specific unit.
 Corner weights shown above include weatherhoods INSIDE THE UNIT, as shipped.
 Center of gravity: A=32" B=80" (+/- 2")

BASIC MODULE WEIGHTS (lbs.)					
Motors	UNIT	LF	LR	RR	RF
3 HP	1320	322	244	325	429
5 HP	1327	323	244	327	433
7.5 HP	1386	330	248	347	460
ADDITIONAL WEIGHTS FOR OPTIONS (lbs.)					
Options	UNIT	LF	LR	RR	RF
Double Wall	263	78	54	54	78
VFDs	0	0	0	0	0
RA or EA Damper	0	0	0	0	0
OA or FA Damper	88	2	2	42	42
Total Selected Weights					

Add the additional weights for options to the Basic Module weights determined by motor size to determine Module and Corner weights for a specific unit.
 Corner weights shown above include weatherhoods INSIDE THE UNIT, as shipped.
 Center of gravity: A=33" B=32-3/4" (+/- 2")

BASIC MODULE WEIGHTS (lbs.)					
Motors	UNIT	LF	LR	RR	RF
3 HP	1311	412	301	252	346
5 HP	1318	416	302	252	348
7.5 HP	1377	448	313	253	363
ADDITIONAL WEIGHTS FOR OPTIONS (lbs.)					
Motors	UNIT	LF	LR	RR	RF
Double Wall	263	78	53	53	78
VFDs	12	10	1	0	1
RA or EA Damper	66	14	1	12	39
OA or FA Damper	88	2	2	42	42
Total Selected Weights					

Add the additional weights for options to the Basic Module weights determined by motor size to determine Module and Corner weights for a specific unit.
 Corner weights shown above include weatherhoods INSIDE THE UNIT, as shipped.
 Center of gravity: A=33" B=33" (+/- 2")

SHIPPING, RIGGING, LIFTING, AND ASSEMBLY: LE MODELS **ERV**

10.2 LE8XINH CORNER WEIGHTS

BASIC UNIT WEIGHTS (lbs.)					
Motors	UNIT	LF	LR	RR	RF
3 HP	2480	732	637	517	594
5 HP	2493	724	693	526	550
7.5 HP	2611	769	737	541	564
ADDITIONAL WEIGHTS FOR OPTIONS (lbs.)					
Options	UNIT	LF	LR	RR	RF
Double Wall	524	131	131	131	131
VFDs	12	10	1	0	1
RA or EA Damper	66	3	1	20	42
OA or FA Damper	66	1	3	42	20
Total Selected Weights					

Add the additional weights for options to the Basic Unit weights determined by motor size to determine Unit and Corner weights for a specific unit.
Center of gravity: A=32" B=80" (+/- 2")

10.3 LE8XINV CORNER WEIGHTS

BASIC UNIT WEIGHTS (lbs.)					
Motors	UNIT	LF	LR	RR	RF
3 HP	2495	727	524	521	723
5 HP	2509	733	524	522	730
7.5 HP	2627	787	530	527	783
ADDITIONAL WEIGHTS FOR OPTIONS (lbs.)					
Options	UNIT	LF	LR	RR	RF
Double Wall	524	131	131	131	131
VFDs	12	10	1	0	1
RA or EA Damper	66	20	42	3	1
OA or FA Damper	66	1	3	42	20
Total Selected Weights					

Add the additional weights for options to the Basic Unit weights determined by motor size to determine Unit and Corner weights for a specific unit.
Center of gravity: A=32" B=75" (+/- 2")

BASIC MODULE WEIGHTS (lbs.)					
Motors	UNIT	LF	LR	RR	RF
3 HP	1214	286	229	311	388
5 HP	1221	288	229	312	393
7.5 HP	1280	301	228	324	428
ADDITIONAL WEIGHTS FOR OPTIONS (lbs.)					
Options	UNIT	LF	LR	RR	RF
Double Wall	263	78	54	54	78
VFDs	0	0	0	0	0
RA or EA Damper	0	0	0	0	0
OA or FA Damper	66	1	3	42	20
Total Selected Weights					

Add the additional weights for options to the Basic Module weights determined by motor size to determine Module and Corner weights for a specific unit.
Center of gravity: A=37" B=35" (+/- 2")

BASIC MODULE WEIGHTS (lbs.)					
Motors	UNIT	LF	LR	RR	RF
3 HP	918	255	205	204	254
5 HP					
7.5 HP					
ADDITIONAL WEIGHTS FOR OPTIONS (lbs.)					
Options	UNIT	LF	LR	RR	RF
Double Wall	263	77	54	54	77
VFDs	0	0	0	0	0
RA or EA Damper	66	20	42	3	1
OA or FA Damper	66	1	3	42	20
Total Selected Weights					

Add the additional weights for options to the Basic Module weights determined by motor size to determine Module and Corner weights for a specific unit.
Center of gravity: A=36-3/4" B=35" (+/- 2")

BASIC MODULE WEIGHTS (lbs.)					
Motors	UNIT	LF	LR	RR	RF
3 HP	1265	409	295	235	326
5 HP	1272	413	296	235	328
7.5 HP	1331	445	307	236	343
ADDITIONAL WEIGHTS FOR OPTIONS (lbs.)					
Options	UNIT	LF	LR	RR	RF
Double Wall	263	78	54	54	78
VFDs	12	10	1	0	1
RA or EA Damper	66	3	1	20	42
OA or FA Damper	0	0	0	0	0
Total Selected Weights					

Add the additional weights for options to the Basic Module weights determined by motor size to determine Module and Corner weights for a specific unit.
Center of gravity: A=33" B=33" (+/- 2")

BASIC MODULE WEIGHTS (lbs.)					
Motors	UNIT	LF	LR	RR	RF
3 HP	1577	461	329	328	459
5 HP	1591	468	329	328	466
7.5 HP	1709	515	341	339	513
ADDITIONAL WEIGHTS FOR OPTIONS (lbs.)					
Options	UNIT	LF	LR	RR	RF
Double Wall	263	78	53	53	78
VFDs	12	10	1	0	1
RA or EA Damper	0	0	0	0	0
OA or FA Damper	0	0	0	0	0
Total Selected Weights					

Add the additional weights for options to the Basic Module weights determined by motor size to determine Module and Corner weights for a specific unit.
Center of gravity: A=36" B=33" (+/- 2")

11.0 LE10X CORNER WEIGHTS

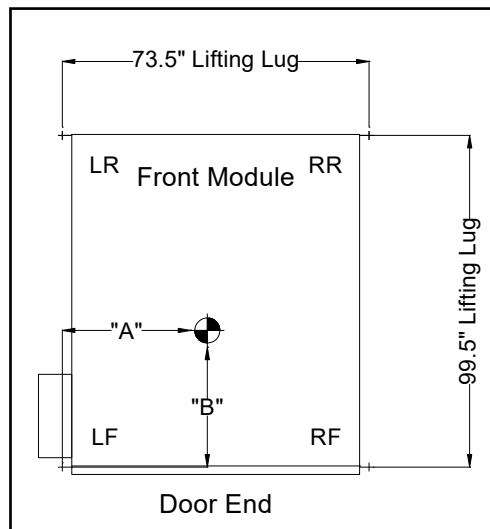
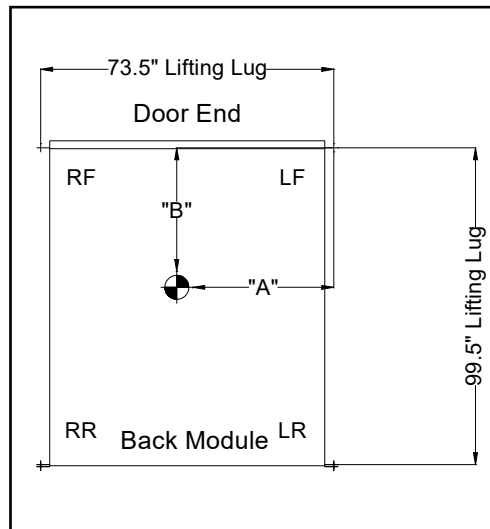
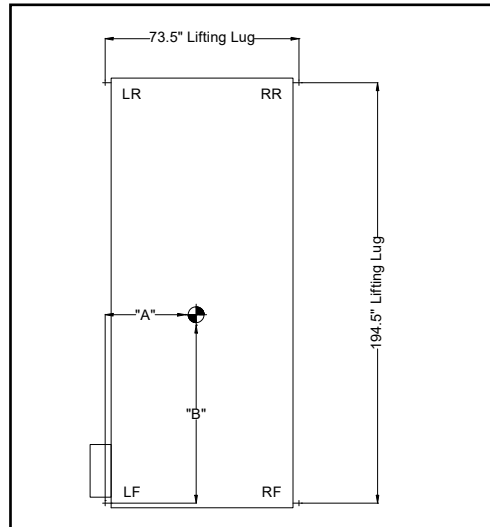

11.1 LE10XRT CORNER WEIGHTS

BASIC UNIT WEIGHTS (lbs.)					
Motors	UNIT	LF	LR	RR	RF
3 HP	3031	842	841	674	674
5 HP	3045	847	846	676	676
7.5 HP	3163	892	890	690	691
10 HP	3201	906	904	695	696
ADDITIONAL WEIGHTS FOR OPTIONS (lbs.)					
Options	UNIT	LF	LR	RR	RF
Double Wall	626	155	158	158	155
VFDs	12	10	1	0	1
RA or EA Damper	66	14	1	12	39
OA or FA Damper	88	2	2	42	42
Total Selected Weights					

Add the additional weights for options to the Basic Unit weights determined by motor size to determine Unit and Corner weights for a specific unit.
Center of gravity: A=32" B= 101" (+/- 2")

BASIC MODULE WEIGHTS (lbs.)					
Motors	UNIT	LF	LR	RR	RF
3 HP	1539	330	334	440	435
5 HP	1546	354	346	419	427
7.5 HP	1605	363	348	437	456
10 HP	1624	367	349	443	466
ADDITIONAL WEIGHTS FOR OPTIONS (lbs.)					
Options	UNIT	LF	LR	RR	RF
Double Wall	313	91	66	66	91
VFDs	0	0	0	0	0
RA or EA Damper	0	0	0	0	0
OA or FA Damper	88	2	2	42	42
Total Selected Weights					

Add the additional weights for options to the Basic Module weights determined by motor size to determine Unit and Corner weights for a specific unit.
Center of gravity: A=41" B= 48" (+/- 2")

BASIC UNIT WEIGHTS (lbs.)					
Motors	UNIT	LF	LR	RR	RF
3 HP	1493	445	396	307	344
5 HP	1500	448	398	308	346
7.5 HP	1559	474	415	313	357
10 HP	1578	483	420	314	361
ADDITIONAL WEIGHTS FOR OPTIONS (lbs.)					
Options	UNIT	LF	LR	RR	RF
Double Wall	313	77	79	79	77
VFDs	12	10	1	0	1
RA or EA Damper	66	14	1	12	39
OA or FA Damper	88	2	2	42	42
Total Selected Weights					

Add the additional weights for options to the Basic Unit weights determined by motor size to determine Unit and Corner weights for a specific unit.
Center of gravity: A=31" B= 46" (+/- 2")

SHIPPING, RIGGING, LIFTING, AND ASSEMBLY: LE MODELS **ERV**

11.2 LE10XINH CORNER WEIGHTS

BASIC UNIT WEIGHTS (lbs.)					
Motors	UNIT	LF	LR	RR	RF
3 HP	2859	837	827	594	601
5 HP	2872	842	832	595	603
7.5 HP	2991	888	877	609	617
10 HP	3028	902	891	614	621
ADDITIONAL WEIGHTS FOR OPTIONS (lbs.)					
Options	UNIT	LF	LR	RR	RF
Double Wall	627	156	159	158	154
VFDs	12	10	1	0	1
RA or EA Damper	66	3	1	20	42
OA or FA Damper	66	1	3	0	1
Total Selected Weights					

Add the additional weights for options to the Basic Unit weights determined by motor size to determine Unit and Corner weights for a specific unit.
Center of gravity: A=32" B= 101" (+/- 2")

11.3 LE10XINV CORNER WEIGHTS

BASIC UNIT WEIGHTS (lbs.)					
Motors	UNIT	LF	LR	RR	RF
3 HP	2859	819	665	616	759
5 HP	2873	825	666	617	765
7.5 HP	2990	874	676	628	812
10 HP	3028	889	679	632	828
ADDITIONAL WEIGHTS FOR OPTIONS (lbs.)					
Options	UNIT	LF	LR	RR	RF
Double Wall	616	153	155	155	153
VFDs	12	10	1	0	1
RA or EA Damper	66	20	42	3	1
OA or FA Damper	66	1	3	42	20
Total Selected Weights					

Add the additional weights for options to the Basic Unit weights determined by motor size to determine Unit and Corner weights for a specific unit.
Center of gravity: A=32" B= 96" (+/- 2")

BASIC MODULE WEIGHTS (lbs.)					
Motors	UNIT	LF	LR	RR	RF
3 HP	1423	340	267	359	456
5 HP	1430	341	268	361	460
7.5 HP	1489	350	271	378	490
10 HP	1508	353	271	384	499
ADDITIONAL WEIGHTS FOR OPTIONS (lbs.)					
Options	UNIT	LF	LR	RR	RF
Double Wall	313	91	66	66	91
VFDs	0	0	0	0	0
RA or EA Damper	0	0	0	0	0
OA or FA Damper	66	1	3	42	20
Total Selected Weights					

Add the additional weights for options to the Basic Module weights determined by motor size to determine Unit and Corner weights for a specific unit.
Center of gravity: A=43" B=43" (+/- 2")

BASIC MODULE WEIGHTS (lbs.)					
Motors	UNIT	LF	LR	RR	RF
3 HP	1127	349	204	212	362
5 HP	1127	349	204	212	362
7.5 HP	1127	349	204	212	362
10 HP	1127	349	204	212	362
ADDITIONAL WEIGHTS FOR OPTIONS (lbs.)					
Options	UNIT	LF	LR	RR	RF
Double Wall	313	91	66	66	91
VFDs	0	0	0	0	0
RA or EA Damper	66	20	42	3	1
OA or FA Damper	66	1	3	42	20
Total Selected Weights					

Add the additional weights for options to the Basic Module weights determined by motor size to determine Unit and Corner weights for a specific unit.
Center of gravity: A=37" B= 37" (+/- 2")

BASIC UNIT WEIGHTS (lbs.)					
Motors	UNIT	LF	LR	RR	RF
3 HP	1436	384	389	286	322
5 HP	1443	441	391	287	323
7.5 HP	1502	467	408	292	334
10 HP	1521	477	412	293	339
ADDITIONAL WEIGHTS FOR OPTIONS (lbs.)					
Options	UNIT	LF	LR	RR	RF
Double Wall	313	78	79	79	78
VFDs	12	10	1	0	1
RA or EA Damper	66	14	1	12	39
OA or FA Damper	0	0	0	0	0
Total Selected Weights					

Add the additional weights for options to the Basic Unit weights determined by motor size to determine Unit and Corner weights for a specific unit.
Center of gravity: A=30" B= 46" (+/- 2")

BASIC UNIT WEIGHTS (lbs.)					
Motors	UNIT	LF	LR	RR	RF
3 HP	1732	468	442	399	423
5 HP	1746	473	443	401	428
7.5 HP	1864	511	464	423	466
10 HP	1902	525	469	428	479
ADDITIONAL WEIGHTS FOR OPTIONS (lbs.)					
Options	UNIT	LF	LR	RR	RF
Double Wall	308	76	78	78	76
VFDs	12	10	1	0	1
RA or EA Damper	0	0	0	0	0
OA or FA Damper	0	0	0	0	0
Total Selected Weights					

Add the additional weights for options to the Basic Unit weights determined by motor size to determine Unit and Corner weights for a specific unit.
Center of gravity: A=35" B= 47" (+/- 2")



About RenewAire

For over 40 years, **RenewAire** has been a pioneer in enhancing indoor air quality (IAQ) in commercial and residential buildings of every size. This is achieved while maximizing sustainability through our fifth-generation, static-plate, enthalpic-core **Energy Recovery Ventilators (ERVs)** that optimize energy efficiency, lower capital costs via load reduction and decrease operational expenses by minimizing equipment needs, resulting in significant energy savings. Our ERVs are competitively priced, simple to install, easy to use and maintain and have a quick payback. They also enjoy the industry's best warranty with the lowest claims due to long-term reliability derived from innovative design practices, expert workmanship and **Quick Response Manufacturing (QRM)**.

As the pioneer of static-plate core technology in North America, RenewAire is the largest ERV producer in the USA. We're **committed to sustainable manufacturing** and lessening our environmental footprint, and to that end our Waunakee, WI plant is 100% powered by wind turbines. The facility is also one of the few buildings worldwide to be LEED and Green Globes certified, as well as having achieved ENERGY STAR Building status. In 2010, RenewAire joined the Soler & Palau (S&P) Ventilation Group in order to provide direct access to the latest in energy-efficient air-moving technologies. For more information, visit: renewaire.com

201 Raemisch Road | Waunakee, WI | 53597 | 800.627.4499 | RenewAire.com