

# PREMIUM COMMERCIAL CONTROLS

## Installation, Operation and Maintenance Manual

For HE-Series, LE-Series, and DN-Series Units

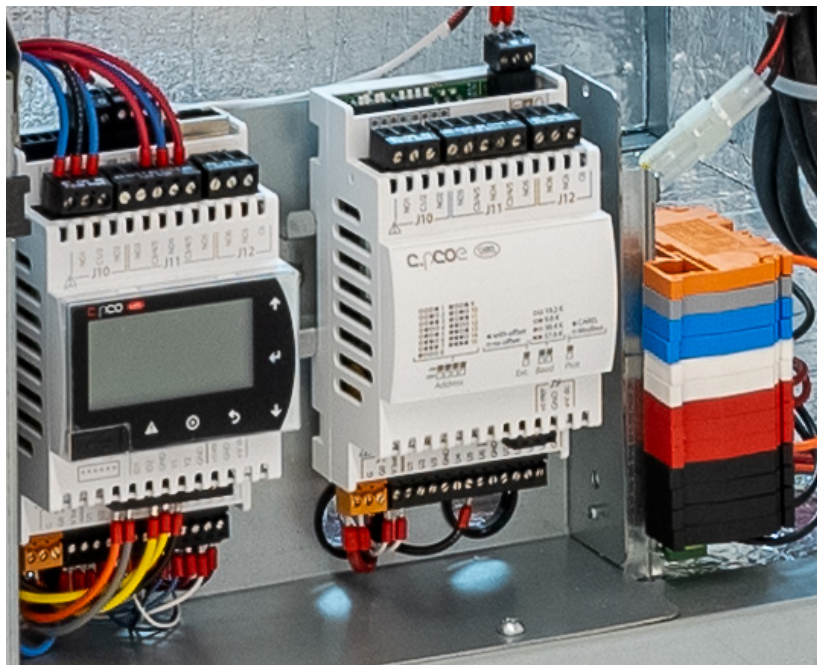

Carel c.pCO Mini

Carel c.pCOe Expansion Board

Colored DIN Terminals

This manual applies to energy recovery ventilator (ERV) units with Premium controls version 4.xx.xx. For previous versions refer to the older manual. The version number can be seen on the splash screen when the unit power is cycled.



Newer units also have this version information in the *Unit Status* screens.

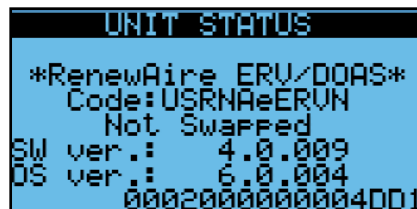

**⚠ WARNING**

**ARC FLASH AND ELECTRIC SHOCK HAZARD**

Microprocessor controllers as discussed in this manual are typically installed in a control panel where high voltages are present. Whenever accessing any controller, disconnect all electric power supplies, verify with a voltmeter that electric power is OFF and wear protective equipment per NFPA 70E when working within the electric enclosure. Failure to comply can cause serious injury or death.

The line side of the disconnect switch contains live high-voltage.

The only way to ensure that there is NO voltage inside the unit is to install and open a remote disconnect switch and verify that power is off with a voltmeter. Refer to unit electrical schematic.

Follow all local codes.

**⚠ CAUTION**

**RISK OF ELECTRIC SHOCK OR EQUIPMENT DAMAGE**

Whenever electrical wiring is connected, disconnected or changed, the power supply to the ERV and its controls must be disconnected. Lock and tag the disconnect switch or circuit breaker to prevent accidental reconnection of electric power.

**⚠ CAUTION**

**RISK OF COMPUTER SECURITY BREACH**

This controller is capable of being connected to a network. Any device that is connected to a network is susceptible to unauthorized access and hostile activities. It is the owner's responsibility to determine acceptable risks and to safeguard the security of the controller and all connected devices.

**IMPORTANT**

This controller is only for use in protected environments. It is not to be exposed to the weather or exposed to extremes in temperature.

**IMPORTANT**

Risk of degraded unit efficiency. Improper adjustment of unit setpoints may result in the ERV operating inefficiently. Improper selection of Input Offsets may cause incorrect or inefficient operation of the ERV.

**IMPORTANT**

Only persons who have been properly trained and authorized are to access the ERV control panel and the controller. Changes to the controller settings are to be made only by trained and authorized personnel. All changes to the controller settings are to be documented in the Controller Maintenance Records section in this manual.

**IMPORTANT**

This control system is subject to periodic updates in firmware and the User Manual itself. Please contact RenewAire Support at [RenewAireSupport@RenewAire.com](mailto:RenewAireSupport@RenewAire.com) to determine if you have the most recent manual and firmware.





<b>1.0 OVERVIEW</b>	<b>10</b>	<b>5.2 OPTIONS FOR SUPPLY FAN CONTROL</b>	<b>32</b>
1.1 CONTROL SEQUENCE OVERVIEW	10	5.2.1 Constant Fan Speed Option	32
1.2 ENERGY RECOVERY BASICS	11	5.2.2 SA Flow Control Option	33
1.3 TEMPERATURE SENSORS	11	5.2.3 Supply Duct Static Pressure Control Option	33
1.4 COMBINATION TEMPERATURE AND HUMIDITY TRANSDUCERS	12	5.2.4 Room Static Pressure Control Option	34
1.5 CURRENT SENSORS	12	5.2.5 CO <sub>2</sub> /VOC Control Option	35
1.6 FILTER MONITORING	13	5.2.6 CO <sub>2</sub> Flow Control Option	35
1.7 AIRFLOW MONITORING	13	5.2.7 Exhaust Fan Command Tracking Control Option	36
1.7 SENSOR LOCATIONS	14	5.2.8 Exhaust Fan Flow Tracking Control Option	37
<b>2.0 CONTROLLER OVERVIEW</b>	<b>15</b>	<b>5.3 OPTIONS FOR EXHAUST FAN CONTROL</b>	<b>37</b>
2.1 CONTROLLER ACCESS METHODS	17	5.3.1 Constant Fan Speed Option	37
2.1.1 Using the Remote User Terminal (RUT)	17	5.3.2 EA Flow Control Option	38
2.1.2 Connecting Using Internal Web Pages	18	5.3.3 Supply Fan Command Tracking Control Option	39
2.1.3 Setting the PC IP Address	19	5.3.4 Supply Fan Flow Tracking Control Option	39
2.1.4 Using the Multikey Function of the Web Pages	20	5.3.5 Room Static Pressure Control Option	39
2.2 CONTROLLER MENU STRUCTURE	20	5.3.6 Exhaust Duct Static Pressure Control Option	40
2.2.1 User Menu Structure	20		
2.2.2 Password Protected Menu Structure	21		
2.2.3 Password Entry	21		
<b>3.0 GENERAL FLOW FOR SETUP AND RUNNING UNIT</b>	<b>21</b>	<b>6.0 TEMPERING CONTROL</b>	<b>41</b>
<b>4.0 UNIT CONFIGURATION</b>	<b>22</b>	6.1 MODES OF OPERATION	41
4.1 CONFIGURE GENERAL SETTING	22	6.2 DEHUMIDIFICATION	42
4.1.1 Setting the Time and Date	22	6.2.1 Dehumidification Mode Settings	42
4.1.2 Setting the Unit of Measure	22	6.2.2 Dehumidification Types and Settings	43
4.1.3 Setting the IP Address of the Controller	22	6.2.2.1 Dehumidification with Hot Gas Reheat	43
4.1.4 Scheduler	23	6.2.2.2 Dehumidification with Reheat from Heat Source	44
4.2 VERIFY UNIT CONFIGURATION	23	6.2.2.3 Dehumidification with No Reheat	45
4.2.1 Main Unit Configuration	23	6.2.2.4 Dehumidification Disabled	45
4.2.2 I/O Configuration	25	<b>6.3 HEATING</b>	<b>45</b>
4.2.2.1 Digital Inputs	25	6.3.1 Heating Mode	46
4.2.2.2 Analog Inputs	25	6.3.2 Setpoint Type and Control Type	46
4.2.2.3 Field-Installed Sensors and General Wiring	26	6.3.3 Heating Types	46
4.2.3 CO <sub>2</sub> /VOC Sensors	27	6.3.3.1 0–10VDC Gas or Electric Heating	47
4.2.4 Differential Pressure Duct or Room Pressure Sensor	28	6.3.3.2 10–0VDC Hot Water Valve	48
4.2.5 CA Temperature Sensor	29	6.3.3.3 Single Stage Heater	49
<b>5.0 UNIT OPERATION AND FAN CONTROL</b>	<b>30</b>	6.3.3.4 Two-Stage Heater	50
5.1 SEQUENCE OF OPERATION FOR UNIT START	30	<b>6.4 COOLING</b>	<b>52</b>
5.1.1 Digital Input (ID1) Unit On/Off	31	6.4.1 Cooling Mode	52
5.1.1.1 Optional Smoke Detector	31	6.4.2 SetP	52
5.1.1.2 Optional Motion Sensor	32	6.4.3 Cooling Control Type	52
5.1.2 Isolation Dampers	32	6.4.4 Cooling Types	52
5.1.3 Fans	32	6.4.4.1 On/Off: One Stage of Cooling	53
		6.4.4.2 2-Stage: Two Stages of Cooling	54
		6.4.4.3 CW Mod: Chilled Water Modulating Coil	56
		6.4.4.4 Cooling with Modulating Bypass	57
		<b>6.5 COMBINED TEMPERING</b>	<b>57</b>
		6.5.1 Heat Pump 1-Stage: with or without 0–10VDC Aux Heat	57
		6.5.1.1 Heat Pump 1-Stage Mode	57
		6.5.1.2 Heat Pump 1-Stage Cooling Operation	57
		6.5.1.3 Heat Pump 1 Stage Heating Operation	58
		6.5.1.4 Heat Pump 1-Stage Auxiliary Heat	59
		6.5.1.5 Heat Pump 1-Stage Reversing Valve	59
		6.5.1.6 Heat Pump 1 Stage System Monitoring	59
		6.5.2 Heat Pump 2-Stage: with or without 0–10VDC Aux Heat	60
		6.5.2.1 Heat Pump 2-Stage Mode	60
		6.5.2.2 Heat Pump 2-Stage Cooling Operation	60

6.5.2.3 Heat Pump 2-Stage Heating Operation .....	61	<b>8.2 CALIBRATING I/O .....</b>	<b>82</b>
6.5.2.4 Heat Pump 2-Stage Auxiliary Heat.....	62	<b>8.3 GENERAL UNIT CONTROL WIRING .....</b>	<b>82</b>
6.5.2.5 Heat Pump 2-Stage Reversing Valve.....	62	8.3.1 Sensor Inputs .....	82
6.5.2.6 Heat Pump 2-Stage System Monitoring .....	63	8.3.2 Digital Inputs.....	84
6.5.3 VRF.....	64	8.3.3 Digital Outputs .....	85
6.5.3.1 VRF Mode.....	64	8.3.4 Analog Outputs.....	86
6.5.3.2 VRF Cooling Operation .....	64	8.3.4.1 Wiring to Three-Wire Valves .....	86
6.5.3.3 VRF Heating Operation.....	64	8.3.5 Sample Power Wiring Schematic.....	87
6.5.3.4 VRF Monitoring.....	65	8.3.6 Sample Control Wiring Schematic .....	88
6.5.4 Dual Temperature Coil .....	65	8.3.6 Sample Field Wiring Schematic .....	89
6.5.4.1 Dual Temperature Coil Mode .....	66	<b>9.0 ALARMS AND TROUBLESHOOTING .....</b>	<b>90</b>
6.5.4.2 Dual Temperature Coil Cooling Operation .....	66	<b>9.1 ALARMS.....</b>	<b>90</b>
6.5.4.3 Dual Temperature Coil Heating Operation .....	66	9.1.1 Acknowledging Alarms .....	90
6.5.4.4 Dual Temperature Coil System Monitoring .....	67	9.1.2 Viewing Alarms and Alarm Log .....	90
<b>6.6 ECONOMIZER CONTROL (BYPASS/FREE COOLING).68</b>		9.1.3 Resetting Alarms .....	91
6.6.1 Economizer Based on Temperature Difference Sequence ...	69	9.1.4 Alarm Digital Outputs.....	91
6.6.2 Economizer based on Enthalpy Difference Sequence .....	69	9.1.5 Specific Alarms and Their Meaning.....	92
6.6.3 Economizer Based on OA Temperature Limits.....	70	9.1.5.1 General Alarms.....	92
6.6.4 Economizer Based on OA Enthalpy Limits .....	70	9.1.5.2 Supply and Exhaust Alarms .....	93
6.6.5 Modulating Bypass Settings.....	70	9.1.5.3 Airflow Condition Alarms.....	94
6.6.6 Monitoring the Modulating Bypass Status.....	70	9.1.5.4 Sensor Alarms .....	97
<b>7.0 SPECIAL FEATURES .....</b>	<b>71</b>	9.1.5.5 Filter Alarms .....	98
7.1 FROST CONTROL.....	71	9.1.5.6 Maintenance Alarms .....	98
7.2 SINGLE FAN MODE .....	72	<b>9.2 TEST END DEVICES.....</b>	<b>99</b>
7.3 LIMIT SETPOINT RANGES FOR USERS .....	72	9.2.1 Supply or Exhaust Fan Alarm Troubleshooting.....	99
7.4 ADJUSTMENTS FOR TWO-STAGE COOLING.....	73	<b>9.3 OTHER COMMON PROBLEMS.....</b>	<b>101</b>
7.5 TURN UNIT ON AND OFF BASED ON CO2 LEVEL.....	73	9.3.1 Unit Not On.....	101
7.6 FLUSH FEATURE .....	74	9.3.2 Sensor Reading #### or Has Extreme Value.....	101
7.7 COLD WEATHER OPERATION .....	74	9.3.3 BMS Loss of Comm after Param Change or Restore.....	101
7.8 SMOKE OR FREEZESTAT DEDICATED INPUT.....	76	9.3.4 Can Not See Device via IP Connection .....	101
7.9 BOOST MODE .....	77	<b>9.4 TESTING FUNCTIONS IN GENERAL.....</b>	<b>102</b>
7.10 H <sub>2</sub> O LEAK DETECT.....	77	<b>9.5 RESTORE PARAMETERS (SETTING) .....</b>	<b>102</b>
7.11 UNOCCUPIED OVERRIDE .....	78	9.5.1 User Commissioning Settings (Service).....	102
7.12 SMOKE PURGE .....	78	9.5.2 Restore Factory Settings .....	103
7.13 PREHEATER.....	78	9.5.3 General Save and Restore .....	103
7.14 SUMMER/WINTER CHANGEOVER.....	79	9.5.4 Code List for Save and Restore .....	104
7.15 SWAP AIRFLOWS .....	79	9.5.5 Return to Program Defaults.....	104
7.16 REFRIGERANT LEAK DETECTION MITIGATION .....	80	<b>10.0 ACCESSING FILES FROM AND</b>	
7.17 UNIT ON/OFF OUTPUT.....	80	<b>PERFORMING UPDATES TO</b>	
7.18 MULTIPLE CO2 SENSORS.....	81	<b>THE CONTROLLER .....</b>	<b>105</b>
7.19 ADDITIONAL HUMIDITY SENSORS .....	81	<b>10.1 CONNECTIONS USING THE MICRO USB PORT ....</b>	<b>105</b>
<b>8.0 VERIFYING I/O AND UNIT WIRING .....</b>	<b>82</b>	<b>10.2 ALARMS AND DATA LOGS .....</b>	<b>106</b>
8.1 VERIFYING ALL I/O THROUGH UNIT		10.2.1 Example of Alarm Log .....	106
STATUS SCREENS.....	82	10.2.2 Example of Data Log.....	106
		<b>10.3 VIEWING PARAMETER FILES .....</b>	<b>107</b>
		<b>10.4 PERFORMING UPDATES TO THE CONTROLLER ...</b>	<b>107</b>
		10.4.1 Upgrade Type: Connect via USB .....	108
		10.4.2 Upgrade Type: Connect with a USB Thumb Drive .....	108
		10.4.3 Upgrade Type: Connect via Ethernet .....	109

<b>11.0 GENERAL SYSTEM MONITORING</b>	<b>110</b>		
11.1 MAIN SCREEN .....	110		
11.2 OTHER STANDARD SCREENS .....	110		
11.3 FAN AND UNIT STATUS SCREENS .....	110		
11.4 FIELD-INSTALLED SENSOR SCREENS.....	111		
11.5 TEMPERING SCREENS .....	112		
11.5.1 Heating Screens .....	112		
11.5.2 Cooling Screens .....	112		
11.6 FROST CONTROL INFORMATION.....	113		
11.7 ENTRY TO THE I/O INFORMATION SCREEN.....	113		
11.8 VERSION INFORMATION SCREEN.....	113		
<b>12.0 BMS ACCESS</b>	<b>114</b>		
12.1 SETTING CONTROL LEVEL.....	114		
12.2 SETTING BMS TYPE.....	114		
12.3 BACNET .....	115		
12.3.1 BACnet IP Connection .....	115		
12.3.2 BACnet IP Settings.....	115		
12.3.3 BACnet MSTP Settings.....	116		
12.3.4 BACnet MSTP Wiring.....	116		
12.4 BACNET OBJECT LIST.....	117		
12.5 BACNET APPLICATION NOTES .....	123		
12.5.1 Turning the Unit On and Off .....	123		
12.5.2 Alarms.....	124		
12.5.3 Temperature and Humidity Around the ERV.....	124		
12.5.4 Fan Control.....	124		
12.5.5 BMS Direct Fan Control.....	125		
12.5.6 Tempering Control .....	126		
12.5.6.1 Determining Tempering Mode .....	126		
12.5.6.2 Heating Control.....	127		
12.5.6.3 Cooling Control .....	127		
12.5.6.4 Economizer Control .....	127		
12.5.7 Frost Control.....	127		
12.5.8 Filter Monitoring .....	128		
12.5.9 Exhaust Fan Only Mode.....	128		
12.6 ADDING A BACNET LICENSE.....	128		
12.6.1 Obtaining a BACnet License.....	128		
12.6.2 Installing the BACnet License via Web Page.....	128		
12.6.3 Installing the BACnet License via USB Drive.....	129		
12.6.4 Installing the BACnet License via USB Connection .....	129		
12.7 MODBUS .....	130		
12.7.1 Modbus TCP Connection .....	130		
12.7.2 Modbus TCP Settings .....	130		
12.7.3 Modbus RTU Settings .....	131		
12.7.4 Modbus RTU Wiring.....	131		
12.8 MODBUS REGISTER LIST .....	132		
12.9 MODBUS APPLICATION NOTES .....	134		
12.9.1 Turning the Unit ON and OFF .....	134		
12.9.2 Alarms.....	135		
12.9.3 Temperature and Humidity Around the ERV.....	135		
12.9.4 Fan Control.....	136		
12.9.5 BMS Direct Fan Control.....	136		
12.9.6. Tempering Control .....	137		
12.9.6.1 Determining Tempering Mode .....	138		
12.9.6.2 Heating Control.....	138		
12.9.6.3 Cooling Control .....	139		
12.9.6.4 Economizer Control .....	139		
12.9.7 Frost Control.....	139		
12.9.8 Filter Monitoring .....	139		
12.9.9 Exhaust Fan Only Mode.....	139		
<b>13.0 ADVANCED SERVICE</b>	<b>139</b>		
13.1 RUN HOURS AND STARTS .....	139		
13.2 LAST POWER LOSS.....	140		
13.3 INTERNAL MEMORY WRITES .....	140		
13.4 ALARM INITIALIZATION .....	140		
13.5 MEMORY WIPE .....	140		
13.6 COMMUNICATION TO EXPANSION MODULE.....	140		
<b>14.0 MAINTENANCE RECORDS</b>	<b>141</b>		
14.1 UNIT START UP CONDITIONS.....	141		
14.1.1 Setpoints.....	141		
14.1.2 Offsets.....	141		
14.1.3 IP Addresses .....	141		
14.2 CHANGES MADE TO UNIT AFTER START UP .....	142		
14.2.1 Setpoints .....	142		
14.2.2 Offsets .....	142		
14.2.3 I/O Configuration Changes .....	142		
14.3 CONTROLLER UPDATES .....	143		
14.4 SETTINGS BACKUP FILE.....	143		
<b>15.0 REFERENCE</b>	<b>144</b>		
15.1 TUNING PI CONTROL LOOPS .....	144		
15.1.1 Proportional Constant (KP).....	144		
15.1.2 Time Integral (Ti).....	145		
15.1.3 Establish a KP Setting .....	146		
15.1.4 Establish a Ti Setting.....	146		
15.1.5 Verify the Combined KP and Ti Settings .....	146		
15.2 TEMPERATURE SENSOR CURVE .....	149		
15.3 HE-SERIES FULL CONFIGURATION CODE .....	150		
15.4 LE-SERIES FULL CONFIGURATION CODE.....	152		
15.5 DN-SERIES FULL CONFIGURATION CODE.....	154		
15.6 CFM SCALING.....	156		
<b>16.0 GLOSSARY</b>	<b>158</b>		

**TABLE OF ILLUSTRATIONS**

Figure 1.3.0 Duct Temperature Sensor .....	12
Figure 1.4.0 Temperature and Humidity Sensor .....	12
Figure 1.5.0 Current Switch .....	12
Figure 5.1.3 Pressure Differential Transmitter (Typ) .....	13
Figure 1.7.0 Sensor Locations in ERV Units, HE10INV Shown.....	14
Figure 2.0.0 C.PCO Controller Buttons .....	15
Figure 2.0.1 Controller External Connections .....	15
Figure 2.0.2 Expansion Module Detail .....	16
Figure 2.0.3 Optional Remote User Terminal (RUT) Button Locations.....	16
Figure 2.1.0 Optional Remote User Terminal (RUT).....	17
Figure 2.1.1 Connecting a RUT .....	18
Figure 4.2.0 Sensor Wiring .....	26
Figure 4.2.1 CO2 Sensor (Duct Mount, Side View).....	27
Figure 4.2.2 CO2 Sensor (Wall Mount) .....	27
Figure 4.2.3 Pressure Differential Transmitter (Typ).....	28
Figure 4.2.4 Electrical Pressure Differential Transmitter .....	28
Figure 5.1.0 Smoke Detector.....	31
Figure 5.1.1 Motion Sensor (Ceiling Mount).....	32
Figure 5.1.2 Motion Sensor (Wall Mount) .....	32
Figure 12.2.0 Ethernet Connection .....	130
Figure 15.1.0 KP Setpoint Charts.....	145
Figure 15.1.1 KP Adjustment Worksheet .....	147
Figure 15.1.2 Ti Adjustment Worksheet .....	148



NOTE: This unit has a microprocessor controller. It is commonly referred to as a “controller.”



NOTE: Many of these control features require the use of optional sensors. The unit configuration will determine the availability of some functions.

## 1.0 OVERVIEW

### 1.1 CONTROL SEQUENCE OVERVIEW

The Renewaire ERV with premium controls provides outdoor air while saving energy by passing the exhaust air through the energy recovery core to exchange energy with the incoming air, with energy being passed to the incoming air in the winter and energy being passed to the outgoing air in the summer. Pairing this with the factory-programmed premium controller provides an excellent turn-key solution with the following control options.

1. Turning the unit off and on based on
  - A digital input (smoke detector, occupancy sensor, etc)
  - The controller keypad
  - Schedule
  - A BMS system, if the feature is enabled
  - CO2 level, if the feature is enabled
  - Alarm status
2. Isolation damper control (if option is included)
3. Supply and exhaust fan control
  - On/Off fan control for constant speed fans
  - Variable speed fan control for variable speed and ECM fans (set as a percentage)
  - Variable speed fan control for variable speed fans as a CFM reading
  - Supply or exhaust fan tracking
  - Fan control based on CO2 or VOC levels (with optional sensor added)
  - Fan control based on space or duct pressure levels (with optional sensor added)
  - Single fan operation with digital input or BMS command
4. Supply and Exhaust Fan status via current sensors
5. Monitoring of these values
  - Outdoor Air (OA) Temperature
  - Outdoor Air (OA) Relative Humidity
  - Return Air (RA) Temperature
  - Return Air (RA) Relative Humidity
  - Supply Temperature (SA) before tempering
  - Exhaust Temperature (EA)
  - Conditioned Air (CA) Temperature for units with tempering
  - Supply Air CFM
  - Exhaust Air CFM
  - User-supplied CO2 or VOC sensors
  - User-supplied Room or Duct Pressure sensors
6. Monitoring of pressure across filter for filter status (except DN units)
7. Bypass control for frost control/economizer control
8. Control for added heating (additional Conditioned Air Temperature sensor required)
  - 0–10V Gas or Electric
  - One- or two-stage Heat Pump
  - 10-0V Hot water valve control
  - Control based on Supply or Return Air
  - Setpoint can be reset off Outdoor Air temperature
9. Control for added cooling (additional Conditioned Air Temperature sensor required)
  - 0–10V chiller water valve
  - One- or two-stage compressor/heat pump
  - Control based on Supply or Return Air
  - Discharge setpoint can be reset off return air
10. VRF Control Sequence

11. Dual Temp Coil (using BMS command or digital input for heat/cool signal)
12. Alarm alerts and logging

## 1.2 ENERGY RECOVERY BASICS

### IMPORTANT

It is important to understand and use the equipment airstream terminology as it is used in this manual. The airstreams are defined as:

- ♦ Outside Air (OA): Air taken from the external atmosphere and, therefore, not previously circulated through the system.
- ♦ Supply Air (SA): Air that is downstream of the enthalpic cores and is ready for conditioning.
- ♦ Conditioned Air (CA): Air that is supplied to an occupied space.
- ♦ Return Air (RA): Air that is returned from a conditioned space.
- ♦ Exhaust Air (EA): Air that is discharged. Each ERV unit has an EA outlet.

RenewAire energy recovery ventilators use static-plate, enthalpy-core heat exchangers that have no moving parts.

- ♦ During summer months, the hot and humid OA passes by the cooler, drier RA, lowering its temperature and humidity.
- ♦ During winter months, the cold and dry OA passes by the warmer, moister RA, raising its temperature and humidity.

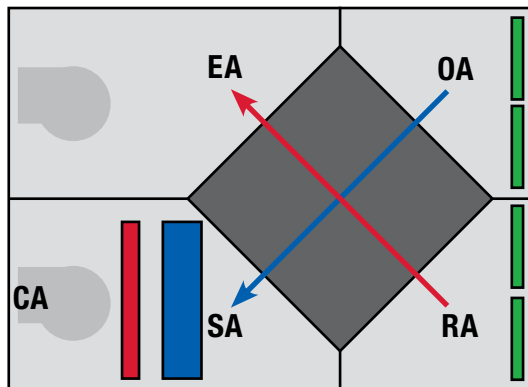

## 1.3 TEMPERATURE SENSORS

There are multiple temperature sensors installed in each ERV. These are NTC sensors that have a Carel curve. The curve characteristics can be found in the Reference section. They are located at:

- ♦ One in the EA section
- ♦ One in the SA section

If a unit has heating and/or cooling, there is also an additional CA sensor that is required. It needs to be installed down the duct past the heating and cooling.



**NOTE:** If an optional internal heating device is selected the CA duct sensor may need to be installed at least three duct diameters away from the ERV unit CA outlet.



FIGURE 1.3.0 DUCT TEMPERATURE SENSOR

### 1.4 COMBINATION TEMPERATURE AND HUMIDITY TRANSDUCERS

Temperature and humidity transducers are mounted in the OA and RA compartments and provide a temperature sensor output and a 0-10 VDC output that is proportional to 0–100% Relative Humidity.



FIGURE 1.4.0 TEMPERATURE AND HUMIDITY SENSOR

### 1.5 CURRENT SENSORS

Current sensors are installed on high voltage supply wires to sense current going to a fan motor. They are used to prove the ON/OFF state of fan motors.



**NOTE:** Current sensors are calibrated for reduced fan speed at time of shipment from the factory. Immediately after entering new operating parameters for the fans (done during the start up process), current sensors are to be re-calibrated for minimum current draw. The fan should be running at its minimum speed that will be experienced during normal operation.



FIGURE 1.5.0 CURRENT SWITCH

When the unit starts, this screen will show when the fans are enabled. There is a slight delay of a few seconds, and then the second line, *supply (or exhaust) fan on* shows the status of the current sensor.

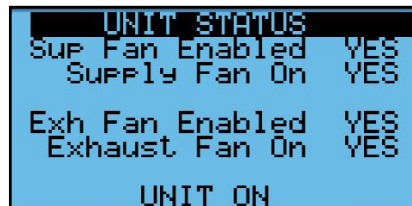

The current sensors are factory adjusted and may need to be field-adjusted for the application. This will be evidenced by getting a supply fan alarm (AL10) or exhaust fan alarm (AL11). The instructions are in the Alarms and Troubleshooting section of this manual.

### 1.6 FILTER MONITORING

There is a pressure transducer across the filters on the OA and RA streams to monitor the filter status. The scaling is factory set in this screen.



```

I/O Configuration
Filter Press Scaling
OA Flt 0 U= 0.0"wg
          10 U= 2.0"wg

RA Flt 0 U= 0.0"wg
          10 U= 2.0"wg
    
```

The alarm level is set in this screen. This alarm does not stop the unit from running.

```

ALARM SETTINGS
Filter Alarms
OA Level 1.0"wg
RA Level 1.0"wg
Alarm Delay 60 sec
    
```

You can also see the pressure in this screen so that if it gets close to the alarm level you can change it at your convenience.

```

UNIT STATUS
OA Humidity 25.0%
RA Humidity 22.3%
OA Enthalpy 21.8btu/lb
RA Enthalpy 21.3btu/lb
OA Filter 0.02"wg
RA Filter 0.05"wg
SA Temperature 68.7f
    
```

### 1.7 AIRFLOW MONITORING

For ERV units, two pressure transmitters that measure up to 1" w.g. are installed across the energy recovery core and are used to measure pressure drop. The scaling screen can be found in the *I/O Configuration*. The scaling is factory set for the fans and should only be adjusted during test and balance. Default values are shown in the appendix. The supply and exhaust flow values can be read in the *Unit Status* screens. DN units are measured with a 0-20" pressure transducer that measures the pressure across the fan and use a k Factor to determine flow. See the Appendix for the scaling of the CFM reading.



FIGURE 5.1.3 PRESSURE DIFFERENTIAL TRANSMITTER (TYP)

```

UNIT STATUS
SA Flow Rate 4301cfm
EA Flow Rate 4095cfm

RA Dewpoint 39.6f
OA Dewpoint 42.3f

Clg Coil LAT 52.7f
    
```

1.7 SENSOR LOCATIONS

**NOTE:** Not shown here are the Smoke Detector, CO2, IAQ, Duct Pressure Sensor, Room Temperature and Humidity Sensor, and Motion Detector. These items are all accessories and are field-installed.

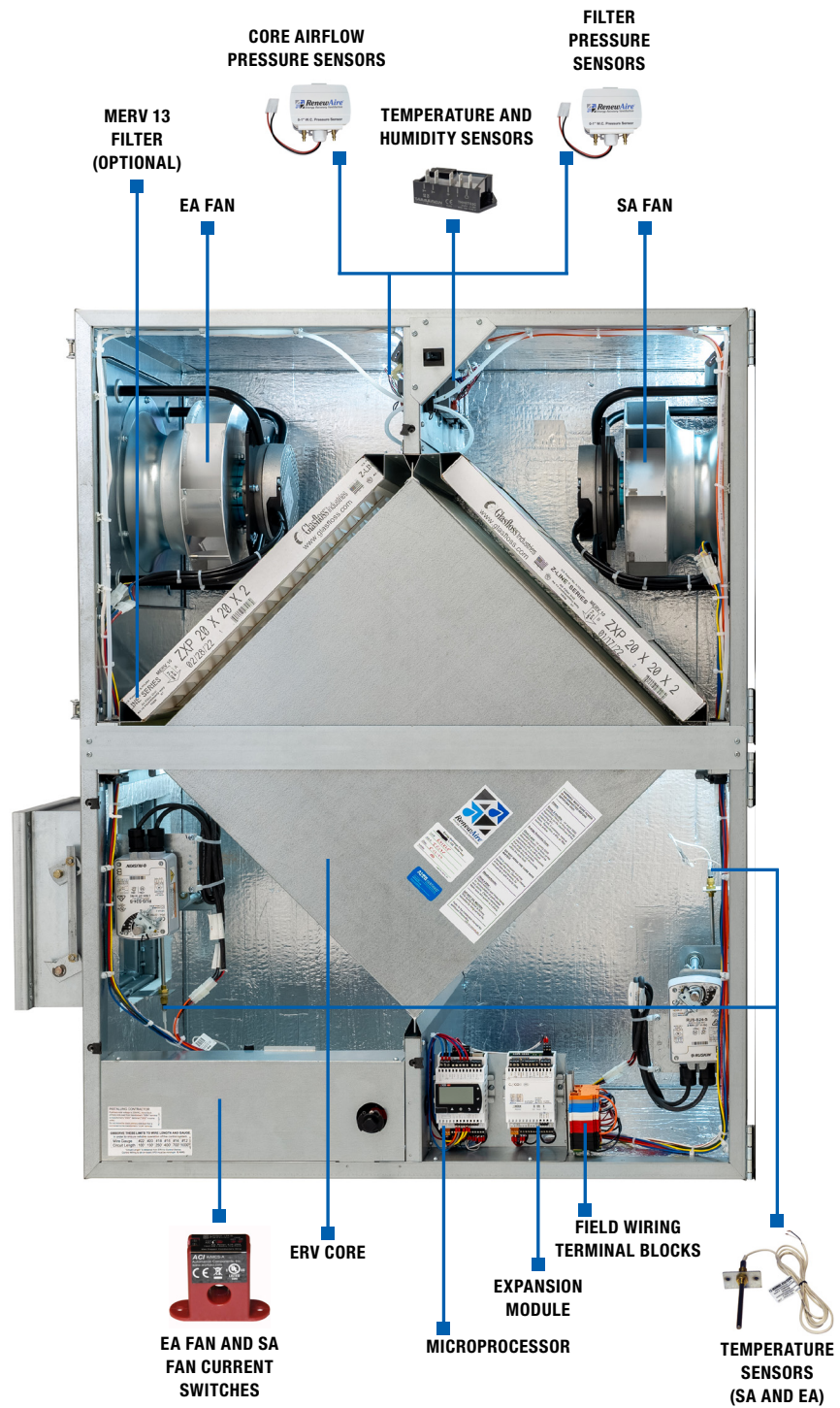
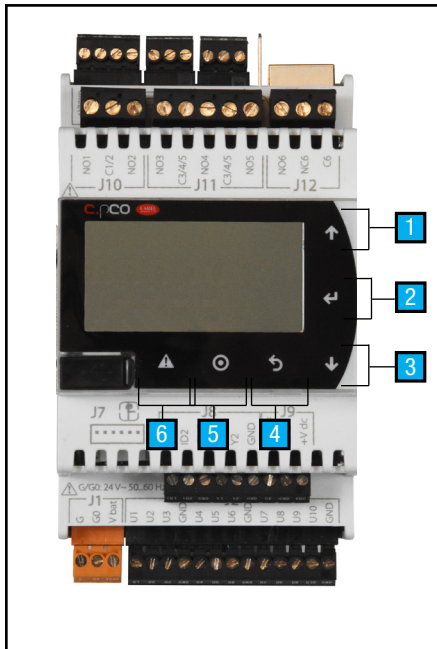

FIGURE 1.7.0 SENSOR LOCATIONS IN ERV UNITS, HE10INV SHOWN

## 2.0 CONTROLLER OVERVIEW

The control utilizes the Carel c.pco (pronounced see-pee-ko) controller with the c.pcoe expansion module.



1	Up Button
2	Enter Button
3	Down Button
4	Escape Button
5	Program Button
6	Alarm Button

FIGURE 2.0.0 C.PCO CONTROLLER BUTTONS

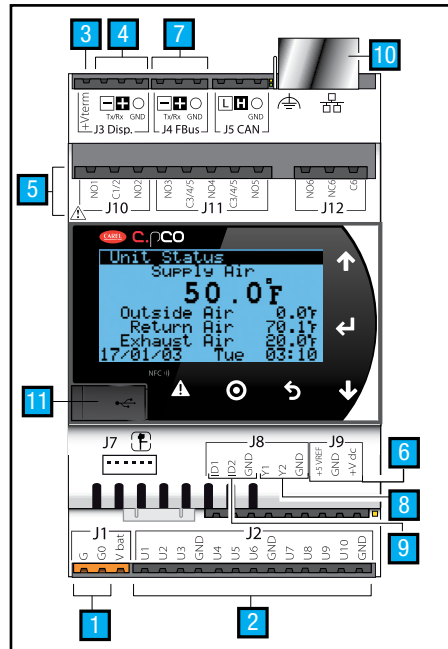

1	24VAC Power
2	Universal inputs/outputs
3	Power for RUT remote display
4	Remote display or BMS connection
5	Relay digital outputs
6	+5V power supply
7	FBUS connection to expansion module
8	Analog outputs
9	Digital inputs
10	Ethernet port
11	Micro USB port

FIGURE 2.0.1 CONTROLLER EXTERNAL CONNECTIONS

**NOTE:** Expansion module DIP switches are factory set to address 5, No Off-set, 19.2K, and Modbus. These settings should not be changed.

**NOTE:** Dip switch positions (Left to Right) are always set as follows:  
 Forward  
 Backward  
 Forward  
 Backward  
 Forward  
 Forward  
 Forward  
 Forward

The c.pCOe expansion module has multiple digital and analog inputs and outputs, serving as an extension of the controller. The expansion board provides:

- Heating and Cooling Control
- Monitor Airflow Rates, Temperatures, and Pressures

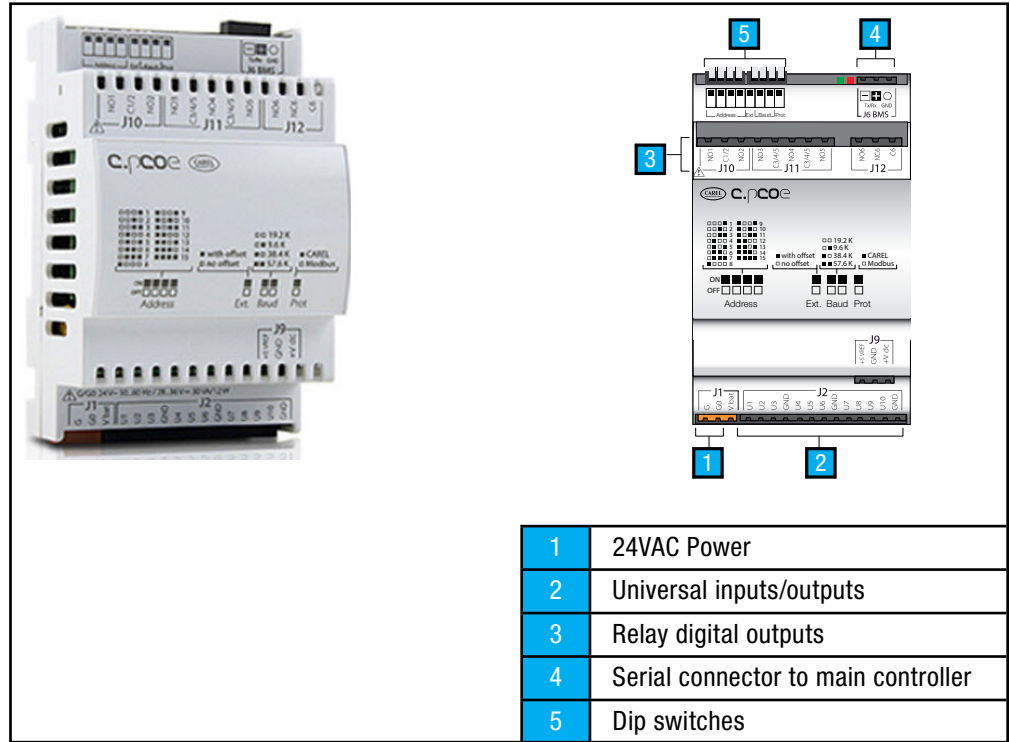

FIGURE 2.0.2 EXPANSION MODULE DETAIL

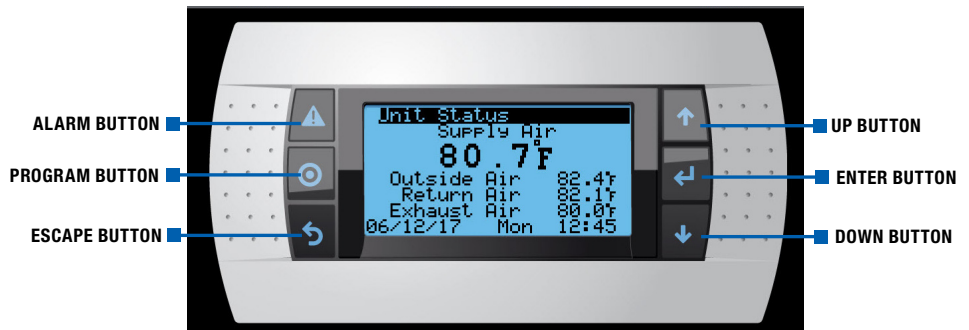

FIGURE 2.0.3 OPTIONAL REMOTE USER TERMINAL (RUT) BUTTON LOCATIONS



Pressing the PRG (program) button accesses the Service Menu or Login screen from any location in the user interface screens. The options that are available dynamically change depending on the configuration of the unit and the options installed on the unit.



The ESC button is used to go one level back from the screen the user is currently on. If the user is finished setting variables in a sub-menu, the ESC button takes them back to the previous menu. If the user is editing a variable and decides to not make a change, the ESC button takes them back to the top of that screen. Pressing the ESC button from the Main Menu takes the user back to the Main Status screen.



When on a screen with the cursor in the upper left-hand corner, the UP or DOWN hard buttons move the user from one screen to the next. While editing a variable, the UP or DOWN hard buttons allow the user to set the desired value of the variable. When viewing a view only variable, the UP or DOWN hard buttons scroll through the values available to the user.



When a menu or menu item has been highlighted, press the “ENTER” hard button to enter the highlighted selection. When a writable entry has been changed, press the hard button to enter the new value and then press it again to confirm the change.



Pressing the ALARM button displays any alarms that are currently active. There may be multiple screens of alarms. Pressing and holding the Alarm button for three seconds resets the alarms.



**NOTE:** When an alarm is first detected, the Alarm button will be flashing and an audible alarm will sound. After the alarm has been viewed, the light will remain on and the audible alarm will stop.

## 2.1 CONTROLLER ACCESS METHODS

The controller has a built-in display that can be used to set up the system and view the status of the system as well as address alarms. Two other options for accessing these are through the remote RUT and through the embedded web pages. All three methods use similar keys for the same purpose.

### 2.1.1 Using the Remote User Terminal (RUT)

The Remote User Terminal (RUT) allows you to plug into a controller and see the screens from that controller. RUTs are connected to the controller by means of a 10' cable and then used as hand-held devices. They can alternately be installed on a wall in some convenient location. The push buttons on the face of the RUT have the same functions as the push buttons on the controller.



FIGURE 2.1.0 OPTIONAL REMOTE USER TERMINAL (RUT)

The RUT (optional accessory, field-installed) plugs into the controller by means of a six wire cable with RJ12 jacks on each end. The six-wire cable is inserted in the RJ12 jack on the back of the RUT and the other end of the cable is inserted into the RJ12 adapter. The controller uses a pre-configured cable that plugs into the J3 jack on the controller and the other end is plugged into the RJ12 adapter. The cable looks similar to a standard phone cable but has a different pin out. The cable and coupler from the controller to the low voltage electrical box is included with the RUT.

**NOTE:** Common telephone wiring is 4 conductor and uses RJ11 terminals. It is different from the six-wire cable with RJ12 terminals needed for this accessory.

**NOTE:** If the controller was ordered for use with a serial BMS and an RUT is also desired, contact the factory for further information.

**NOTE:** For direct connection from RUT to J3 Terminal, use the following wiring:  
 Blue & White = +Vterm  
 Yellow & Black = GND  
 Green = Positive (+)  
 Red = Negative (-)

**NOTE:** The controller will only support private IP addresses which start with 192, 172, or 10.

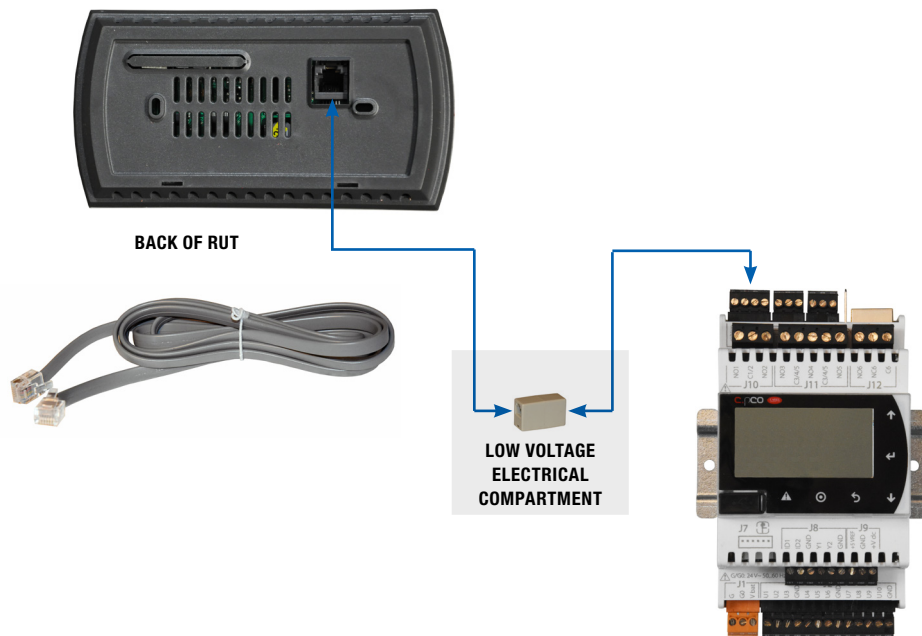

FIGURE 2.1.1 CONNECTING A RUT

2.1.2 Connecting Using Internal Web Pages

The controller has embedded web pages and when they are accessed, an interactive screen appears that allows the user to move through all the controller menus. The IP address of the controller is factory-set at 10.10.1.2. The subnet address (needed for setting up a LAN) is set at 255.255.255.0. These can be changed in the *General Settings* menu.

In order to connect to the controller with your pc you will need:

- An ethernet cable between the PC and the controller
- The PC connection must be on the same subnet as the controller. For example, if using the defaults, you would set the IP address of the PC connection to 10.10.1.xx where xx is not equal to 2, and the subnet to 255.255.255.0. (See directions for setting the PC IP address if you are not familiar with this.)

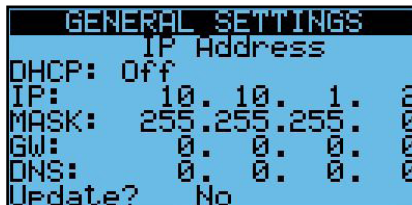

- Using a browser such as Chrome, put the controller IP address into the address bar.



You should see this web page. To get to the menu screens, click on RUT on the Menu Bar.



### 2.1.3 Setting the PC IP Address

For those that are not familiar with changing their PC adapter settings, go into Network Setting in the Control Panel and *Change Adapter Settings*.

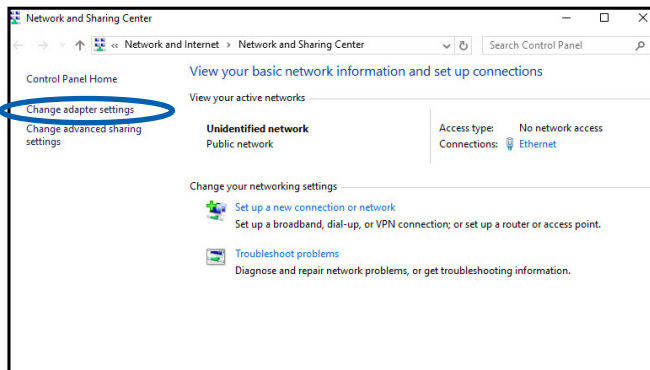

Choose the adapter you are using to connect to the controller.

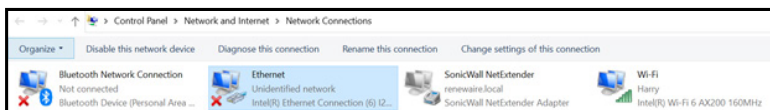

**NOTE:** When you are finished viewing the controller on your computer, remember to restore the original settings.

Select Internet Protocol 4 and click on Properties.

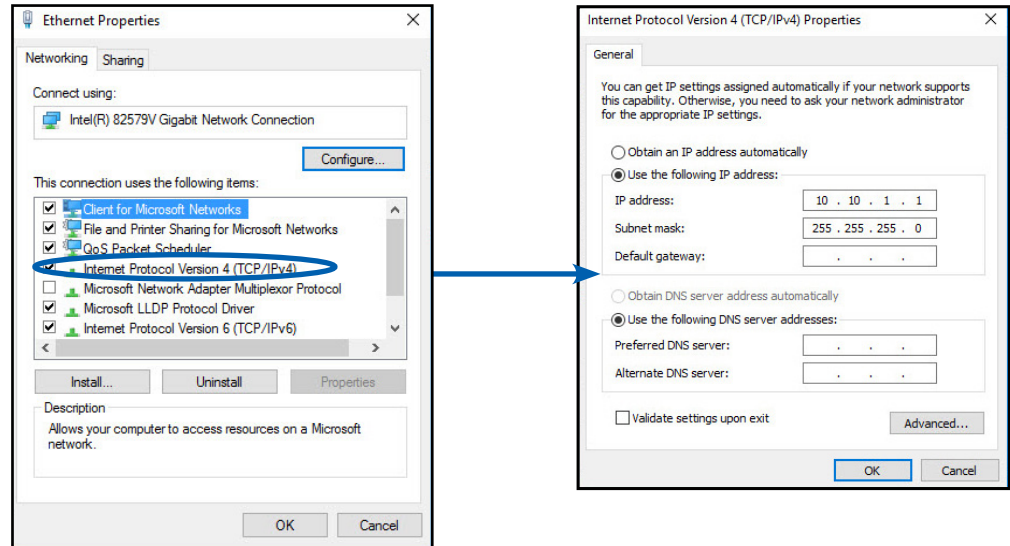

Enter the IP address you want to use. It should not be identical to the controller IP address. The last octet of the IP address should be different. Click OK.

2.1.4 Using the Multikey Function of the Web Pages

When you want to press multiple keys or press a key longer for a function you can use the keys below the Menu Screens to do this.

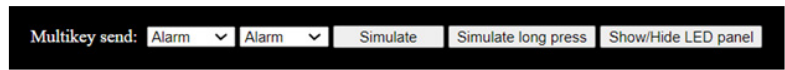

Two common uses are:

- Set the two keys to Alarm and Alarm and press *Simulate long press* to acknowledge alarms.
- Set the two keys to Alarm and Enter and press *Simulate long press* to get to system menus.

2.2 CONTROLLER MENU STRUCTURE

Any screen will have the name of the menu to which it belongs on the top line of the screen.

2.2.1 User Menu Structure

The user menu can be reached but pressing the ESC (back) button. The menus contain the following areas:

- *Unit Status*—Contains the status values of the sensors, fans, and heating and cooling, if applicable
- *Control Settings*—Contains the control settings for the fans and heating and cooling, if applicable
- *General Settings*—Contains the clock settings, Unit of Measures, IP Address, BMS settings, and the scheduler
- *Alarm Settings*—Contains the alarm settings
- *Unit On/Off*—Allows the user to turn the unit on and off via the keypad

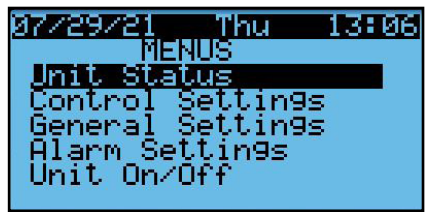

2.2.2 Password Protected Menu Structure

The password protected menu can be reached but pressing the PROG button and entering the password. The menus contain the following areas:

- Back Up and Restore—Contains the screens to back up your settings or return to factory defaults
- Unit Configuration—Main Unit Configuration Settings that determine which screens show up in other areas
- I/O Configuration—Secondary configuration settings for functions
- I/O Calibration—Allows sensors to be adjusted for accuracy
- Sensor Overrides—Allows a sensor value to be temporarily overwritten for testing
- Test End Devices—Allows outputs to be manually manipulated for troubleshooting
- Advanced Service—Advanced Service Information and Settings

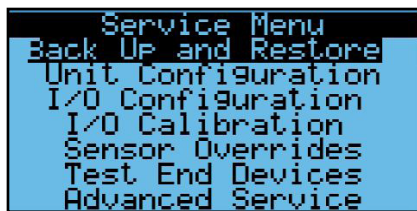

2.2.3 Password Entry

To access the password protected service screens, press the program (bullseye) button to get to the screen and enter the user password “1000.”



3.0 GENERAL FLOW FOR SETUP AND RUNNING UNIT

Depending upon features selected for the unit, the general flow for setup and running the unit is as follows:

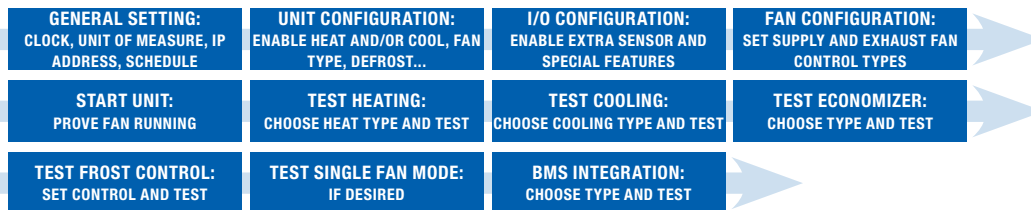

## 4.0 UNIT CONFIGURATION

### 4.1 CONFIGURE GENERAL SETTING

There are several general settings that are need for correct operation of the controller.

#### 4.1.1 Setting the Time and Date

It is important to have the correct time and date for alarm time stamps and logging.

- Set Refresh to YES, It will turn back to NO after changing the display to the current controller time and date.
- Change the Time ad Date accordingly. (Day is automatically generated.)



#### 4.1.2 Setting the Unit of Measure

The controller supports the following settings:

- SI (bar, Celsius)
- USA (psi, Fahrenheit)
- UK (bar, Celsius)
- CAN (psi, Celsius)

Set the Unit of Measure to the desired units for the display.



#### 4.1.3 Setting the IP Address of the Controller

The controller IP address may be used for the BMS, networking, or local access.

- Set the DHCP to OFF if using a static IP
- Set the IP address and Mask
- Set Update to YES
- Cycle power to the controller

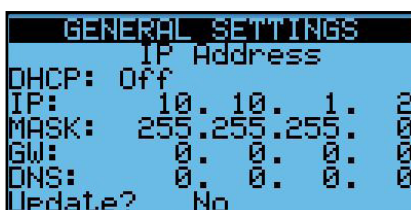

#### 4.1.4 Scheduler

Enable the scheduler, if desired. If you enable the scheduler, it will have to be set for “ON” for the unit to run along with all other “ON” conditions.

- Enable the scheduler by setting to YES.
- Set the schedule for each day. You can use the copy feature to copy days. Save data after each.
- Set vacation periods.
- Set Special Days.

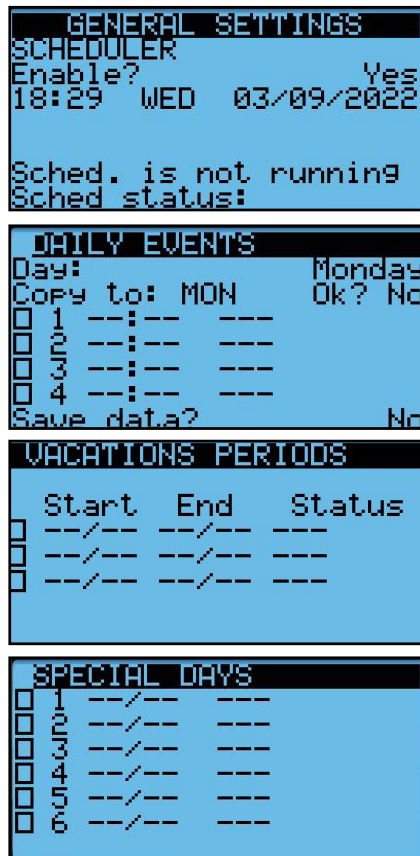

## 4.2 VERIFY UNIT CONFIGURATION

### 4.2.1 Main Unit Configuration

It is important to verify the configuration as the settings on the screen will also determine which screens show up in the user settings screens.

- Unit Type: Premium (or Premium RD if RD Unit)
- Bypass Damp: Disable/Enable
- BP Type: Two-Position if ERV, Modulating if DN
- BP Seq: Internal if ERV w/internal or DN, External if external bypass or rooftop bypass
- Isolation Damp: Disable/Enable
- Enable Heat: No/Yes
- Enable Cool: No/Yes

```

UNIT CONFIGURATION
Unit Type: Premium
Bypass Damp: Disable
BP Type: Two-Position
BP Seq: INTERNAL
Isolat Damp: Enable
Enable Heat: NO
Enable Cool: NO

```

If heating or cooling was enabled, you will also see this screen. The settings can be set here or in *Control Settings*.

```

UNIT CONFIGURATION
CLG TYPE:On/Off
HTG TYPE:On/Off

NOTE: CA Sensor is
required in the duct
downstream. PN 131318

```

If cooling was enabled, you will also see this screen. You can enable HGRH. If En 2Pos is set to NO, HGRH will be a 0–10 VDC output at U8 on the expansion module. Otherwise, it will be a two-position at NO2 on the expansion module. In either case, a coil leaving air temperature sensor is required. If the coil is factory installed, the sensor will be installed on U5 on the expansion module.

```

UNIT CONFIGURATION
En Mod HGRH: YES
En 2Pos HGRH: NO
If HGRH enabled, go to
I/O Config and set
Dehum changeover mode
and assign LAT sensor
to a free input.

```

If heating or cooling is enabled, the unit can control a recirculation damper for unoccupied times where it will maintain unoccupied setpoints. If factory-installed on a DN unit, it will be on U3 on the main controller. If it is installed external to any unit and the unit has two-position bypass on U3 on the main controller, a screen letting you know that you have to assign it to an open I/O in the *I/O Configuration*.

```

UNIT CONFIGURATION
Enable Recirculation
for unoccupied?
NO

Requires Recirc Option
or external dampers

```

```

UNIT CONFIGURATION
ATTENTION!!!
You have selected a
recirc option that
requires you to assign
the recirc damper to
an open digital output
in the I/O config

```

On this screen, if the fans are variable speed, these settings will be set to Yes.

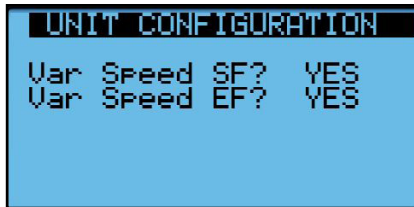

On this screen, if you want the unit to perform frost control, select YES. The units with modulating bypass will modulate to prevent frost while units without will cycle the supply fan to prevent frost. All of the settings are in the control settings area.

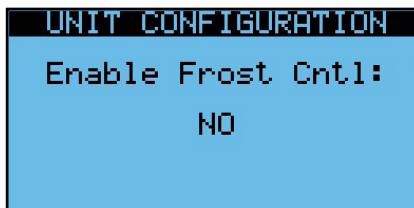

4.2.2 I/O Configuration

4.2.2.1 Digital Inputs

It is important to verify the configuration as the settings on the screen will also determine functionality and which screens show up in the user settings screens.

In this screen, set the use for the two digital inputs on the main controller. The defaults are shown. Consult the Special Features section for more information and additional settings for each function. The settings should be different.

- Choices for ID1: DI On/Off, Smoke Alarm, Freezestat, Boost Mode, Refrig Leak, VRF Defr CK1, VRF Defr CK2, H2O Leak Detect, Smoke Purge, Occ Override, Summer/Winter.
- Choices for ID2: Sing Fan Mode, Smoke Alarm, Freezestat, Boost Mode, Refrig Leak, VRF Defr CK1, VRF Defr CK2, H2O Leak Detect, Smoke Purge, Occ Override, Summer/Winter.

 NOTE: If this is a DN unit with a cooling coil, the unit will have a refrigerant leak detector on ID2.

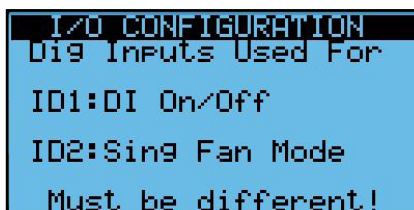

4.2.2.2 Analog Inputs

In this screen, set any of the standard sensors shown to YES. Each sensor will also have a screen in which you scale the input. Those are shown later in this chapter by the wiring diagrams.



 NOTE: U4 is not available in DN units that utilize modulating bypass.

For any of U3-U6 that are unused, you may set them up to receive signals for other sensors. Choices include SA Humidity, EA Humidity, Coil LAT, 2nd CO2, 3rd CO2, and 4th CO2.

See this chart for a summary of sensors for each flexible I/O.

INPUT	DEFAULT SENSOR	UNLESS USED FOR THIS	ALTERNATES
U3	CO2_Level if enabled		SA Humidity, EA Humidity, Coil LAT, 2nd CO2, 3rd CO2, 4th CO2
U4	VOC_Level if enabled not DOAS	Bypass_Command if DOAS	
U5	SpacePress if enabled		
U6	Duct_Press if enabled		
U7	CA_Temp		
U8	Disabled	HGRH Modulating	Preheater

In general, NTC sensors get wired from the corresponding Ux connection and GND on the expansion module, while active sensors get powered by the red din terminal and wire the "+" to the Ux and "-" to GND or the black terminal.

Any input not used for the "standard" by setting to YES, a screen will appear where you can set it to one of the other input types. See the *Special Features* section for uses of these additional sensors.

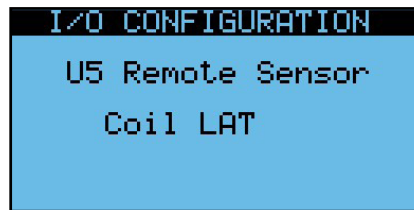

4.2.2.3 Field-Installed Sensors and General Wiring

All sensors are wired to DIN terminal (power and common) and to the universal input of the expansion module, as shown.

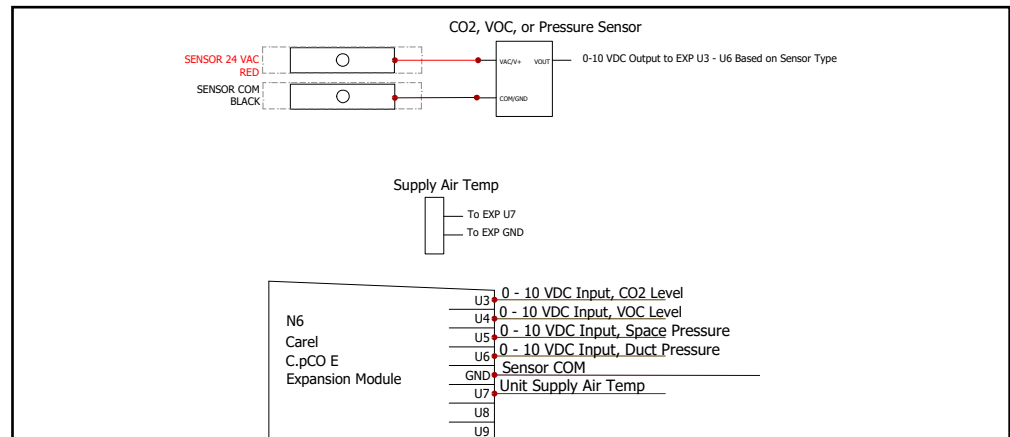

FIGURE 4.2.0 SENSOR WIRING

Field-installed control sensors and monitors are to be installed and wired in accordance with instructions shipped in the documentation package. Wire gauge must be in accordance with the following:

Wire Gauge	#22	#20	#18	#16	#14	#12
Circuit Length	100'	150'	250'	400'	700'	1000'

4.2.3 CO2/VOC Sensors

The ERV control allows the use of a CO2 sensor and/or a VOC sensor. The sensor may be physically attached to the system (Source = Hardware) or the value may be written from the BMS system (Source = from BMS).

The CO2 sensor is used as part of a demand control ventilation system to provide speed control of fans based on the level of CO2 in the space or duct. These sensors provide a 0–10VDC signal scaled as specified in the CO2 scaling screen.

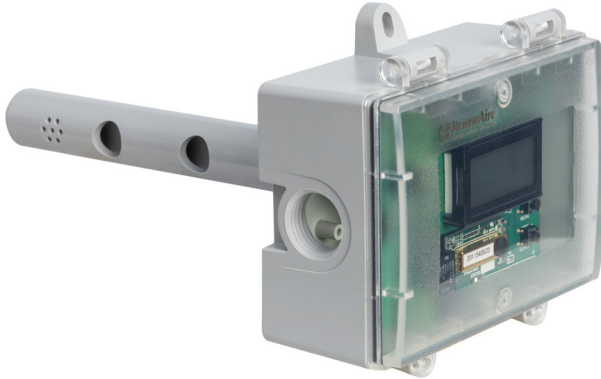
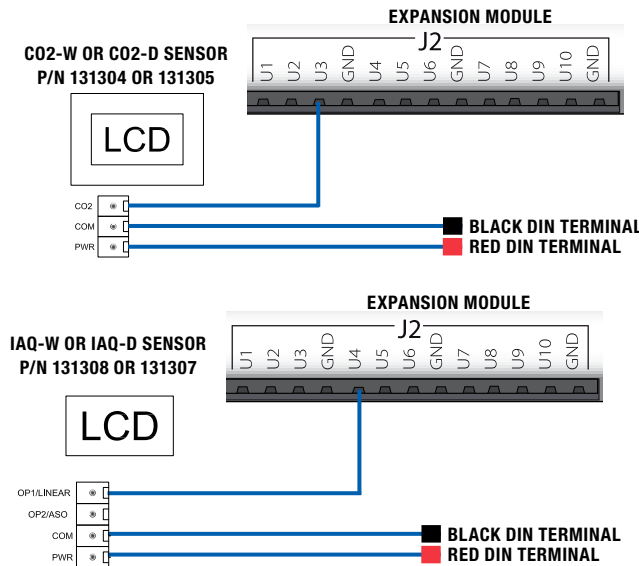
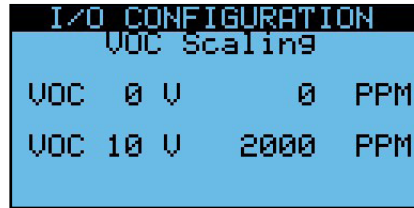
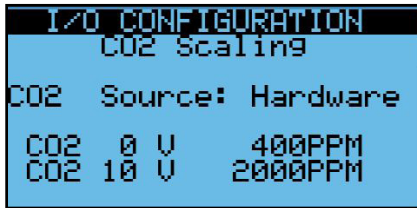

FIGURE 4.2.1 CO2 SENSOR (DUCT MOUNT, SIDE VIEW)



FIGURE 4.2.2 CO2 SENSOR (WALL MOUNT)

The Air Quality Monitor detects total VOCs (TVOC) in the supply airstream or the space. It uses a MEMs metal oxide semiconductor sensor to capture VOC emissions that are invisible to CO2 sensors. It is installed in the SA duct or the space. These sensors provide a 0–10VDC signal scaled as specified in the VOC scaling screen.



**NOTE:** When wiring the sensor, wire the sensor output directly to the expansion module, see Figure 4.2.0.

4.2.4 Differential Pressure Duct or Room Pressure Sensor

The pressure transmitter with a display screen (below right) is an optional accessory and would be installed in a duct to run the fan to meet a specific duct pressure. These sensors provide a 0–10VDC signal scaled as specified in the Duct Pressure scaling screen.

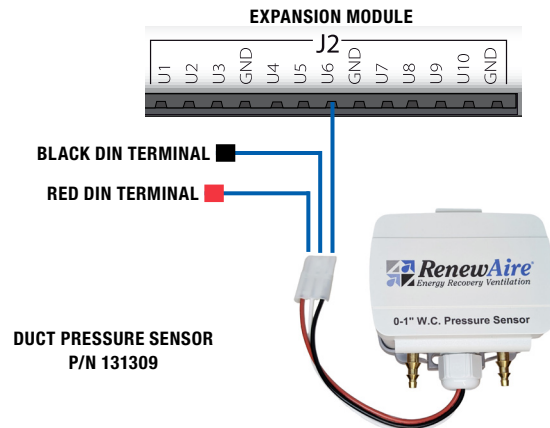

FIGURE 4.2.3 PRESSURE DIFFERENTIAL TRANSMITTER (TYP)



FIGURE 4.2.4 ELECTRICAL PRESSURE DIFFERENTIAL TRANSMITTER

**NOTE:** When wiring the sensor, wire the sensor output directly to the expansion module, see Figure 4.2.0.



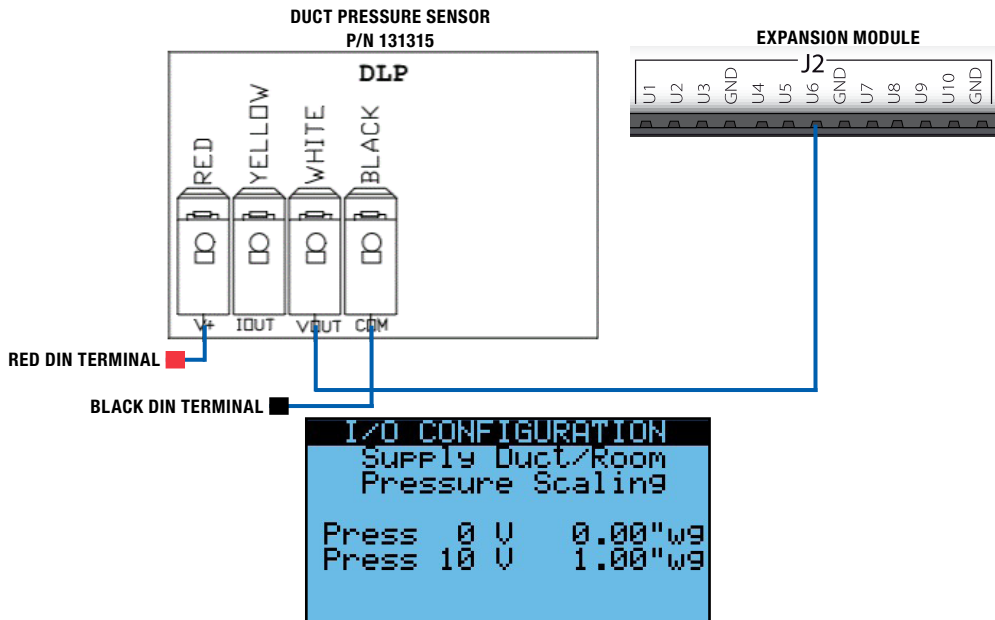

**NOTE:** When wiring the sensor, wire the sensor output directly to the expansion module, see Figure 4.2.0.

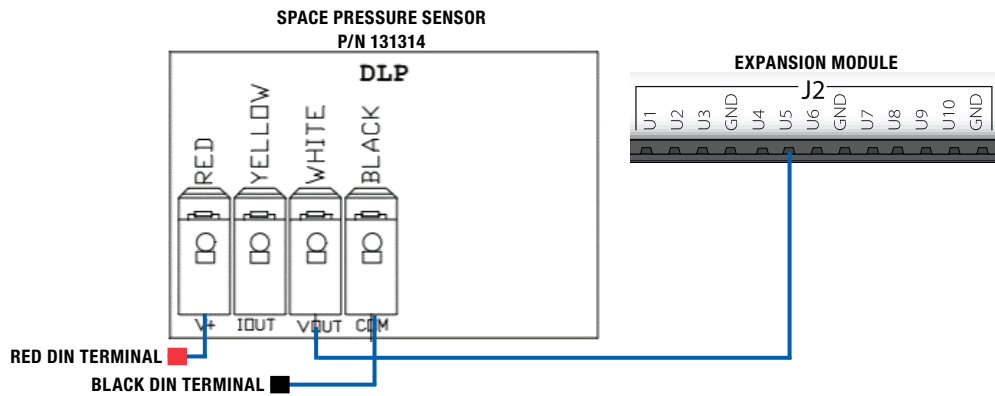

4.2.5 CA Temperature Sensor

The CA Temperature sensor is automatically enabled if the heating and/or cooling is enabled. If it is not connected, an alarm will occur. If your unit was ordered with heating and/or cooling, the supply temperature sensor should be included but may need to be installed down the duct to prevent cycling of heating or cooling. The sensor uses a special curve and cannot be swapped with standard T2 or T3 NTC sensors.

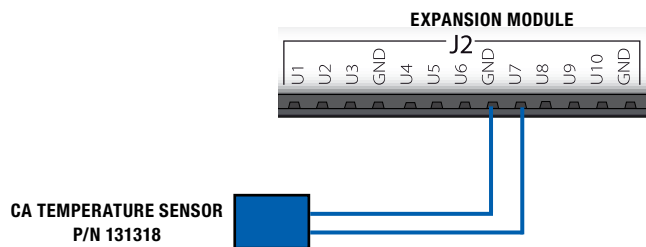

**NOTE:** When wiring the sensor, wire the sensor output directly to the expansion module, see Figure 4.2.0.

### 5.0 UNIT OPERATION AND FAN CONTROL

The primary purpose of the ERV unit is to provide 100% OA. The amount of air that it provides is based on the configuration of the supply and exhaust fans and whether the unit is running or not.

Fans are either controlled with variable speed drives or ECM motors.

#### 5.1 SEQUENCE OF OPERATION FOR UNIT START

The unit will start when all of the following conditions are true:

- There are no serious alarms.
- The Digital Input for start/stop (orange DIN terminal to black DIN terminal) are closed if ID1 is set for DI On/Off.
- The unit is turned on at the keypad.
- The time is within the scheduler “ON” time, if scheduler enabled.
- The BMS has written the unit on signal, if BMS control is enabled.



Upon starting, the isolation dampers will open. The end switches of these dampers will complete the Fan Enable signal to the ECM or VFD fans.

Once the fan enable signal is complete, the fan command signal will be sent to the fan after the start up delay time. Each fan is paired with a current sensor. If within the alarm delay time, default 90s, the current sensor does not detect the fan running, the unit will shut down and an alarm will occur.

The alarm setting *SF Alarm Unit Run?* setting tells whether the unit, and thus the exhaust fan, will continue to run if there is an alarm with the supply fan.

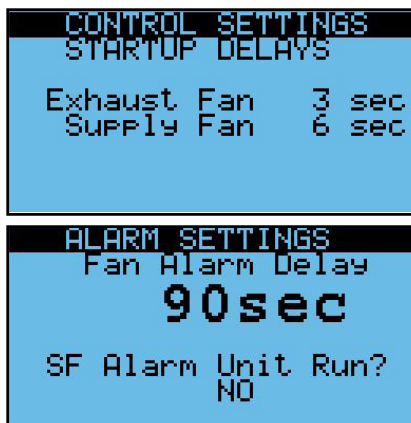

The Unit status is shown on the bottom of this screen. More than one of these statuses may be valid at one time

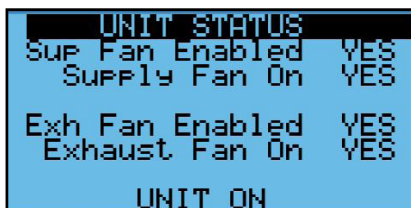

UNIT STATUS CONDITIONS	
STATUS SHOWN	MEANING
Unit on	Unit is on in normal operation.
Off by alarm	Unit is off by alarm condition.
Off by BMS	Unit is off by BMS command (and BMS control is enabled).
Off by DI	Unit is off by digital input ID1.
Off by Keyboard	Unit is off by the switch through the menu screens.
Manual UNOCC	Unit is commanded to unoccupied (Sensor Overrides).
EF Only Mode	Unit is in exhaust fan only mode by either ID2 or BMS.
SF Only Mode	Unit is in supply fan only mode by either ID2 or BMS.
IUNOCC Mode	Unit is in unoccupied mode by BMS or scheduler.
BMS Cool Lockout	BMS Heat/Cool enabled and Cooling is locked out.
BMS Heat Lockout	BMS Heat/Cool enabled and Heating is locked out.
In Device Test	Unit is in Device Test Mode.
Input Overwritten	An input is overwritten in the Sensor Overrides section.
Off by CO2 Level	Unit is off by CO2 Level.
Flush Mode	Unit is in flush mode by scheduler.
Frost Control On	Frost Control mode is on.
In Boost Mode	Unit is in Boost mode by digital input.
Smoke Purge	Unit is in Smoke Purge mode by digital input.
VRF Defrost	Unit is in defrost mode by the VRF system.
Econ Active	Economizer Bypass is Active.
On by Override	In occupied mode by digital input override.
Off on Low Temp	Off by low temp (Low SA settings).
EF Only Low Temp	Exhaust fan only by low temp (Low SA settings).

5.1.1 Digital Input (ID1) Unit On/Off

The digital input ID1 must be connected to COM to turn the unit on. The orange factory jumper can be left in place if this feature is not used. Some of the uses are a remote switch, a smoke detector or a motion/occupancy sensor. Shown are the accessories are offered by RenewAire.

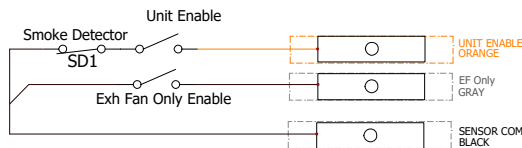

To use the unit enable input or smoke detector remove the orange factory jumper

5.1.1.1 Optional Smoke Detector

Normally field-installed on the discharge duct, near the furnace.



FIGURE 5.1.0 SMOKE DETECTOR

**NOTE:** Some units use ID1 as the door kill switch. Consult your unit's wiring diagram.

**NOTE:** ID1 can be used for alternate functions, set in the I/O Configuration.

5.1.1.2 Optional Motion Sensor

Used for occupancy-based ventilation, hardwired to the low-voltage terminal strip.



FIGURE 5.1.1 MOTION SENSOR (CEILING MOUNT)



FIGURE 5.1.2 MOTION SENSOR (WALL MOUNT)

5.1.2 Isolation Dampers

The ERV unit has optional isolation dampers with end switches. DN-Series units come with these as standard. For more information consult the unit specific IOM.

5.1.3 Fans

The variable speed fans may be driven by VFDs or may be ECM fans. The VFD fans get an enable signal and both types of fans get a 0–10VDC signal which is proportional to 0–100% fan command.

Factory VFD settings should not be changed. The settings are available in the *Reference* section of this manual.

**5.2 OPTIONS FOR SUPPLY FAN CONTROL**

Units with a VFD or ECM for the supply fan can control the fan for constant speed, SA flow control, supply duct static pressure control, room static pressure control, CO2 control, VOC control, or CO2 Flow control. Available modes may depend on the sensors added.

5.2.1 Constant Fan Speed Option

The analog voltage command to the supply fan VFD or ECM can be set from the unit controller display or by the BMS. The adjustable range of 0% to 100% correspond to the minimum and maximum fan operating speed.

 **NOTE:** It is possible to have the BMS control the fan directly. Refer to the BMS section for more information.

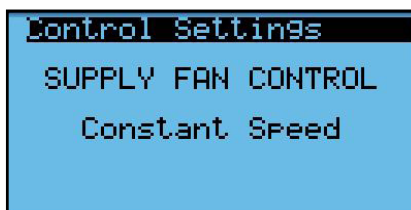

This supply fan operation mode can be used to field balance the SA flow rate.

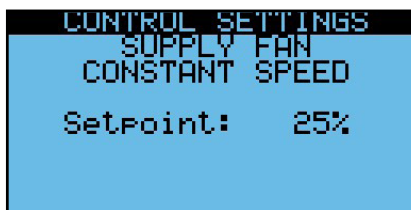

### 5.2.2 SA Flow Control Option

The controller will adjust the supply fan VFD or ECM command to maintain the SA flow rate at a setpoint.



The SA flow rate setpoint is entered and adjusted from the unit controller display or provided by the BMS. The minimum and maximum values for SA flow rate setpoint are unit dependent. An adjustable proportional and integral (PI) loop will compare the measured SA flow to the airflow rate setpoint and adjust the fan speed. If the measured SA flow rate varies from the desired airflow rate by more than 10% (adjustable) for more than 60 seconds (adjustable) a SA flow rate alarm will be set to true. This supply fan operation mode can be used to provide a constant SA flow rate as the unit filters become loaded.

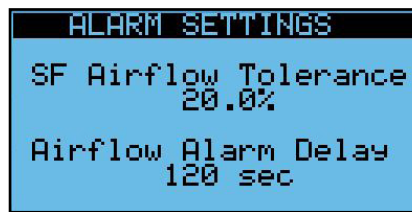
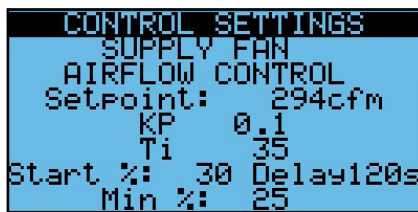

### 5.2.3 Supply Duct Static Pressure Control Option

The controller will adjust the supply fan VFD or ECM command to maintain the supply duct static pressure at a setpoint. This option requires a field-installed duct pressure transmitter and setup for the transmitter in the I/O configuration.



The SA duct static pressure setpoint is entered and adjusted from the unit controller display or provided by the BMS. The minimum and maximum values for SA duct static pressure setpoint are unit dependent. An adjustable PI loop will compare the measured SA duct static pressure to the static pressure setpoint and adjust the fan speed. If the measured static pressure varies from the desired static pressure by more than 0.05" w.g. (adjustable) for more than 60 seconds (adjustable) a SA static pressure alarm will be set to true. This supply fan operation mode can be used to provide a constant supply duct pressure for VAV systems.

```

CONTROL SETTINGS
SUPPLY FAN
DUCT STATIC CONTROL
Setpoint 0.50"wg
KP 200.0
Ti 25
Start %: 30 Delay120s
Min %: 25
    
```

```

ALARM SETTINGS
SF Duct Press Tol
110.0%
>100% disables alarm
Pressure Alarm Delay
300 sec
    
```

```

ALARM SETTINGS
SF Duct Press Alarms
En Low Press Alrm? NO
Alarm Level: 0.0"wg
En High Press Alrm NO
Alarm Level: 5.2"wg
Pressure Alarm Delay
300 sec
    
```

5.2.4 Room Static Pressure Control Option

The controller will adjust the supply fan VFD or ECM command to maintain the room static pressure at a setpoint. This option requires a field-installed room pressure transmitter and setup for the transmitter in the I/O configuration.

```

Control Settings
SUPPLY FAN CONTROL
Room Static
    
```

The room static pressure setpoint is entered and adjusted from the unit controller display. The minimum and maximum values for room static pressure setpoint are unit dependent. An adjustable PI (proportional & integral) loop will compare the measured room static pressure to the static pressure setpoint and adjust the fan speed. If the measured static pressure varies from the desired static pressure by more than 0.05" w.g. (adjustable) for more than 60 seconds (adjustable) a room static pressure alarm will be set to true. This supply fan operation mode can be used to provide a constant static pressure in an area to control infiltration or exfiltration from an adjacent area or outdoors.

```

CONTROL SETTINGS
SUPPLY FAN
ROOM STATIC CONTROL
Setpoint 0.050"wg
KP 100.0 Ti 30
Min Command 15.0%
Max Command 100.0%
Start %: 30 Delay120s
    
```

```

ALARM SETTINGS
SF Room Press Tol
10.0%
Pressure Alarm Delay
300 sec
    
```

```

ALARM SETTINGS
SF Duct Press Alarms
En Low Press Alrm? NO
Alarm Level: 0.0"wg
En High Press Alrm NO
Alarm Level: 5.2"wg
Pressure Alarm Delay
300 sec
    
```

5.2.5 CO2/VOC Control Option

The controller will adjust the supply fan VFD or ECM command to maintain the room or RA CO2 or VOC level at a setpoint. This option requires a field-installed CO2 and/or VOC sensor or value from a BMS and setup for the sensor in the I/O configuration.

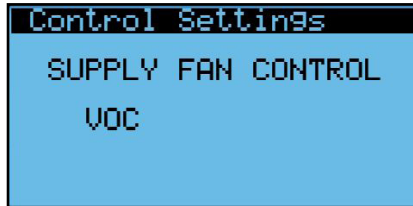

The CO2/VOC setpoint is entered and adjusted from the unit controller display or provided by the BMS. An adjustable PI loop will compare the measured CO2/VOC level to the CO2/VOC setpoint and adjust the fan speed. The minimum and maximum fan speed commands are adjustable. If the measured CO2/VOC level exceeds 1000 ppm (adjustable) for more than 60 seconds (adjustable) a CO2/VOC alarm will be set to true. This supply fan operation mode can be used to provide demand-controlled ventilation of a space. The minimum fan speed will provide the required minimum outdoor air when the CO2/VOC level is at or below the CO2/VOC setpoint.

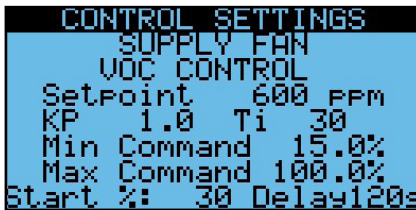

5.2.6 CO2 Flow Control Option

The controller will adjust the supply fan VFD or ECM command based on the measured room or RA CO2 level.



The SA flow setpoint is derived from the user entered minimum and maximum CO2 levels and minimum and maximum desired airflow rates. When the CO2 level is at or below the minimum CO2 level the airflow setpoint is at the minimum and when the CO2 level is at or above the maximum CO2 level the airflow setpoint is at the maximum. Between the minimum and maximum CO2 levels the airflow setpoint is linearly scaled. If the measured CO2 level exceeds 1000 ppm (adjustable) for more than 60 seconds (adjustable) a CO2 alarm will be set to true. This supply fan operation mode can be used to provide demand-controlled ventilation of a space. The minimum fan speed will provide the required minimum outdoor air when the CO2 level is at or below the CO2 setpoint.

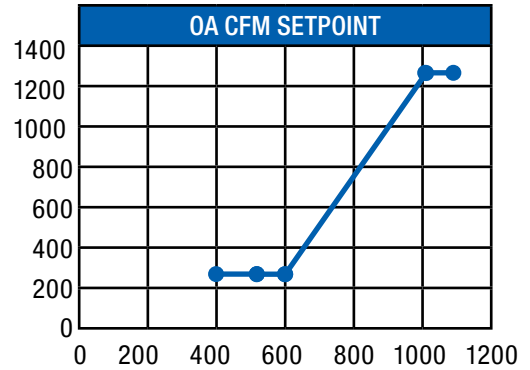
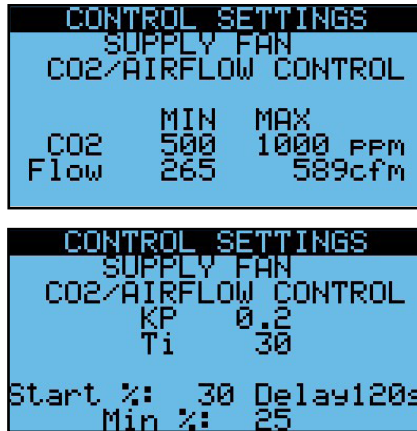

Because the flow cannot be calculated in bypass, the following setting will be used for bypass mode.

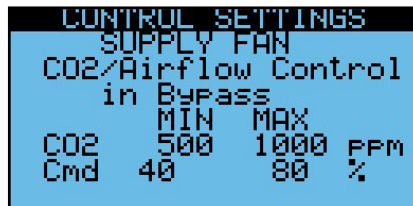

5.2.7 Exhaust Fan Command Tracking Control Option

The controller will adjust the supply fan VFD or ECM command to track the exhaust fan VFD or ECM command.



The minimum (50%) and maximum (200%) tracking rates are adjustable. This supply fan operation mode can be used to maintain proportional supply and exhaust fan commands as the exhaust fan modulates.

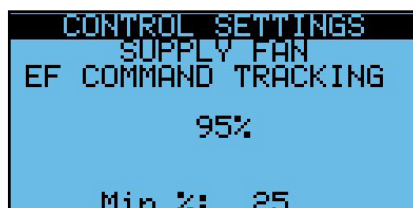

### 5.2.8 Exhaust Fan Flow Tracking Control Option

The controller will adjust the supply fan VFD or ECM command to track the exhaust fan air flow rate.

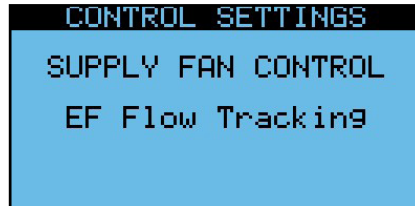

The offset from the EA flow rate is adjustable from -25% to +25%. An adjustable PI loop will compare the measured EA flow to the airflow rate setpoint and adjust the fan speed. This supply fan operation mode can be used to maintain proportional supply and exhaust flows as the exhaust fan modulates and as the unit filters become loaded.

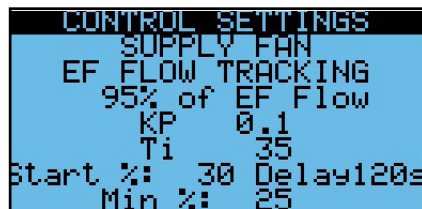

An additional setting is required for economizer bypass in units with two-position bypass.

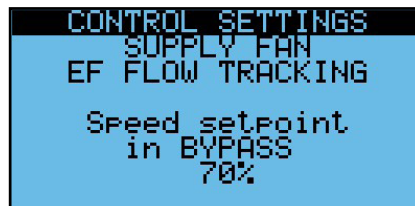

## 5.3 OPTIONS FOR EXHAUST FAN CONTROL

Units with a VFD or ECM for the exhaust fan can control the fan for fixed speed, EA flow control, supply fan command tracking control, supply fan flow rate tracking control, or room static pressure control.

### 5.3.1 Constant Fan Speed Option

The analog voltage command to the exhaust fan VFD or ECM can be set from the unit controller display or by the BMS.

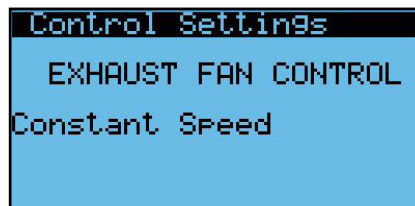

The adjustable range of 0% to 100% correspond to the minimum and maximum fan operating speed. This exhaust fan operation mode can be used to field balance the EA flow rate.



**NOTE:** It is possible to have the BMS control the fan directly. Refer to the BMS section for more information.

If using boost input, this screen will also appear prompting you to select a command for Boost Mode.

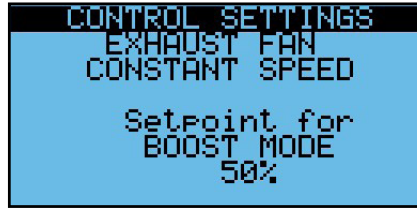

5.3.2 EA Flow Control Option

The controller will adjust the supply fan VFD or ECM command to maintain the EA flow rate at a setpoint.



The EA flow rate setpoint is entered and adjusted from the unit controller display or provided by the BMS. The minimum and maximum values for EA flow rate setpoint are unit dependent. An adjustable PI loop will compare the measured EA flow to the airflow rate setpoint and adjust the fan speed. If the measured EA flow rate varies from the desired airflow rate by more than 10% (adjustable) for more than 60 seconds (adjustable) an EA flow rate alarm will be set to true. This exhaust fan operation mode can be used to provide a constant EA flow rate as the unit filters become loaded.

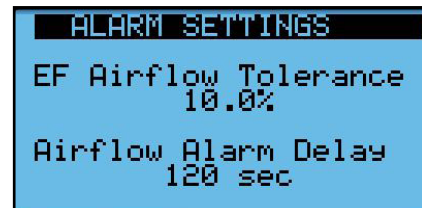

If using boost input, this screen will also appear prompting you to select a command for Boost Mode.



Because the flow is not calculated during bypass, an additional setting is required whenever the unit is in economizer bypass mode.

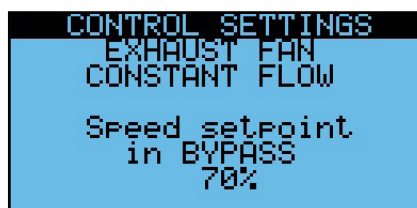

### 5.3.3 Supply Fan Command Tracking Control Option

The controller will adjust the exhaust fan VFD or ECM command to track the supply fan VFD or ECM command.



The minimum (50%) and maximum (200%) tracking rates are adjustable. This exhaust fan operation mode can be used to maintain proportional supply and exhaust fan commands as the supply fan modulates. The minimum % is the lowest speed the exhaust fan will be commanded to avoid fan alarms.

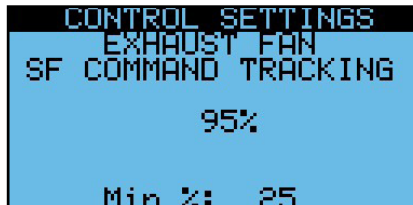

### 5.3.4 Supply Fan Flow Tracking Control Option

The controller will adjust the exhaust fan VFD or ECM command to track the supply fan air flow rate.



The offset from the SA flow rate is adjustable from -25% to +25%. An adjustable PI loop will compare the measured EA flow to the airflow rate setpoint and adjust the fan speed. This exhaust fan operation mode can be used to maintain proportional supply and EA flows as the supply fan modulates and as the unit filters become loaded.



### 5.3.5 Room Static Pressure Control Option

The controller will adjust the exhaust fan VFD or ECM command to maintain the room duct static pressure at a setpoint.



The room static pressure setpoint is entered and adjusted from the unit controller display or provided by the BMS. The minimum and maximum values for the room static pressure setpoint are unit dependent. An adjustable PI loop will compare the measured room static pressure to the static pressure setpoint and adjust the exhaust fan speed. If the measured static pressure varies from the desired static pressure by more than 0.05 inches water gauge (adjustable) for more than 300 seconds (adjustable) a room static pressure alarm will be set to true. This exhaust fan operation mode can be used to provide a constant room pressure for variable exhaust systems.

```

CONTROL SETTINGS
EXHAUST FAN
ROOM STATIC CONTROL
Setpoint 0.050"w9
KP 1.0 Ti 30
Min Command 15.0%
Max Command 100.0%
Start %: 30 Delay120s
    
```

```

ALARM SETTINGS
EF Room Press Tol
110.0%
>100% disables alarm
Pressure Alarm Delay
120 sec
    
```

```

ALARM SETTINGS
EF Room Press Alarms
En Low Press Alm? NO
Alarm Level: 0.0"w9
En High Press Alm NO
Alarm Level: 5.2"w9
Pressure Alarm Delay
120 sec
    
```

### 5.3.6 Exhaust Duct Static Pressure Control Option

The controller will adjust the exhaust fan VFD or ECM command to maintain the exhaust duct static pressure at a setpoint. This option requires a field-installed duct pressure transmitter and setup for the transmitter in the I/O configuration.

```

CONTROL SETTINGS
EXHAUST FAN CONTROL
Duct Static Pressure
    
```

The EA duct static pressure setpoint is entered and adjusted from the unit controller display or provided by the BMS. The minimum and maximum values for EA duct static pressure setpoint are unit dependent. An adjustable PI loop will compare the measured EA duct static pressure to the static pressure setpoint and adjust the fan speed. If the measured static pressure varies from the desired static pressure by more than 0.05" w.g. (adjustable) for more than 60 seconds (adjustable) a EA static pressure alarm will be set to true.

```

CONTROL SETTINGS
EXHAUST FAN
DUCT STATIC CONTROL
Setpoint 0.50"w9
KP 1.0
Ti 30
Start %: 30 Delay120s
Min %: 25
    
```

```

ALARM SETTINGS
EF Duct Press Tol
110.0%
>100% disables alarm
Pressure Alarm Delay
120 sec
    
```

```

ALARM SETTINGS
EF Duct Press Alarms
En Low Press Alm? NO
Alarm Level: 0.0"w9
En High Press Alm NO
Alarm Level: 5.2"w9
Pressure Alarm Delay
120 sec
    
```

## 6.0 TEMPERING CONTROL

### 6.1 MODES OF OPERATION

There are four modes of operation (if applicable):

- Dehumidification (and cooling) Mode —will run the cooling to maintain a dehumidification setpoint (around 50°F) and then reheat the air (to around 60°F), if feature is included
- Heating Mode—Will run the heating to maintain a heating setpoint
- Sensible Cooling Mode—Will run the cooling to maintain a cooling setpoint
- Ventilation Mode—Will only run the fans for ventilation

The mode during occupied operation will depend upon the following conditions. The mode is dependent upon whether the feature is enabled and the lockout dewpoint or outdoor air temperature for that feature

See the following sections for more information on these modes. The mode is determined in this order:

1. Heating: Is the unit configured for heating? Is the outdoor air temperature lower than the heating lockout temperature?
2. Dehumidification: Is the unit configured for dehumidification? If so, is the unit in dehumidification mode?
3. Cooling: Is the unit configured for cooling? Is the outdoor air temperature higher than the cooling lockout temperature?
4. If it in no other mode and the unit is on, it will be in Ventilation Mode.

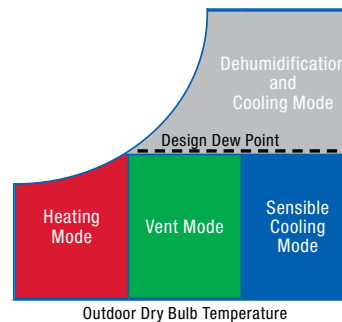

In normal heating operation, the controller will prevent the heater from running when the Outdoor Air temperature is above the Lockout Above setpoint. This causes the unit to use OA air for heating instead of firing the heat module. The Lockout Above setpoint is assigned by the user, based on both ambient temperatures and experience with the building being heated. RenewAire suggests an initial Lockout Above setting of 50°F. If the OA air is at 50°F and the Exhaust Air coming from the Occupied Space is at 72°F, the Supply Air recovers enough heat energy from the Exhaust Air that it will reach about 67.6°F without any supplementary heat from the heat module when the heat exchange core is at maximum efficiency. In every building, there is additional heat being generated by human activity, equipment and thermal gain from sunlight, etc. If there is very little additional heat being generated in the Occupied Space, the Lockout Above setting may have to be raised. If there is a great deal of heat being generated, the Lockout Above setting can actually be lowered further.

The Lockout Above function has a hysteresis band built into it to prevent short-cycling when the OA air is near the Lockout Above setpoint. In other words, if the Lockout Above setpoint is at 50°F, the gas heat module will be disabled whenever the OA air temperature is higher than 50°F. When the OA air temperature drops to 50°F, the controller will continue to lockout the heat module until the OA temperature drops an additional 1.8°F, the hysteresis band.

Lockout Below performs the same function as Lockout Above, but for cooling. The factory setpoint for Lockout Below is 70°F, meaning that if the Outdoor Air temperature is lower than 70°F, the cooling unit will be blocked from running. RenewAire suggests an initial Lockout Below setting of 70°F.

If the controller shuts off the heat command signal because of the Lockout Above setting, the Unit Status > Heating screen will show Disabled, regardless of the strength of the Call For Heat signal.

### 6.2 DEHUMIDIFICATION

The dehumidification is performed with the cooling. Therefore, the unit must have cooling enabled. It may also have HGRH enabled here, used for reheat during dehumidification.

```

UNIT CONFIGURATION
Unit Type: Premium
Bypass Damp: Enable
BP Type: Modulating
BP Seq: INTERNAL
Isolat Damp: Enable
Enable Heat: NO
Enable Cool: NO
    
```

```

UNIT CONFIGURATION
En Mod HGRH: YES
En 2Pos HGRH: NO
If HGRH enabled, go to
I/O Config and set
Dehum changeover mode
and assign LAT sensor
to a free input.
    
```

#### 6.2.1 Dehumidification Mode Settings

The type of dehumidification changeover is set in *I/O Configuration*. It is normally set for return air but if there is a lot of air changes this will cause the cooling to cycle excessively so the setting can be set for changeover based on outdoor air. It can also be disabled here.

```

I/O Configuration
Dehumidification
Changeover Selection
Return Air Value

Choose Outdoor Air for
applications w/19 amts
of Outdoor Air/changes
    
```

```

I/O CONFIGURATION
Dehumidification
Changeover Selection
Dehum Disabled

Choose Outdoor Air for
applications w/19 amts
of Outdoor Air/changes
    
```

The setting for changeover is in Control Variables. Dehumidification mode will be on at the dehumidification setpoint + the hysteresis value set here. It will turn back out of dehumidification mode below the setpoint.

This screen will not show up if dehumidification is disabled in the prior screen.

```

CONTROL SETTINGS
Dehumid Mode On
Based on Return Air
Dewpoint:

On above SP + Hyst
60.0%(SP) 1.7%(hyst)
Off below SP
    
```

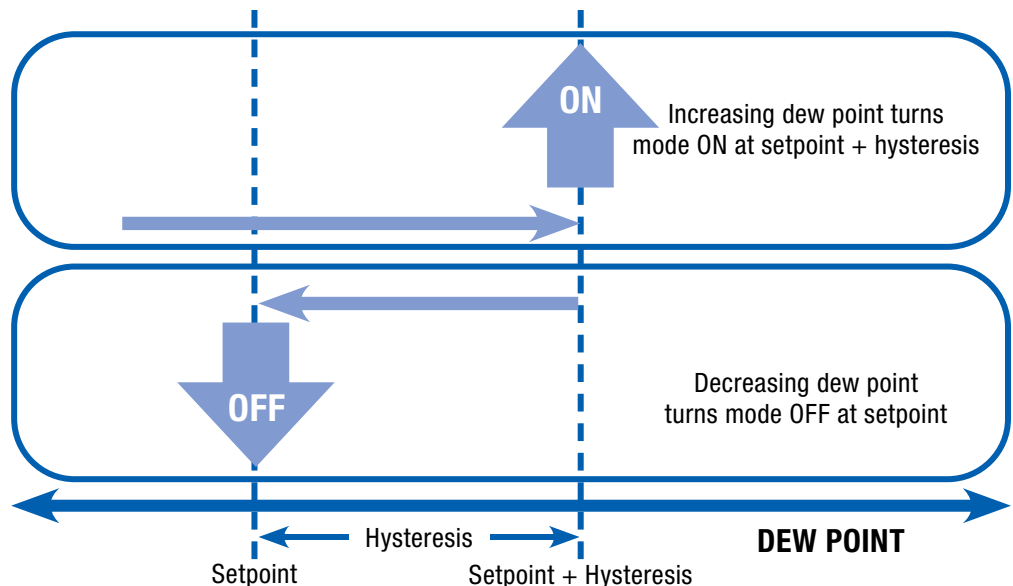

The status can be monitored in *Unit Status*.

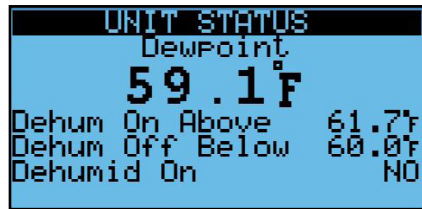

## 6.2.2 Dehumidification Types and Settings

There are four possibilities for dehumidification:

1. Cooling with Hot Gas Reheat. In this case the HGRH will be enabled in the above screen.
2. Cooling with Reheat performed by the heating source.
3. Cooling only. Since this will produce very cold air, this method should not be used to feed the space directly.
4. Disabled. In this case no dehumidification mode is available.

### 6.2.2.1 Dehumidification with Hot Gas Reheat

This dehumidification method requires DX cooling. It relies on an additional HGRH coil downstream of the cooling coil in which the hot refrigerant piping is in contact with the supply air. This allows a portion of the refrigerant cycle's normally rejected heat to be reclaimed as reheat.

When the return (or outdoor) air dew point exceeds the 55 degrees F (adjustable) the dehumidification mode will be enabled. The air is cooled to a cooling coil leaving temperature setpoint, usually 55 F or below. Then it is reheated to a unit supply temperature setpoint (or return air, based on setting for heating), usually around 60 F. An adjustable PI (proportional & integral) loop will compare the measured air temperature to the air temperature setpoint and adjust the analog output to the valve.

If the unit was ordered with HGRH, the coil leaving temperature sensor was included.

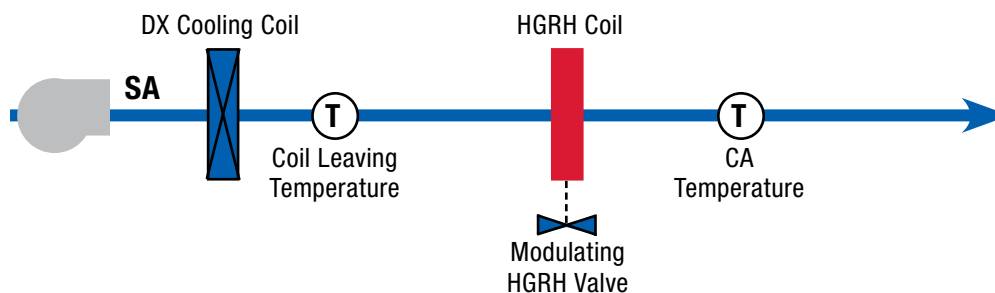

The settings for this method require that

- Cool and HGRH are enabled in the *Unit Configuration*.
- Input assigned to Coil LAT Sensor and LAT Sensor installed after coil.
- A setpoint for the coil leaving temperature and the CA temp are set.
- KP and Ti settings are adjusted for control of the HGRH valve, if necessary.
- The purge settings are adjusted, if necessary. These settings show a low % whereby if the valve is set to the low limit for the low limit time, it will be opened for the high override % for the override time.

```

CONTROL SETTINGS
Dehumidification
Reheat performed with
HGRH:
Cooling Coil LAT 50.0%
CA Reheat SetP 64.4%
    
```

```

CONTROL SETTINGS
HGRH Settings
KP 0.6
Ti 40
Low Continuous 10.0%
Low Time Limit 600s
High Override 50.0%
Override Time 60s
    
```

The status can be viewed in *Unit Status*.

```

UNIT STATUS
Hot Gas Reheat
68.2°F
Setpoint 70.0%
Dehumid On NO
Command 0.0%
Purge NO
    
```

6.2.2.2 Dehumidification with Reheat from Heat Source

This dehumidification method uses any cooling source and heating source.

When the return (or outdoor, selectable) air dew point exceeds the 55°F (adjustable) the dehumidification mode will be enabled. The air is cooled to a cooling coil leaving temperature setpoint, usually 55°F or below. Then it is reheated to a CA temperature setpoint (or RA, based on setting for heating), usually around 60°F. An adjustable PI loop will compare the measured air temperature to the air temperature setpoint and adjust the analog output to the valve. The NO1 heating enable contact is engaged whenever the heating output is at 1% or higher.

To use this method you need to add a cooling coil leaving temperature sensor, P/N 131318, and install it after the cooling method. It should be wired as described in the *Verify Unit Configuration* section.

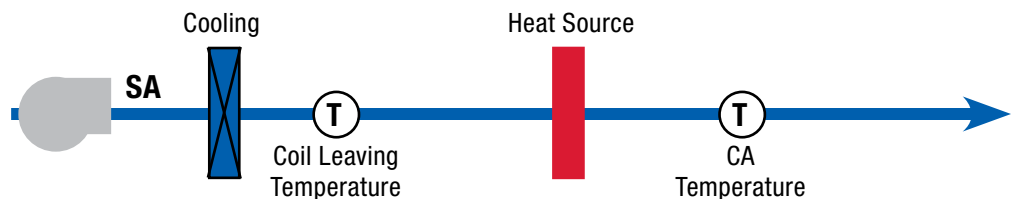

The settings for this method require that

- Cool and Heat are enabled in the *Unit Configuration*
- Input assigned to Coil LAT Sensor and LAT Sensor installed after coil
- Set Allow heat src in dehumid to YES in *I/O Configuration*
- A setpoint for the coil leaving temperature and the CA temp are set

```

I/O CONFIGURATION
Allow reheat from
heat src in dehumid?
YES
Requires add of Coil
Leaving Air Temp
Sensor P/N 131318
    
```

```

CONTROL SETTINGS
Dehumidification
Reheat performed with
heat source:
Cooling Coil LAT 50.0%
CA Reheat SetP 64.4%
    
```

The status can be viewed in *Unit Status*.

```

UNIT STATUS
Dehum Reheat w/Heat
  66.5°F
Setpoint 64.4°F
Dehumid On NO
    
```

6.2.2.3 Dehumidification with No Reheat

This dehumidification method uses any cooling source.

When the return (or outdoor) air dew point exceeds the 55°F (adjustable) the dehumidification mode will be enabled. The air is cooled to a CA temperature setpoint, usually around 50–55°F. If feeding the space directly, this could cause overcooling.



The settings for this method require that

- Cool is enabled in the *Unit Configuration*
- Set Allow heat src in dehumid to No in *I/O Configuration*
- A setpoint for the CA temp is set

```

I/O CONFIGURATION
Allow reheat from
heat src in dehumid?
      NO

Requires add of Coil
Leaving Air Temp
Sensor P/N 131318
    
```

```

CONTROL SETTINGS
Dehumidification
CA Temp SP
for Dehum:      50.0°F
    
```

6.2.2.4 Dehumidification Disabled

The settings for this method require that

- Dehumidification Changeover Selection is set to “Dehum Disabled” in *I/O Configuration*. In this case the cooling will only be used to supply sensible cooling.

**6.3 HEATING**

The heating requires that heating be enabled in the *Unit Configuration*. The heating type is set in *Unit Configuration* or *Control Settings*.

```

UNIT CONFIGURATION
Unit Type: Premium
Bypass Damp: Disable
BP Type: Two-Position
BP Seq: INTERNAL
Isolat Damp: Enable
Enable Heat: NO
Enable Cool: NO
    
```

6.3.1 Heating Mode

For any type of heating there is an outdoor air lockout temperature above which heating will not be allowed. Note that the default is low. This is to ensure that at start up, you can start your fans without worrying if the tempering will also start. This value will need to be raised to an acceptable value.

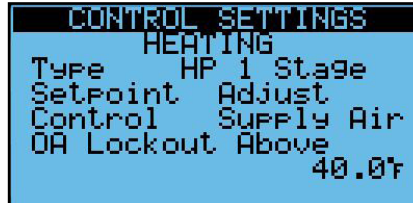

6.3.2 Setpoint Type and Control Type

For each type of heating, you can choose a setpoint type and a control type. Setpoint types available:

- Adjust: If you choose this it will allow you to set a heating setpoint.
- OA Reset: You are prompted to set a reset schedule. In the screen shown, the setpoint will be 70°F if the outdoor air is 0°F or below, and 60°F if the outdoor air is 50°F and above. It will be linear between. For example, if the outdoor air is 25°F, the setpoint will be 65°F. This method is useful to avoid overheating the space or to avoid excess cycling in warmer temperatures.

Control types available:

- CA: Be sure to install your CA temperature sensor far enough down the duct to prevent over-cycling.
- RA: If you are only feeding one space this is a useful control method. RA is always used for unoccupied operation. RA should also be used when a staged heat source is utilized.

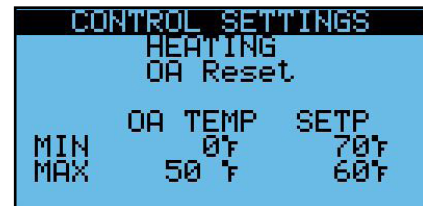

6.3.3 Heating Types

The following heating types are supported:

- 0–10VDC: Gas
- 0–10VDC: Electric
- 10–0VDC: Hot Water Valve
- Single Stage Heater
- Two-Stage Heater
- HP 1 Stage: with or without 0–10VDC aux heat—See *Combined Tempering*
- HP 2 Stage: with or without 0–10VDC aux heat—See *Combined Tempering*
- Dual Temp Coil: A coil that is used for both hot and cold water, depending upon season—See *Combined Tempering*
- VRF—See *Combined Tempering*

The heating type is set at the top of this screen.

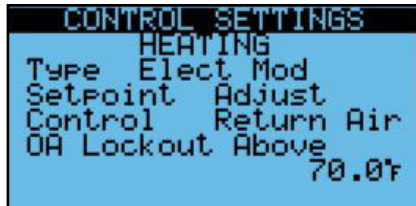

6.3.3.1 0–10VDC Gas or Electric Heating

The mode is determined by the outdoor temperature and the heating lockout temperature settings.

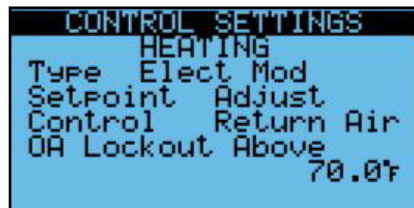

This type of heating will modulate gas or electric heat using PI control. The KP and Ti can be adjusted to fine tune the control. The setpoint is also set here if set for Adjust. The NO1 heating enable contact is engaged whenever the heating output is at 1% or higher.

A unit-specific electrical schematic is found inside the access door to the core module.

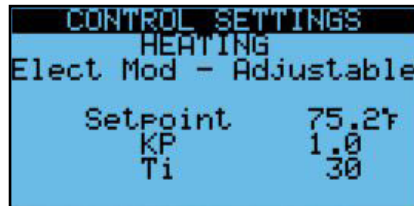

The heating status can be monitored in the *Unit Status*. The screen shows:

- Heating Control Variable which will be as selected if in occupied operation
- Heating setpoint which will be:
  - Heating setpoint if selected adjust
  - Calculated OA reset heating setpoint if selected OA reset
- Whether heating enable 1 is ON
- Command (0–100%) to Heater, where 0 = 0VDC output and 100% = 10VDC output
- Heating Status

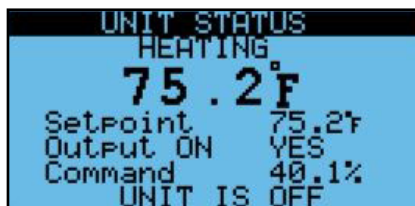



The heating status values are shown. Multiple values may be true.

MESSAGE	MEANING
Heat Locked Out by OA	The heating outdoor air lockout is higher than the OA temperature.
Unit OFF	Unit is off.

6.3.3.2 10–0VDC Hot Water Valve

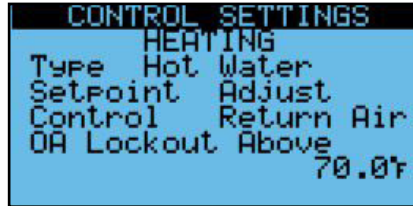
The mode is determined by the outdoor temperature and the heating lockout temperature settings.



 **NOTE:** The valve control can be set directly from the BMS if you change Valve control to BMS. In this case all Heating Control settings from the controller will be ignored.

The hot water valve control is 10VDC for closed and 0VDC for open so that it fails open. This type of heating will modulate using PI control. The KP and Ti can be adjusted to fine tune the control. The setpoint is also set here if set for Adjust. The NO1 heating enable contact is engaged whenever the heating output is at 99% or lower.

By default the valve is scaled 0–10 VDC but it can be changed to 2-10 VDC in the *I/O Configuration*.

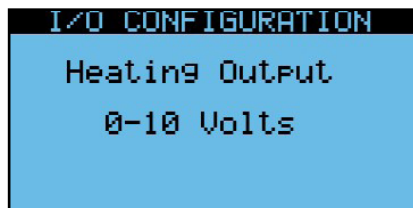

The heating status can be monitored in the *Unit Status*. The screen shows:

- Heating Control Variable which will be as selected if in occupied operation
- Heating setpoint which will be:
  - Heating setpoint if selected adjust
  - Calculated OA reset heating setpoint if selected OA reset
- Whether heating enable 1 is ON
- Command (0–100%) to Heater, where 0 = 10VDC output and 100% = 0VDC.
- Heating Status



The heating status values are shown. Multiple values may be true.

MESSAGE	MEANING
Heat Locked Out by OA	The heating OA lockout is higher than the OA temperature.
Unit OFF	Unit is off.

6.3.3.3 Single Stage Heater

The mode is determined by the outdoor temperature and the heating lockout temperature settings.

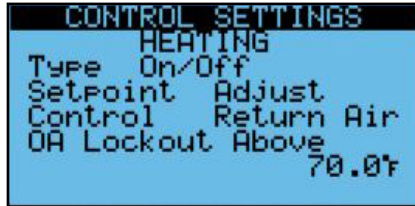

This type of heating cycles one stage of heating to maintain the heating setpoint. You must set a hysteresis value whereby the stage will turn on at the setpoint + hysteresis and turn at setpoint.

The “Use Cool Outs” setting should be set to no for heater mode, where the output used for this control will be the heating output NO1 on the expansion module.

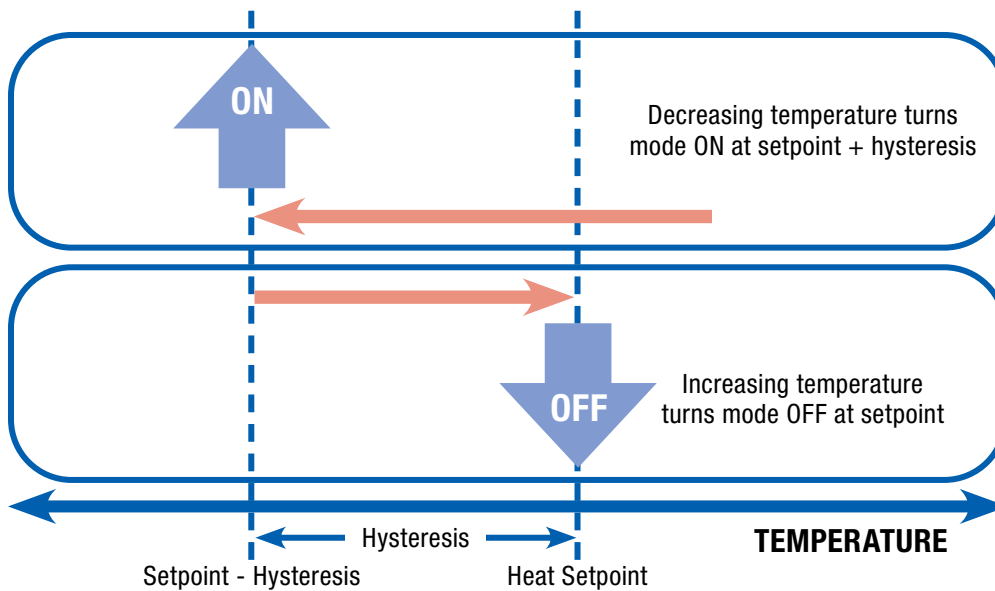
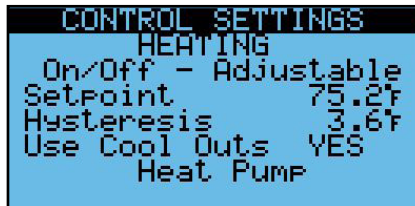

- The heating status can be monitored in the *Unit Status*. The screen shows:
- Heating Control Variable which will be as selected if in occupied operation
  - Heating setpoint which will be:
    - Heating setpoint if selected adjust
    - Calculated OA reset heating setpoint if selected OA reset
  - Whether heating enable 1 is ON
  - Heating Status

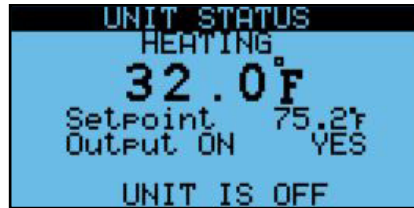

The heating status values are shown. Multiple values may be true.

MESSAGE	MEANING
Heat Locked Out by OA	The heating OA lockout is higher than the OA temperature.
Unit OFF	Unit is off.

6.3.3.4 Two-Stage Heater

The mode is determined by the outdoor temperature and the heating lockout temperature settings.

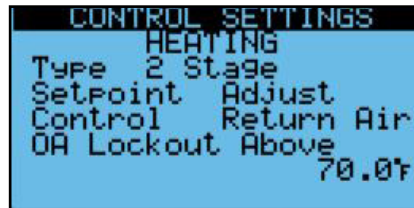

This type of heating cycles two stages of heating to maintain the heating setpoint. You must set a prop band value. This value represents 100%; the wider the prop band the slower the response. Then you specify the “on point” for stages one and two in percentages. Stage one will turn off at setpoint and stage two will turn off at the on point for stage one. There is also a minimum on and off time to prevent over-cycling.

The “Use Cool Outs” setting should be set to no for heater mode, where the output used for this control will be the heating output NO1 on the expansion module.



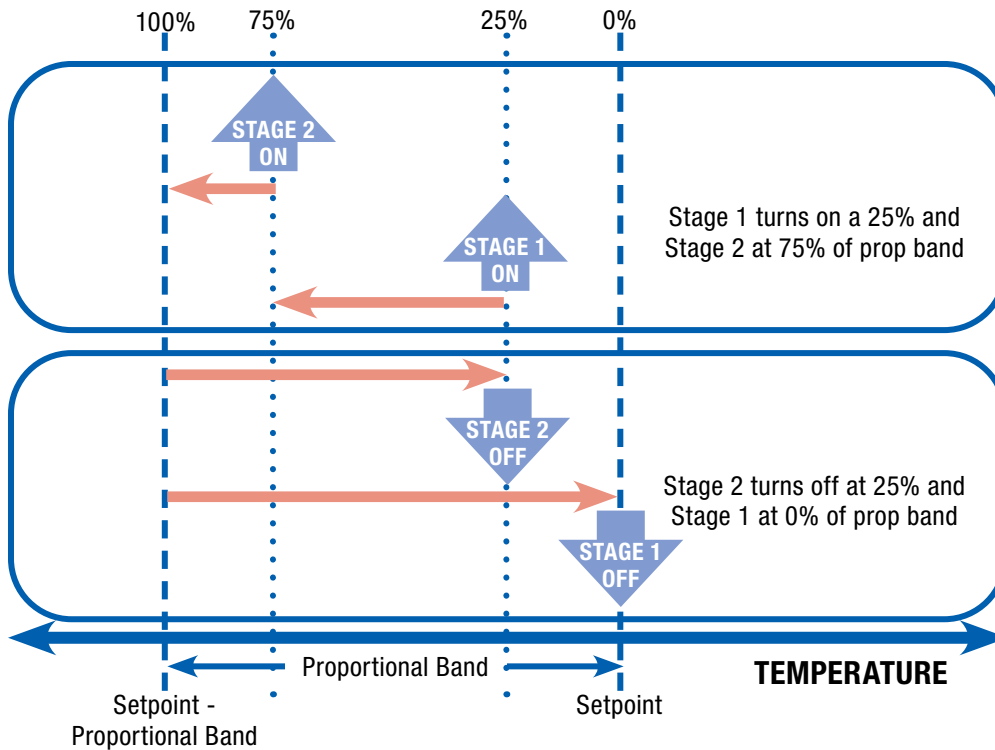

**Example:** In this case  $4^{\circ}\text{F} = 100\%$  which means that  $1^{\circ}\text{F} = 25\%$ , which makes our calculation easy. With the default settings, stage 1 turns on at  $75.2 - 1 = 74.2$ . Stage 2 turns on at  $75.2 - 3 = 72.2$ .

- The heating status can be monitored in the *Unit Status*. The screen shows:
- Heating Control Variable which will be as selected if in occupied operation
  - Heating setpoint which will be:
    - Heating setpoint if selected adjust
    - Calculated OA reset heating setpoint if selected OA reset
  - Whether heating enable 1 is ON
  - Heating Status



The heating status values are shown. Multiple values may be true.

MESSAGE	MEANING
Heat Locked Out by OA	The heating OA lockout is higher than the OA temperature.
Unit OFF	Unit is off.

### 6.4 COOLING

The cooling requires that cooling be enabled in the *Unit Configuration*. The cooling type is set in the *Control Settings*. The unit should also be set to Premium, as shown at the top of the screen.



#### 6.4.1 Cooling Mode

For any type of cooling there is an outdoor air lockout temperature below which cooling will not be allowed. Note that the default is high. This is to ensure that at start up, you can start your fans without worrying if the tempering will also start. This value will need to be lowered to an acceptable value.

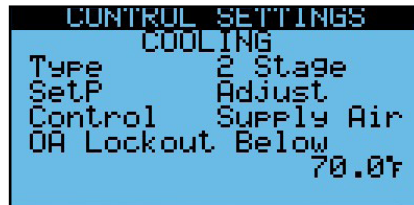

#### 6.4.2 SetP

Can be set to Adjustable or RA Reset which will allow you to change the setpoint of supply air based on return air.

#### 6.4.3 Cooling Control Type

For each type of cooling, you can choose a control type.

Control types available:

- CA: Be sure to install your CA temperature sensor far enough down the duct to prevent over-cycling
- RA: If you are only feeding one space this is a useful control method.

#### 6.4.4 Cooling Types

The following cooling types are supported:

- On/Off: one-stage DX or heat pump—See *Combined Tempering* for heat pump operation
- 2 stage: two-stage DX or heat pump—See *Combined Tempering* for heat pump operation
- CW Mod: 0–10VDC signal to a chilled water valve, also used in Dual Temp Coil—See *Combined Tempering*.
- VRF—See *Combined Tempering*
- Modulating Bypass

The cooling type is set at the top of this screen.

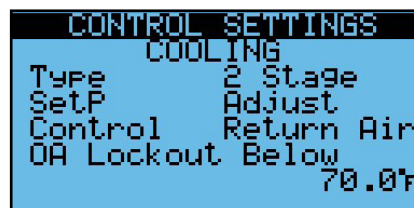

6.4.4.1 On/Off: One Stage of Cooling

If this is a one-stage heat pump, see *Combined Tempering*.

The mode is determined by the outdoor temperature and the cooling lockout temperature settings.

```

CONTROL SETTINGS
COOLING
Type      On/Off
SetP      Adjust
Control    Return Air
OA Lockout Below
              70.0°F
    
```

This type of cooling cycles one stage of cooling to maintain the cooling setpoint. You must set a hysteresis value whereby the stage will turn on at the setpoint + hysteresis and turn at setpoint. There is also a minimum on and off time to prevent over-cycling.

```

CONTROL SETTINGS
COOLING - Single Stage
Adjustable Setpoint
Setpoint    75.2°F
Hysteresis  3.6°F
Min ON Time 300s
Min Off Time 300s
    
```

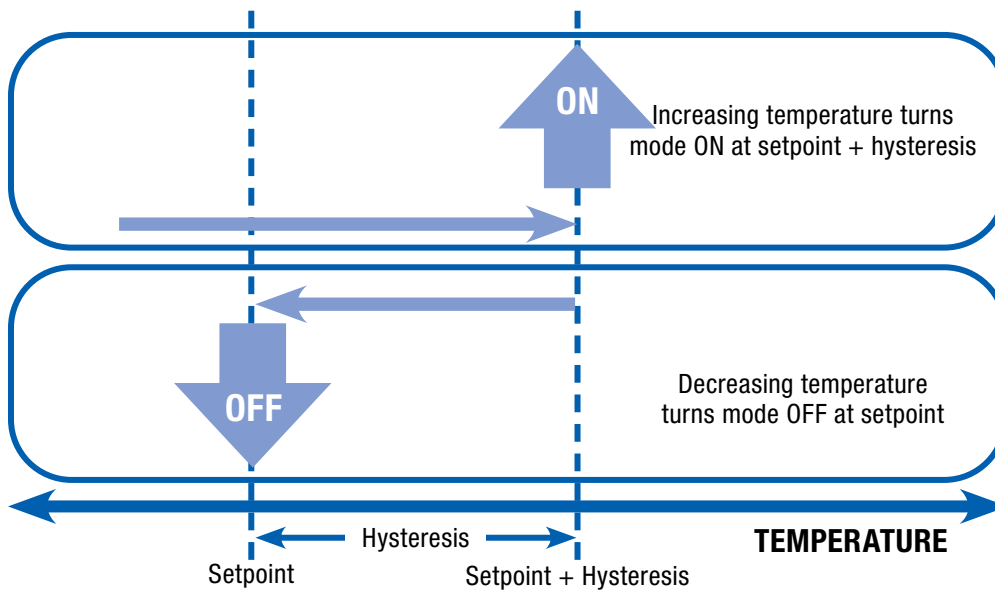

The cooling status can be monitored in the *Unit Status*. The screen shows:

- Cooling Control Variable which will be supply or return air, as selected.
- Cooling setpoint
- Whether cooling enable 1 is ON
- Cooling Status

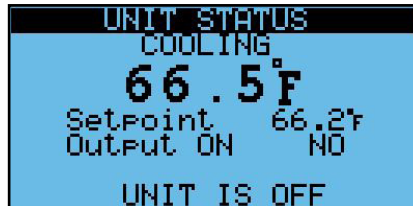

The cooling status values are shown. Multiple values may be true.

MESSAGE	MEANING
Cool Locked Out by OA	The cooling OA lockout is lower than the OA temperature.
Lockout Overlap	The OA lockouts for heating and cooling overlap. (No vent mode). The heating takes preference.
Econ Only	If cooling is not on
Econ Mode	If in economizer mode.
Unit OFF	Unit is off.

6.4.4.2 2-Stage: Two Stages of Cooling

If this is a two-stage heat pump, see *Combined Tempering*.

The mode is determined by the outdoor temperature and the cooling lockout temperature settings.

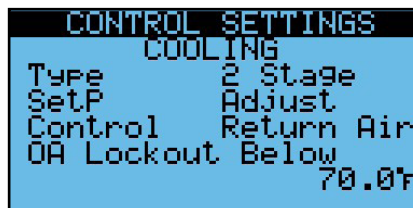

This type of cooling turns cycles two stages of cooling to maintain the cooling setpoint. You must set a prop band value. This value represents 100%; the wider the prop band the slower the response. Then you specify the “on point” for stages one and two in percentages. Stage one will turn off at setpoint and stage two will turn off at the on point for stage one. There is also a minimum on and off time to prevent over-cycling.



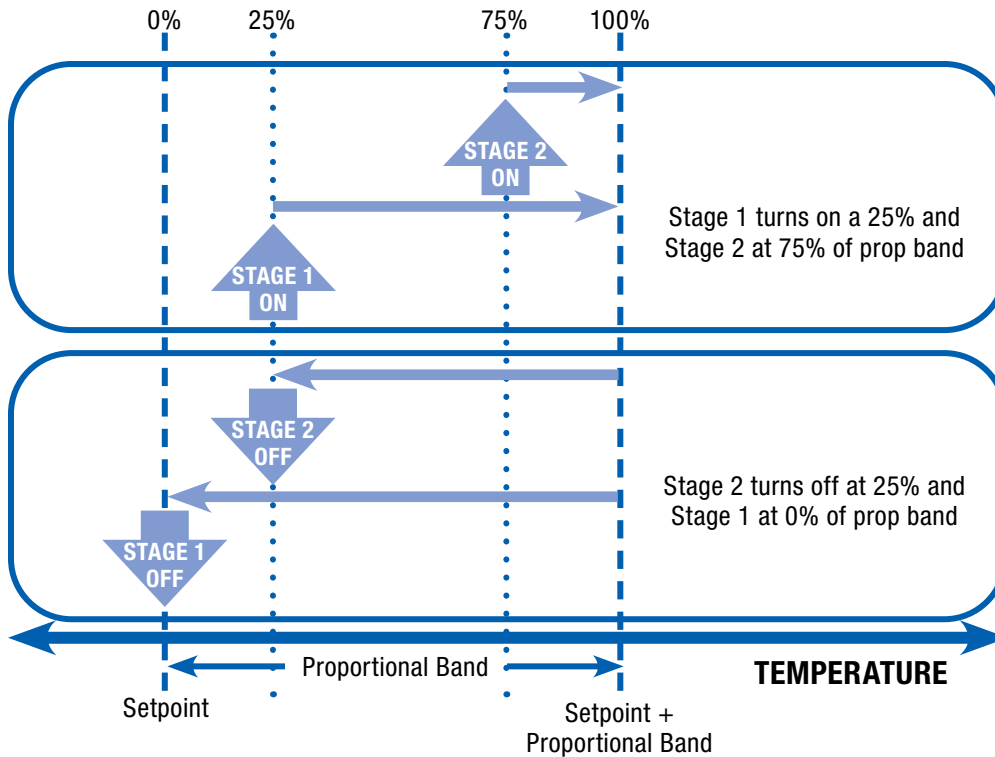

**Example:** In this case 4°F = 100% which means that 1°F = 25%, which makes our calculation easy. With the default settings, stage 1 turns on at 66.2 + 1 = 63.2. Stage 2 turns on at 66.2 + 3 = 65.2.

The cooling status can be monitored in the *Unit Status*. The screen shows:

- Cooling Control Variable which will be supply or return air, as selected
- Cooling setpoint
- Whether cooling enable 1 (stage 1) and cooling enable 2 (stage 2) are ON
- Cooling demand, expressed as a percentage of proportional band
- Cooling Status

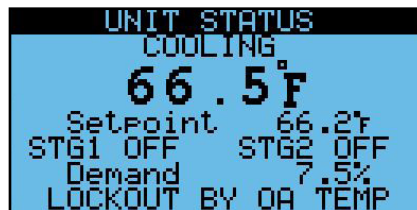

The cooling status values are shown. Multiple values may be true.

MESSAGE	MEANING
Cool Locked Out by OA	The cooling OA lockout is lower than the OA temperature.
Lockout Overlap	The OA lockouts for heating and cooling overlap. (No vent mode). The heating takes preference.
Econ Only	If economizer is open less than 100%.
Econ Mode	If in economizer mode.
Unit OFF	Unit is off.

6.4.4.3 CW Mod: Chilled Water Modulating Coil

If this is a dual temp coil used for heating and cooling, see *Combined Tempering*.

The mode is determined by the outdoor temperature and the cooling lockout temperature settings.

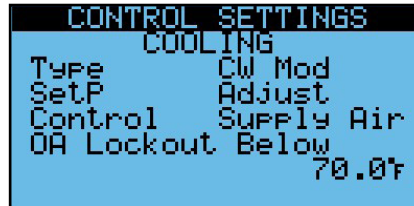

This type of cooling modulates a 0–10VDC chilled water valve using PI control. The KP and TI can be adjusted to fine tune the control. The NO4 cooling enable contact is engaged whenever the cooling output is at 1% or higher.

By default the valve is scaled 0-10 VDC but it can be changed to 2–10 VDC in the *I/O Configuration*.

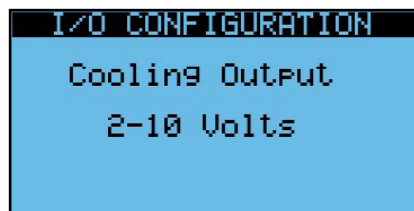

The cooling status can be monitored in the *Unit Status*. The screen shows:

- Cooling Control Variable which will be supply or return air, as selected
- Cooling setpoint
- Whether cooling enable 1 ON
- Command (0–100%) to valve, where 0 = 10VDC output and 100% = 0VDC.
- Cooling Status



The cooling status values are shown. Multiple values may be true.

MESSAGE	MEANING
Cool Locked Out by OA	The cooling OA lockout is lower than the OA temperature.
Lockout Overlap	The OA lockouts for heating and cooling overlap. (No vent mode). The heating takes preference.
Econ Only	If economizer is open less than 100%.
Econ Mode	If in economizer mode.
Unit OFF	Unit is off.

6.4.4.4 Cooling with Modulating Bypass

If the unit has no cooling method, units with modulating bypass such as the DN will allow you to use the economizer to maintain a cooling setpoint rather than just all or nothing for bypass. The bypass setting from the economizer function are followed, and when enabled, the damper will modulate to maintain setpoint.

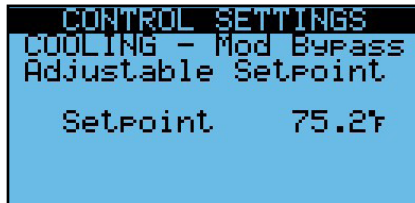

6.5 COMBINED TEMPERING

Combined Tempering are methods where the same control is used for heating and cooling. These types include:

- Single-stage heat pump with or without auxiliary heat
- Two-stage heat pump with or without auxiliary heat
- VRF with or without auxiliary heat
- Dual Temp water coil which supplies heating or cooling, depending upon season

These methods require that both heating and cooling be enabled in the *Unit Configuration*.

6.5.1 Heat Pump 1-Stage: with or without 0–10VDC Aux Heat

This type requires cooling type On/Off and heating type On/Off. These type settings are made in the *Control Settings*.

6.5.1.1 Heat Pump 1-Stage Mode

The mode is determined by the outdoor temperature and the heating and cooling lockout temperature settings.

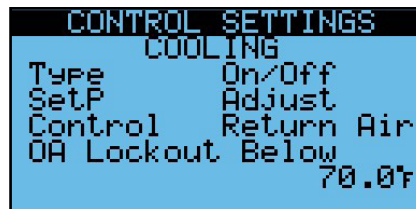
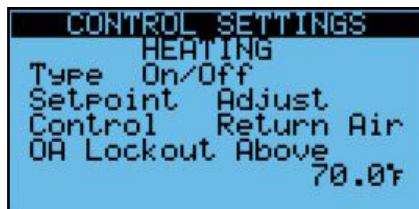

6.5.1.2 Heat Pump 1-Stage Cooling Operation

This type of cooling cycles one stage of cooling to maintain the cooling setpoint. You must set a hysteresis value whereby the stage will turn on at the setpoint + hysteresis and turn at setpoint. There is also a minimum on and off time to prevent over-cycling.

If in cooling mode, and the unit calls for cooling, it puts the tempering mode output used for a reversing valve, in the cool position and after a delay, will turn the compressor on and off to maintain the cooling setpoint.

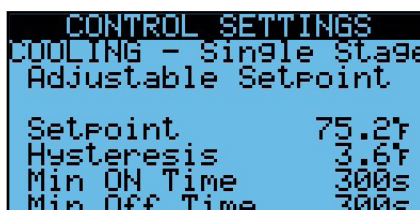

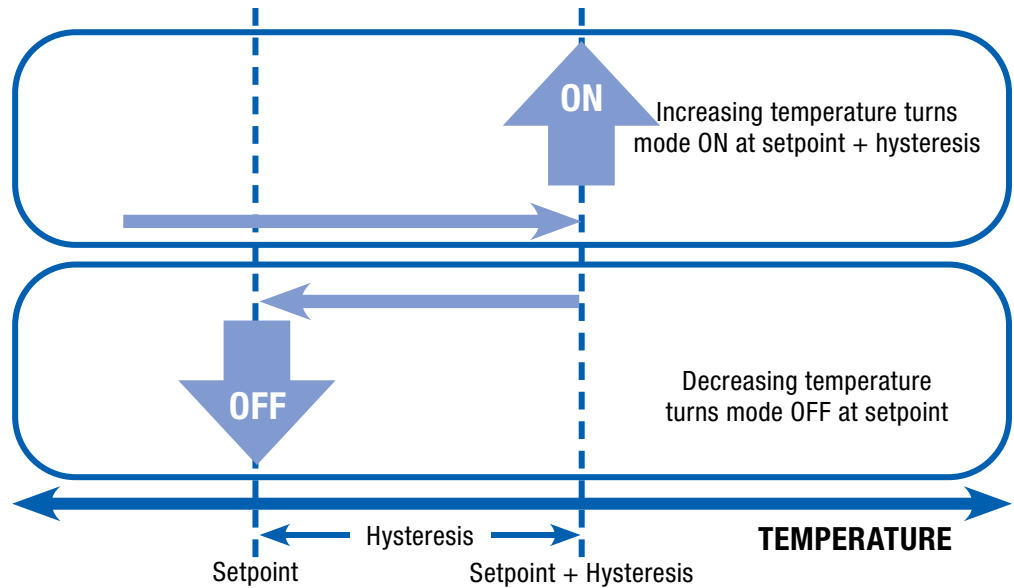

6.5.1.3 Heat Pump 1 Stage Heating Operation

This type of heating cycles one stage of compressor to maintain the heating setpoint while the reversing valve is in heat mode. There is also an option to use axillary heat when the OA is below a certain temperature. You must set a hysteresis value whereby the stage will turn on at the setpoint + hysteresis and turn at setpoint. There is also a minimum on and off time to prevent over-cycling.

If in heating mode, and the unit calls for heating, it puts the tempering mode output used for a reversing valve, in the heat position and after a delay, will turn the compressor on and off to maintain the heating setpoint.

```

CONTROL SETTINGS
HEATING
On/Off - Adjustable
Setpoint      75.2F
Hysteresis    3.6F
Use Cool Outs YES
Heat Pump
    
```

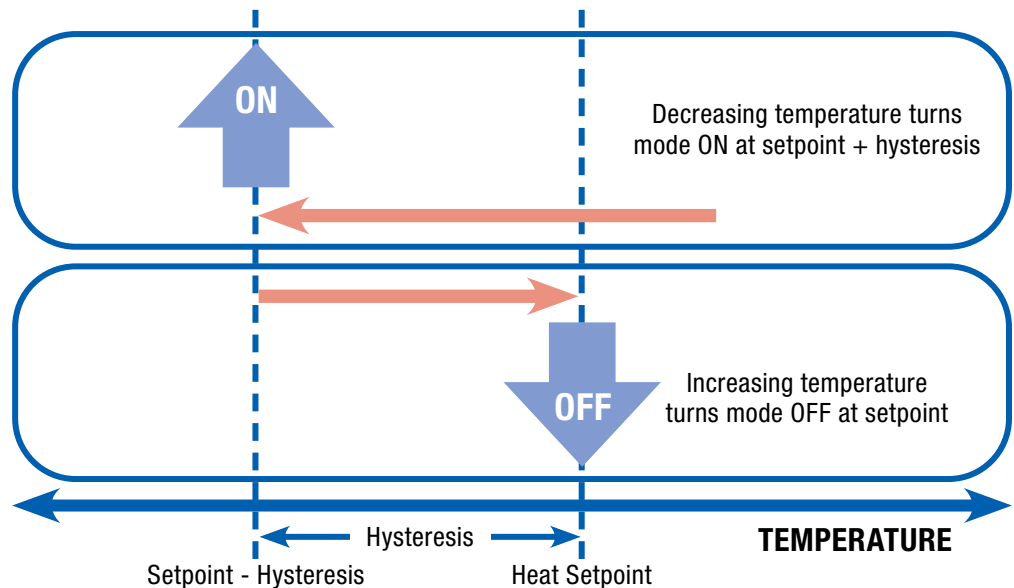

6.5.1.4 Heat Pump 1-Stage Auxiliary Heat

The unit allows you to use an 0–10VDC auxiliary heat source when the outdoor temperature is very cold. It will run a PI control to maintain the heat setpoint with the aux heat instead of the heat pump. If you have an auxiliary 0–10VDC heat source:

- Set the *Aux Heating?* To YES
- Set the outdoor temperature at which the unit will change from using the heat pump to aux heat.
- Adjust the KP and Ti for the PI loop, if necessary.

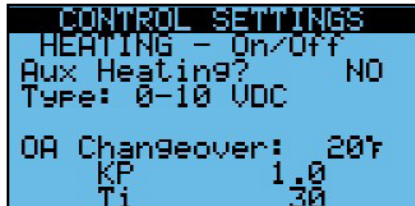

6.5.1.5 Heat Pump 1-Stage Reversing Valve

The reversing valve controls which direction the refrigerant flows. On change of mode (i.e. cool to heat), there will be a delay before the compressor turns on to allow the valve to come into position.

Reversing valve settings:

- Delay: This is the delay between the heating and cooling changeover where the compressor will not be turned on to allow the valve to get into position.
- Contact Open: Choose to have the contact open in heat or cool.



6.5.1.6 Heat Pump 1 Stage System Monitoring

The heat pump is monitored with heating and cooling screens as well as a reversing valve screen and if auxiliary heat is enabled, a screen showing its status.

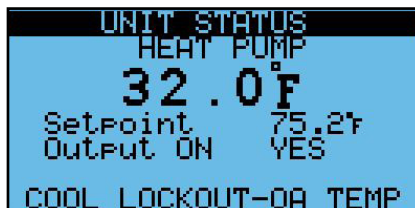

The heat pump status values are shown. Multiple values may be true.

MESSAGE	MEANING
Cool Locked Out by OA	The cooling OA lockout is lower than the OA temperature.
Heat Locked out by OA	The heating OA lockout is higher than the OA temperature.
Lockout Overlap	The OA lockouts for heating and cooling overlap. (No vent mode). The heating takes preference.
Econ Only	If cooling is not on.
Econ Mode	If in economizer mode.
Unit OFF	Unit is off.
Aux Heat Mode	OA temp is cold enough that the auxiliary heat is used.
IN HEAT MODE	Valve is positioned for heat mode.
IN COOL MODE	Valve is positioned for cool mode.
Valve Positioning	Reversing valve is positioning. Not heat or cool is on during this time.

6.5.2 Heat Pump 2-Stage: with or without 0–10VDC Aux Heat

This type requires cooling type 2-stage and heating type HP 2-Stage.

6.5.2.1 Heat Pump 2-Stage Mode

The mode is determined by the outdoor temperature and the heating and cooling lockout temperature settings.

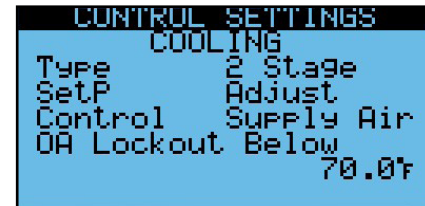
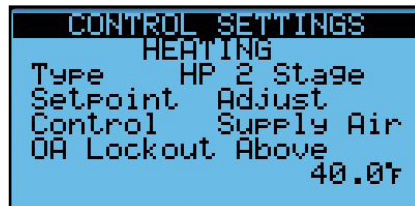

6.5.2.2 Heat Pump 2-Stage Cooling Operation

This type of cooling cycles two stages of cooling to maintain the cooling setpoint. You must set a prop band value. This value represents 100%; the wider the prop band the slower the response. Then you specify the “on point” for stages one and two in percentages. Stage one will turn off at setpoint and stage two will turn off at the on point for stage one. There is also a minimum on and off time to prevent over-cycling.

If in cooling mode, and the unit calls for cooling, it puts the tempering mode output used for a reversing valve, in the cool position and after a delay, will turn the compressor on and off to maintain the cooling setpoint.



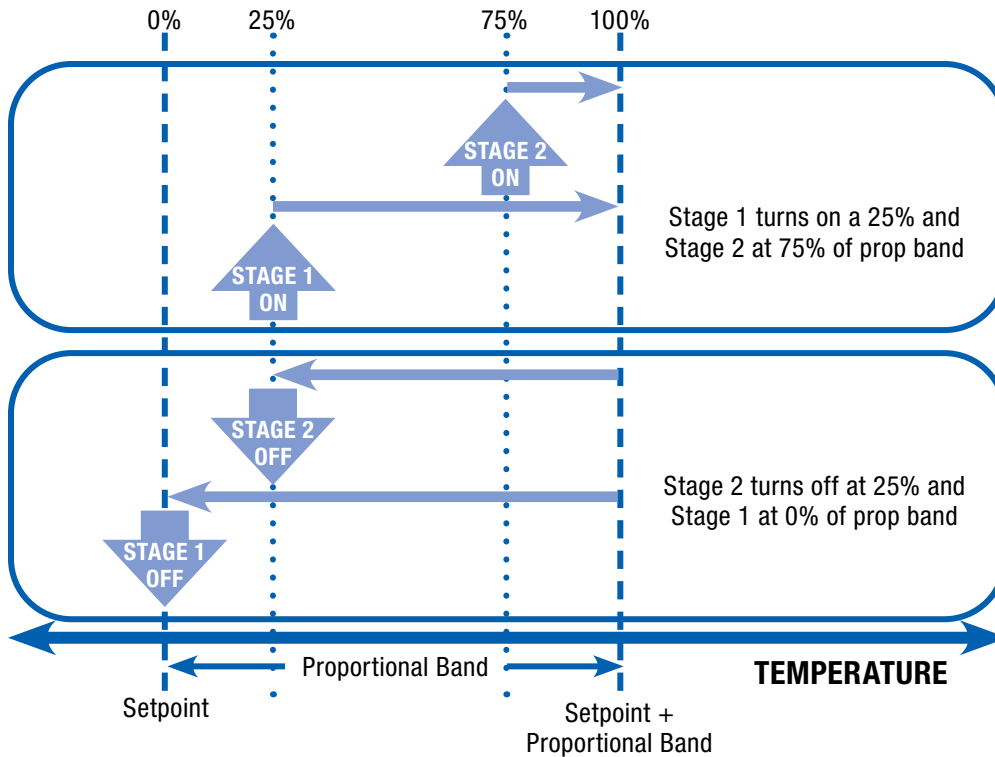

**Example:** In this case 4°F = 100% which means that 1°F = 25%, which makes our calculation easy. With the default settings, stage 1 turns on at 66.2 + 1 = 63.2. Stage 2 turns on at 66.2 + 3 = 65.2.

### 6.5.2.3 Heat Pump 2-Stage Heating Operation

This type of cooling cycles two stages of heating to maintain the heating setpoint. You must set a prop band value. This value represents 100%; the wider the prop band the slower the response. Then you specify the “on point” for stages one and two in percentages. Stage one will turn off at setpoint and stage two will turn off at the on point for stage one. There is also a minimum on and off time to prevent over-cycling.

If in heating mode, and the unit calls for heating, it puts the tempering mode output used for a reversing valve, in the heat position and after a delay, will turn the compressors on and off to maintain the heating setpoint.

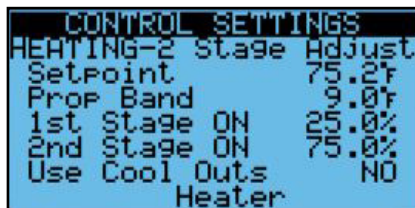

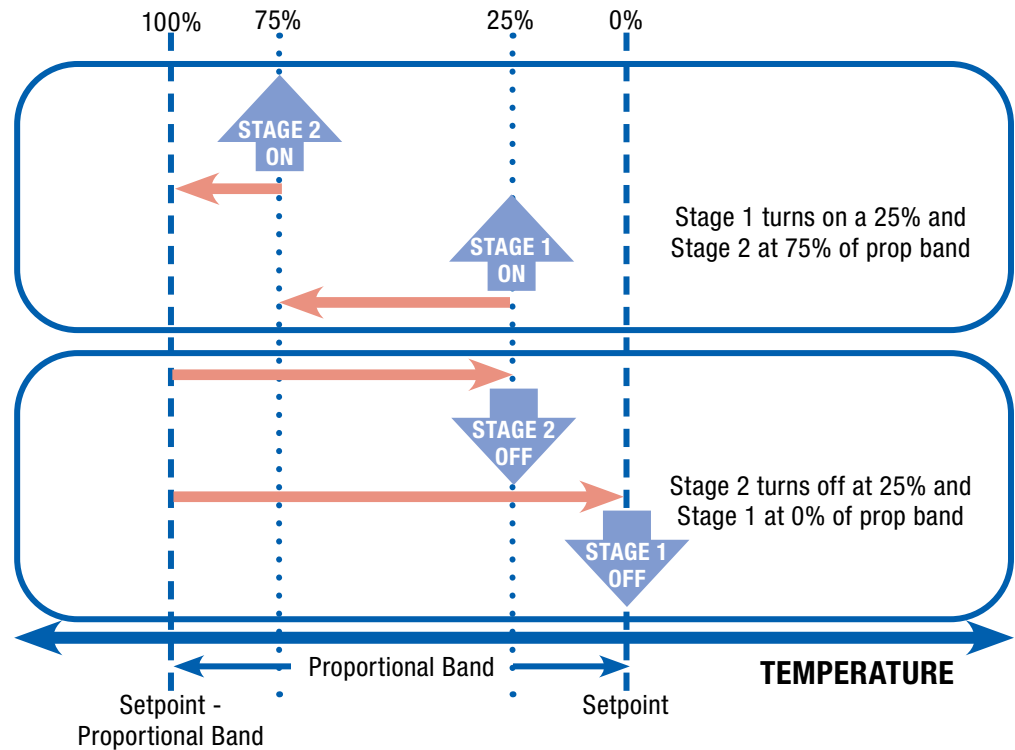

**Example:** In this case 4°F = 100% which means that 1°F = 25%, which makes our calculation easy. With the default settings, stage 1 turns on at 75.2 - 1 = 74.2. Stage 2 turns on at 75.2 - 3 = 72.2.

6.5.2.4 Heat Pump 2-Stage Auxiliary Heat

The unit allows you to use a 0–10VDC auxiliary heat source when the outdoor temperature is very cold. It will run a PI control to maintain the heat setpoint with the aux heat instead of the heat pump. If you have an auxiliary 0–10VDC heat source:

- Set the *Aux Heating?* To YES
- Set the outdoor temperature at which the unit will change from using the heat pump to aux heat
- Adjust the KP and Ti for the PI loop, if necessary.

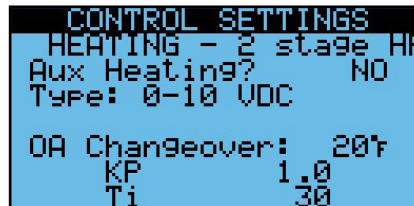

6.5.2.5 Heat Pump 2-Stage Reversing Valve

The reversing valve controls which direction the refrigerant flows. On change of mode (i.e. cool to heat), there will be a delay before the compressor turns on to allow the valve to come into position.

Reversing valve settings:

- Delay: This is the delay between the heating and cooling changeover where the compressor will not be turned on to allow the valve to get into position.
- Contact Open: Choose to have the contact open in heat or cool.

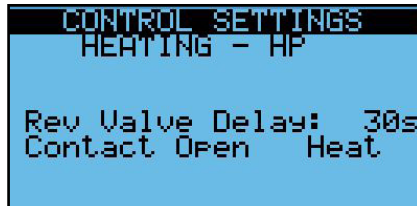

6.5.2.6 Heat Pump 2-Stage System Monitoring

The heat pump is monitored with heating and cooling screens as well as a reversing valve screen and if auxiliary heat is enabled, a screen showing its status.

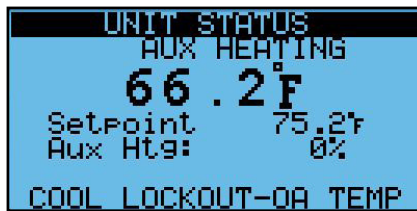
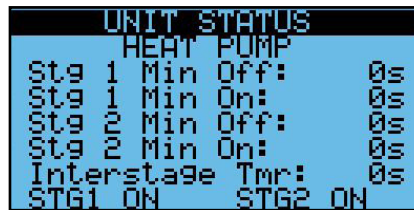
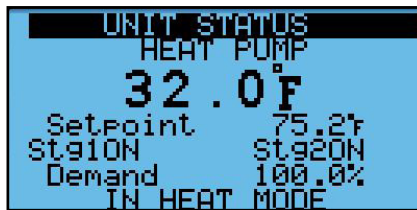

The heat pump status values are shown. Multiple values may be true.

MESSAGE	MEANING
Cool Locked Out by OA	The cooling OA lockout is lower than the OA temperature.
Heat Locked out by OA	The heating OA lockout is higher than the OA temperature.
Lockout Overlap	The OA lockouts for heating and cooling overlap. (No vent mode). The heating takes preference.
Econ Only	If cooling is not on.
Econ Mode	If in economizer mode.
Unit OFF	Unit is off.
Aux Heat Mode	OA temp is cold enough that the auxiliary heat is used.
IN HEAT MODE	Valve is positioned for heat mode.
IN COOL MODE	Valve is positioned for cool mode.
Valve Positioning	Reversing valve is positioning. Not heat or cool is on during this time.

6.5.3 VRF

This type requires cooling type VRF and heating type VRF

6.5.3.1 VRF Mode

The mode is determined by the outdoor temperature and the heating and cooling lockout temperature settings.

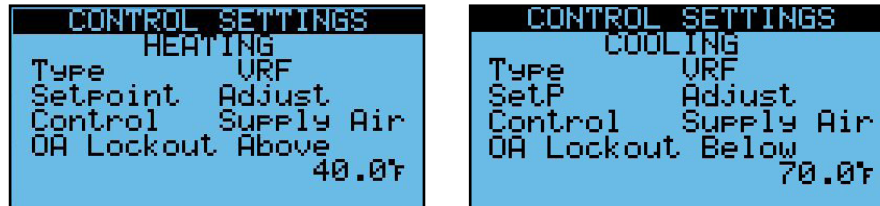

Based on whether the unit is in heating or cooling mode, the controller will set the tempering mode output in the correct position according to this setting. The minimum and maximum values are also set here, as well as whether the cooling minimum demand coincides with the analog minimum or maximum.



6.5.3.2 VRF Cooling Operation

This type of cooling modulates a 0–10VDC output using PI control to maintain the cooling setpoint. The KP and Ti can be adjusted to fine tune the control. The NO4 cooling enable contact is engaged whenever the cooling demand is at 1% or higher.

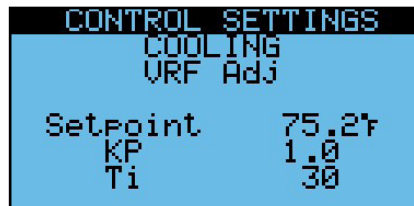

6.5.3.3 VRF Heating Operation

This type of heating modulates a 0–10VDC output using PI control to maintain the heating setpoint. The KP and Ti can be adjusted to fine tune the control. The NO4 cooling enable contact is engaged whenever the heating demand is at 1% or higher.

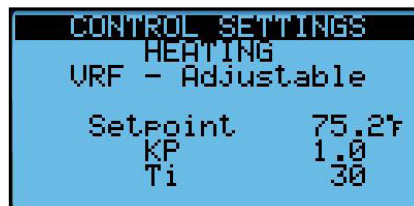

### 6.5.3.4 VRF Monitoring

This screen is available for monitoring the system in *Unit Status*.

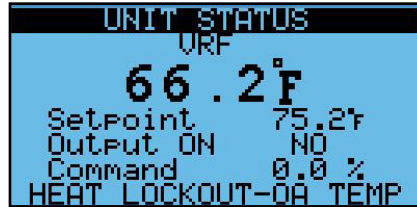

The VRF status values are shown. Multiple values may be true.

MESSAGE	MEANING
Cool Locked Out by OA	The cooling OA lockout is lower than the OA temperature.
Heat Locked out by OA	The heating OA lockout is higher than the OA temperature.
Lockout Overlap	The OA lockouts for heating and cooling overlap. (No vent mode.) The heating takes preference.
Econ Only	If cooling is not on
Econ Mode	If in economizer mode.
Unit OFF	Unit is off.
Aux Heat Mode	Auxiliary Heat is used.
VRF On	VRF is used (rather than aux heat).
IN HEAT MODE	Valve is positioned for heat mode.
IN COOL MODE	Valve is positioned for cool mode.

### 6.5.4 Dual Temperature Coil

The dual temperature coil is a coil which provides heating in the winter and cooling in the summer by changing the temperature of the fluid in the coil. To do this, the coil needs to know what type of fluid (hot or cold) is being provided. It will lock out cooling in heat mode and vice versa. One method for this is a BMS command. The system must be equipped with a BMS system for this control.

The BACnet objects for this are:

- BV 60 BMS\_SetHeatCool: 0 = No, 1 = Yes. This enables the control. This can also be set in the screen below.
- BV 61 BMS\_HeatCoolMode: 0 = Heat, 1 = Cool. This sets the type. The current setting can be seen in the screen below for troubleshooting.

The Modbus Registers for this are:

- Coil 4 BMS\_SetHeatCool: 0 = No, 1 = Yes. This enables the control. This can also be set in the screen below.
- Coil 5 BMS\_HeatCoolMode: 0 = Heat, 1 = Cool. This sets the type. The current setting can be seen in the screen below for troubleshooting.

A second method to tell whether the unit is in hot water or chilled water mode is a summer/winter changeover switch into one of the digital inputs. See Special Features for more information.

```

GENERAL SETTINGS
BMS Heat Cool Mode:
      NO
NOTE: If set to yes,
other mode will be
locked out.
Current Mode: Heat
    
```

6.5.4.1 Dual Temperature Coil Mode

The mode is determined by the OA temperature and the heating and cooling lockout temperature settings as well as the BMS command. Both heating or cooling demand drive the same cooling command analog and cooling enable digital output.

```

CONTROL SETTINGS
      HEATING
Type      DualTempCoil
Setpoint  Adjust
Control   Supply Air
OA Lockout Above
              40.0°F
    
```

```

CONTROL SETTINGS
      COOLING
Type      CW Mod
SetP      Adjust
Control   Supply Air
OA Lockout Below
              70.0°F
    
```

6.5.4.2 Dual Temperature Coil Cooling Operation

This type of cooling modulates a 0–10VDC cooling command output using PI control to maintain the cooling setpoint. The KP and Ti can be adjusted to fine tune the control. The NO4 cooling enable contact is engaged whenever the cooling demand is at 1% or higher.

By default the valve is scaled 0-10 VDC but it can be changed to 2–10 VDC in the *I/O Configuration*.

```

I/O CONFIGURATION
Cooling Output
      2-10 Volts
    
```

6.5.4.3 Dual Temperature Coil Heating Operation

This type of heating modulates a 0–10VDC cooling command output using PI control to maintain the heating setpoint. The KP and Ti can be adjusted to fine tune the control. The NO4 cooling enable contact is engaged whenever the heating demand is at 1% or higher.

```

CONTROL SETTINGS
      HEATING
Dual Coil - Adjustable
Setpoint  75.2°F
KP        1.0
Ti        30
    
```

 NOTE: The valve control can be set directly from the BMS if you change Valve control to BMS.

6.5.4.4 Dual Temperature Coil System Monitoring

This screen is available for monitoring the system in *Unit Status*.

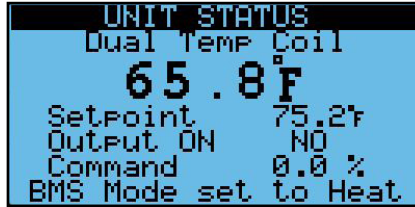

The Dual Temperature Coil status values are shown. Multiple values may be true.

MESSAGE	MEANING
Cool Locked Out by OA	The cooling OA lockout is lower than the OA temperature.
Heat Locked out by OA	The heating OA lockout is higher than the OA temperature.
Lockout Overlap	The OA lockouts for heating and cooling overlap. (No vent mode.) The heating takes preference.
Econ Only	If cooling is not on.
Econ Mode	If in economizer mode.
Unit OFF	Unit is off.
Set BMS Heat/Cool!!	In order to work properly, the BMS must be set to give a heat/ cool command.
BMS Mode set to Heat	BMS is setting the mode to heat. No cooling is allowed.
BMS Mode set to Cool	BMS is setting the mode to cool. No heating is allowed.
IN HEAT MODE	Valve is positioned for heat mode.
IN COOL MODE	Valve is positioned for cool mode.

### 6.6 ECONOMIZER CONTROL (BYPASS/FREE COOLING)

All units that are equipped with a bypass damper allow the incoming air to bypass the enthalpic plate when outdoor air conditions are more favorable. ERV units have two-position bypass, while DN units have modulating bypass. Thus, they operate slightly differently.

The standard economizer settings are:

- Disabled (No economizing)
- Temperature Diff—looks at the difference of RA and OA Temperature
- Enthalpy Diff—looks at the difference of RA and OA Enthalpy

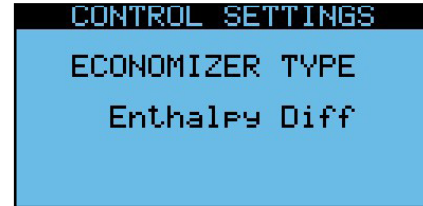
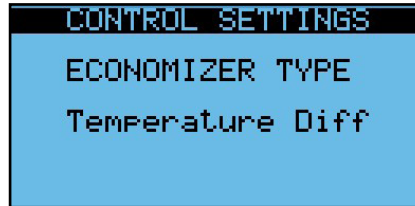

Two additional types are available, if required by specification, by unlocking those in the *Advanced Services* section.

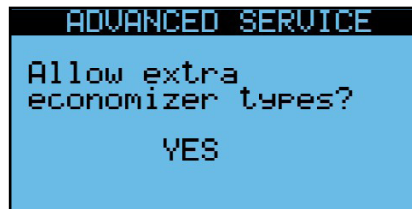

With that setting as YES, you will see these two additional options:

- OA Temp Limits—looks at the fixed OA Temperature
- OA Enth Limits—looks at the fixed OA Enthalpy and OA Temperature

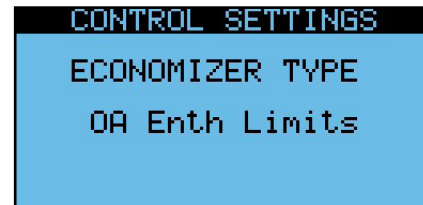
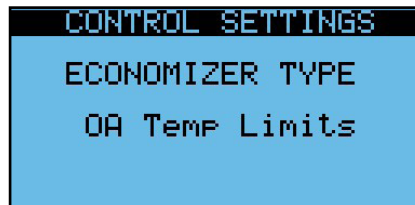

For your convenience, we have provided the ASHRAE90.1-2019 and Title 24-2019 specifications to use as guidance.

ASHRAE90.1-2019 SPECIFICATIONS		
ECONOMIZER TYPE	ALLOWED ASHRAE CLIMATE ZONE	REQUIRED HIGH LIMIT (ECONOMIZER OFF)
Fixed Dry Bulb	1b, 2b, 3b, 3c, 4b, 4c, 5b, 5c, 6b, 7, 8	TOA>75F (24C)
	5a, 6a	TOA>70F (21C)
	1a, 2a, 3a, 4a	TOA>65F (18C)
Differential Dry Bulb	1b, 2b, 3b, 3c, 4b, 4c, 5a,5b, 5c, 6a, 6b, 7, 8	TOA>TRA
Fixed Enthalpy + Fixed Dry Bulb	All	hOA>28 Btu/lb(66 kJ/kg) or TOA>75F(24C)
Differential Enthalpy + Fixed Dry Bulb	All	hOA>hRA, TOA>75F (24C)

TITLE 24-2019 SPECIFICATIONS		
ECONOMIZER TYPE	CALIFORNIA CLIMATE ZONE	REQUIRED HIGH LIMIT (ECONOMIZER OFF)
Fixed Dry Bulb	1, 3, 5, 11-16	TOA>75F (24C)
	2, 4, 10	TOA>73F (23C)
	6, 8, 9	TOA>71F (22C)
	7	TOA>69F (21C)
Differential Dry Bulb	1, 3, 5, 11-16	TOA>TRA
	2, 4, 10	TOA>TRA-2F(1C)
	6, 8, 9	TOA>TRA-4F(2C)
	7	TOA>TRA-6F(3C)
Fixed Enthalpy + Fixed Dry Bulb	All	hOA>28 Btu/lb(66 kJ/kg) or TOA>75F(24C)

6.6.1 Economizer Based on Temperature Difference Sequence

When the OA temperature is below the RA temperature less the hysteresis value, the economizer will bypass the core with incoming air. The economizer will be locked out when any of these it true:

- The OA temperature is less than the OA Temp Lockout
- The RA temperature is below the RA Temp Lockout
- Tempering mode is Heating (see Heating OA Lockout)

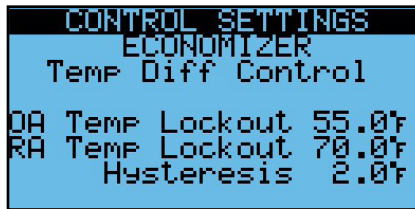

6.6.2 Economizer based on Enthalpy Difference Sequence

When the OA enthalpy is below the RA enthalpy less the hysteresis value, the economizer will bypass the core with incoming air. The economizer will be locked out when any of these it true:

- The OA temperature is less than the OA Temp Lockout
- The RA temperature is below the RA Temp Lockout
- Tempering mode is Heating (see Heating OA Lockout)

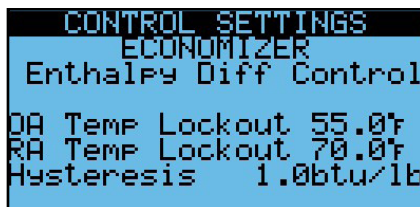

6.6.3 Economizer Based on OA Temperature Limits

The economizer will bypass the core with incoming air when OA is favorable. The economizer will be locked out when any of these it true:

- The OA temperature is less than the OA Temp Low Lim
- The OA Temp is above the Hi Lim
- Tempering mode is Heating (see Heating OA Lockout)

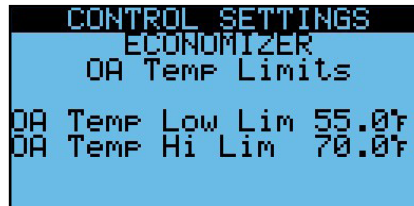

6.6.4 Economizer Based on OA Enthalpy Limits

The economizer will bypass the core with incoming air when OA is favorable. The economizer will be locked out when any of these it true:

- The OA enthalpy is greater than the OA Enth Lim
- The OA Temp is above the Hi Lim
- The OA Temp is below the Low Lim
- Tempering mode is Heating (See Heating OA Lockout)



6.6.5 Modulating Bypass Settings

The DN units have modulating bypass. For any unit that has cooling enabled, the bypass damper will modulate to maintain the cooling setpoint. Any mechanical cooling will be held off until the bypass damper is open to 100%. The following parameters are available to adjust the control response.

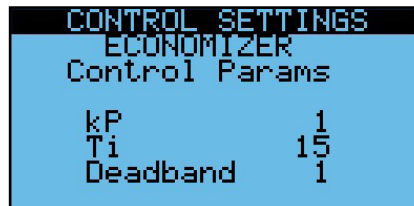

6.6.6 Monitoring the Modulating Bypass Status

The following screen allows you to see the status of the modulating bypass if available.

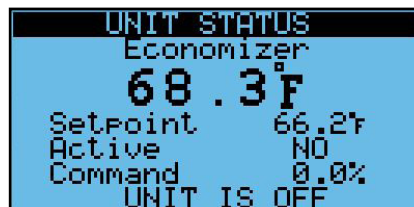

## 7.0 SPECIAL FEATURES

These features are not common but are available in the controller.

### 7.1 FROST CONTROL

This function is usually used in northern states and Canada. To enable the frost control functionality for these units the Enable Frost Cntl must be set to YES in the Unit Configuration (password protected) screen.

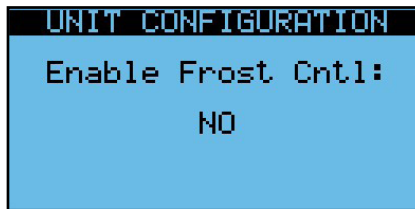

In the Control Settings you will be prompted to select a Frost Control Type. The two choices are OA Temp setpoint, where the OA Temp when Frost Control starts is entered manually, and RA Dewpoint Offset, where the controller chooses the OA temperature based on the RA dewpoint. The latter should not be used if the RA is not at least 70°F or if the flows are more than 90% unbalanced. This setting will most always save energy in situations where there is no active humidification.

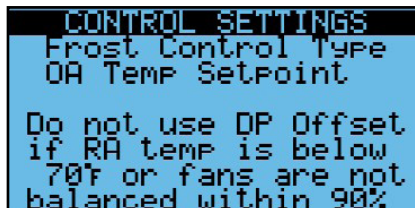

For ERV units, the frost control function disables the supply fan and closes the OA damper when the following conditions are met:

- The OA temperature is less than the OA Below setpoint
- The EA temperature (sensed at the inlet to the EA fan—average exhaust air temperature) is below the EA Below setpoint.

It will turn back off when the EA Above setpoint is reached provided the minimum frost control time (prevents over-cycling).



For variable speed fans, an additional setting is required for the exhaust fan operation. While the supply fan is off, a variable speed exhaust fan (ECM or VFD) will operate at the command set by the FC Exh Command setpoint. This command allows the user to minimize the negative space pressure that will be generated with the EF on and the SF off during frost control. For fans that are not variable speed, the exhaust fan will run at the normal speed and this setting will not be shown.

The frost control mode ends (OA damper is opened and the supply fan is enabled) when the EA temperature increases to the EA Above setpoint. The unit then resumes the selected normal operating mode. If the EA temperature then falls below the OA Below setpoint frost control mode is enabled again. There is a Unit Status screen that will appear if frost control function is enabled.

```

UNIT STATUS
FROST CONTROL
Active NO
EA Actual      58.7°F
EA Setpoint On 25.0°F
EA Setpoint Off 35.1°F
OA Actual      50.7°F
OA Setpoint    5.0°F
    
```

For DOAS units with modulating bypass, the frost control function modulates the bypass damper to maintain an EA setpoint when the following conditions are met:

- The OA temperature is less than the OA Below setpoint.

```

CONTROL SETTINGS
Frost Control Settings
Turn On When:
  OA Below      5.0°F
  EA Below     25.0°F
Turn Off When:
  EA Above     35.1°F
FC Exh Command 50.0%
    
```

There is a Unit Status screen that will appear if frost control function is enabled.

```

UNIT STATUS
FROST CONTROL
Active NO
EA Actual      73.7°F
EA Setpoint    35.1°F
Damper Command 0.0%
OA Actual      74.9°F
OA Low Limit   5.0°F
    
```

### 7.2 SINGLE FAN MODE

In some cases the application may require that only one fan run. The single fan mode is initiated by either closing the ID2 contact (gray DIN terminal connected to COM) or a BMS command to BMSEFOnly variable. It is BV11 for BACnet and Coil 1 for Modbus, where 0 = No and 1 = Yes. The default is Exhaust Fan but it can be changed to Supply Fan here. If tracking the supply fan, also set a value for exhaust fan in single fan mode.

```

I/O CONFIGURATION
Single Fan Mode Select
Used with ID2 input
Choose fan:
  Exhaust Fan
If EF and tracking,
run EF at: 50%
    
```

### 7.3 LIMIT SETPOINT RANGES FOR USERS

It is possible to set different limits for the heating and cooling occupied and unoccupied setpoints. The defaults are shown in these screens. This will limit the users in the front non-password protected screens from setting extreme setpoints.

```

I/O CONFIGURATION
Occ HTG Setpt Limit
  LOW = 41°F
  HIGH = 118°F

Unocc HTG Setpt Limit
  LOW = 41°F
  HIGH = 118°F
    
```

```

I/O CONFIGURATION
Occ CLG Setpt Limit
  LOW = 41°F
  HIGH = 118°F

Unocc CLG Setpt Limit
  LOW = 41°F
  HIGH = 118°F
    
```

## 7.4 ADJUSTMENTS FOR TWO-STAGE COOLING

There are several special settings for the two-stage cooling.

- In cases where the condensing unit is tied to only the first compressor, set only allow comp 2 is comp 1 in on: to YES. (Because of minimum off times it is normally possible that the second compressor turns back on before the first).
- Interstage delay: there is a delay between when the compressors are allowed to stage. It is defaulted to 180s.
- Normally the second compressor turns off at the same percentage that the first turned on and the first turns off at setpoint. If you set Specify Off Values: to YES, it will turn them off at the values specified.

```

I/O CONFIGURATION
Two Stage Comp Special
Only allow comp 2 if
comp 1 is on:    NO
Interstage Delay:
                180s
  
```

```

I/O CONFIGURATION
Two Stage Comp Special
Specify off values:
                NO
Stage 1 off:    0%
Stage 2 off:    50%
(Not used if NO)
  
```

## 7.5 TURN UNIT ON AND OFF BASED ON CO2 LEVEL

The system allows you to turn the unit on and off based on CO2 Level. This is useful when the ERV has been added specifically to give more fresh air to a space when occupied, such as a church.

The CO2 sensor must be enabled and installed.

```

I/O CONFIGURATION
User Added Sensors
CO2/VOC:    YES
Duct Static: NO
CA Temp Req:    NO
Cool LAT Temp Req NO
  
```

The feature needs to be enabled.

```

I/O CONFIGURATION
CO2 Level Unit On/Off
Feature Enabled: YES
This feature is used
in applications like
churches.
  
```

The setting for CO2 level to turn off is set, as well as a hysteresis value that is added to this to turn on and one that is subtracted from this to turn off.

```

CONTROL SETTINGS
CO2 On/Off
CO2 Lvl Off:    500PPM
To prevent cycling:
Hyst to off:    100PPM
Hyst to On:     100PPM
  
```

## 7.6 FLUSH FEATURE

The flush feature is used in conjunction with the scheduler function that allows you to set the unit into flush mode for specific time periods where the exhaust fan and supply fan will run at a specified CFM or % during this period.

It is enabled in the *I/O Configuration* screen. You can also set whether the fans will run to a specified % or CFM.

```

I/O CONFIGURATION
  FLUSH SETTINGS
  Used with Scheduler

Enable:                YES
Fan Set Type:%
  
```

Depending upon the last setting, you will see either one of these screens to allow you to define how the fans will run while in flush mode.

```

I/O CONFIGURATION
  FLUSH SETTINGS
  Used with Scheduler

SF in Flush:   100%
EF in Flush:   100%
  
```

```

I/O CONFIGURATION
  FLUSH SETTINGS
  Used with Scheduler

SF in Flush:   589CFM
EF in Flush:   589CFM
  
```

Once these settings are done, you will now have a third type of mode for the scheduler called FLUSH, as shown. In this example the unit will go into flush mode at 6:45 until 7:00 when it will turn on and run normally. During flush mode the OA and RA dampers (if included) will be open as in normal operation.

```

DAILY EVENTS
Day: Monday
Copy to: MON      Ok? No
 1 06:45 FLUSH
 2 07:00 ON-
 3 17:00 OFF
 4 --- -- ---
Save data?                Yes
  
```

## 7.7 COLD WEATHER OPERATION

The ERV has a built-in feature for detecting low temperatures to avoid dumping cold air into the space. The settings are shown in the following screen.

```

ALARM SETTINGS
SA Low Temp Warning
  Lower Limit -22.0f
  Delay Time  30 sec

SA Low Temp Alarm
  Lower Limit -22.0f
  Delay Time  30 sec
  
```

Be sure to make sure these settings are appropriate for your application.

- If the SA Temperature falls below the low warning temperature for the delay time while the supply fan is running, the warning will sound but the unit will remain running.
- If the SA Temperature falls below the low alarm temperature for the delay time while the supply fan is running, the alarm will sound but the unit will shut down and require a manual reset to start again.

In versions 4.00.xx and higher, a new setting was added. This function uses the warning levels to shut the unit down. It will then start the unit every duration timeframe to see if the SA conditions have improved. During this time, the unit will either turn the unit off (with warning notification) or run the exhaust fan only at a specific speed.

This feature was added to avoid having to continually reset the low temp alarm in cold periods as the alarm is a manually reset alarm.

The exhaust fan operation is designed for convenience stores, for example, where they may want to continually run a bathroom fan at a lower speed during these times.

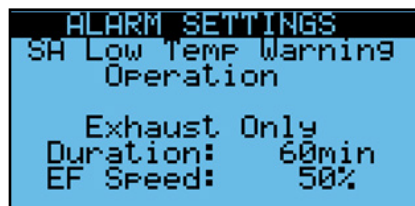
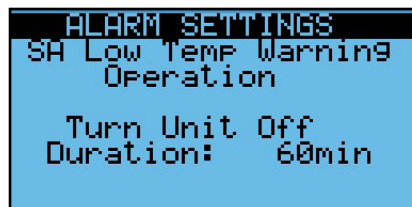
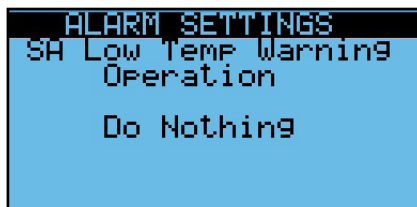

For systems that control heat, the settings are shown in the following screen.

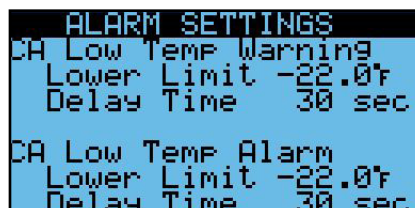

- If the CA Temperature falls below the low warning temperature for the delay time while the supply fan is running and during heating, the warning will sound but the unit will remain running.
- If the CA Temperature falls below the low alarm temperature for the delay time while the supply fan is running and during heating, the alarm will sound but the unit will shut down and require a manual reset to start again

## 7.8 SMOKE OR FREEZESTAT DEDICATED INPUT

This feature was added in version 03.00.41

It is possible to dedicate either digital input for a smoke and/or freezestat alarm which will shut down the unit and issue a manual reset alarm when engaged.

To use this feature, go to the I/O Configuration area and view this screen. The default for ID1 is DI On/Off and the default for ID2 is Single Fan Mode.

```

I/O CONFIGURATION
D19 Inputs Used For
ID1:DI On/Off
ID2:Sing Fan Mode
Must be different!
  
```

Change the input(s) to your desired alarms. Make sure you do not duplicate them. Shown is a sample but either input can be used for either alarm.

```

I/O CONFIGURATION
D19 Inputs Used For
ID1:Freezestat
ID2:Smoke Alarm
Must be different!
  
```

Once you do that, you will see either of these screens show up accordingly. Make sure you set the action for either *Open is ON* or *Open is Off*.

```

I/O CONFIGURATION
Smoke Alarm
Action
Open is OFF
  
```

```

I/O CONFIGURATION
Freezestat Alarm
Action
Open is OFF
Alarm only if on? NO
Delay from on: 0s
  
```

You will also have the additional manual reset alarm(s) according to your selection:

- AL08: Smoke Alarm
- AL09: Freezestat Alarm

## 7.9 BOOST MODE

This feature allows the user to designate an unused digital input (ID1 or ID2) as a boost input that will boost an ERV running in constant speed or constant flow mode to a “boost” level set in the screen or through BACnet.

In order to enable the feature, assign Boost Mode to one of the inputs in the *I/O Configuration*.

```

I/O CONFIGURATION
D19 Inputs Used For
ID1:Boost Mode
ID2:Sing Fan Mode
Must be different!
  
```

In the *Control Settings*, you will now see that you have two extra screens that appear for Supply and Exhaust Fan settings provided you have set the fans for constant speed control or flow control.

If the supply fan is set for flow control, for example, and the exhaust fan is set for tracking, the exhaust fan will track the boosted supply fan automatically.

This feature is not available for fans controlled by pressure or CO2 levels.

```

CONTROL SETTINGS
SUPPLY FAN
CONSTANT SPEED

Setpoint for
BOOST MODE
50%
  
```

```

CONTROL SETTINGS
EXHAUST FAN
CONSTANT SPEED

Setpoint for
BOOST MODE
50%
  
```

## 7.10 H<sub>2</sub>O LEAK DETECT

It is possible to dedicate either digital input for H<sub>2</sub>O leak detected alarm which will shut down the unit and issue an automatic reset alarm when engaged.

To use this feature, go to the *I/O Configuration* area and view this screen. The default for ID1 is DI On/Off and the default for ID2 is Single Fan Mode.

```

I/O CONFIGURATION
D19 Inputs Used For
ID1:H2O Leak Detect
ID2:Sing Fan Mode
Must be different!
  
```

### 7.11 UNOCCUPIED OVERRIDE

In units with recirculation dampers for unoccupied operation, either digital input can be designated as an occupancy override. This could be a switch or an occupancy sensor, for example.

```

I/O CONFIGURATION
D19 Inputs Used For
ID1: DI On/Off
ID2: Occ Override
Must be different!
  
```

Whenever the input is closed and the unit is operating in unoccupied mode, the unit will operate in occupied mode, maintaining the occupied heating and cooling setpoints, until the switch is opened again.

### 7.12 SMOKE PURGE

This feature can be used with a fire switch to purge the space after a smoke incident has occurred. It utilizes one of the digital inputs.

```

I/O CONFIGURATION
D19 Inputs Used For
ID1: DI On/Off
ID2: Smoke Purge
Must be different!
  
```

The action can be set for Open is OFF or Open is On. If on, the unit will run the supply and exhaust fans according to the settings shown during that period. This will occur whether the unit is off or on.

```

I/O CONFIGURATION
Smoke Purge
Action: Open is OFF
Enable SF?      NO
SF Purge %:     80%
Enable EF?      NO
EF Purge %:     80%
  
```

### 7.13 PREHEATER

The controller can control a preheater to maintain a minimum incoming outdoor temperature with a 0–10 VDC signal to a heater. In order to do this, you must set U8 to Preheater. (It cannot be used if modulating HGRH is used.)

```

I/O CONFIGURATION
U8 0-10 VDC Output
(Expansion Module)

Preheater
  
```

Once enabled, a screen will show up in the Control Settings that allows you to set the setpoint and PI parameters.

```

CONTROL SETTINGS
Preheat Setting
OA Low Limit: 32°F
  KP 1.0
  Ti 30
  
```

The status can be viewed in this *Unit Status* screen.

```

UNIT STATUS
PREHEATER
OA Temp SetP: 32.0°F
OA Temp: 32.0°F
Preheat Cmd: 0.0%
  
```

## 7.14 SUMMER/WINTER CHANGEOVER

With two-pipe, dual temp systems which use one water coil for both heating and cooling we need to know if the mode is heating or cooling. This can be done through the BMS. It can also be done through one of the digital inputs.

```

I/O CONFIGURATION
DI9 Inputs Used For
ID1: DI On/Off
ID2: Summer/Winter
Must be different!
  
```

You must also specify whether contact open is winter or summer in this screen.

```

I/O CONFIGURATION
Summer/Winter
Changeover Input
Open is Winter
Closed is Summer
  
```

If you choose this input the BMS option is not available.

## 7.15 SWAP AIRFLOWS

For ERVs without bypass, if you need to swap the OA and RA airflow, the controller will accommodate that without any rewiring. You can do this on this screen in the *Advanced Services* section.

```

ADVANCED SERVICE
Swap OA and RA Airflow
Swapped
Not available for
units with bypass.
If swapped, change
labels accordingly.
  
```

You will now see they are swapped in the *Unit Status* screen with the version information. Be sure to change the labels in the unit. You can request new labels through TSS.

```

UNIT STATUS
*RenewAire ERV/DOAS*
Code:USRNAeERVN
      Swapped
SW ver.: 4.0.009
DS ver.: 0.0.000
          00000000000000000000
    
```

**7.16 REFRIGERANT LEAK DETECTION MITIGATION**

All DN units with DX coils automatically come with the refrigerant leak detector installed on ID2. For other types of units an accessory is available, PN 301282. To use the sequences set one of the two digital inputs to Refrig Leak.

```

I/O CONFIGURATION
Dig Inputs Used For
ID1: DI On/Off
ID2: Refrig Leak
      Must be different!
    
```

You will also need to set the input type to Normally Closed or Normally Open. Our sensor uses Normally Closed. You can also set the fan speed commands, default 100%. The type of alarm is also selectable between:

- auto reset—will resume operation once fault has cleared
- man reset—will require someone to manually reset the alarm before resuming operation
- auto Until—will be an auto alarm unless it occurs 3 times within 2 hours (7200s), at which time it will need to be manually reset. The number of occurrences and the time within are both adjustable

```

I/O CONFIGURATION
Refrig Leak Input
Type: Normally Closed
Fan Settings:
SF Run: 100%
EF Run: 100%
Alrm Type: Auto Until
Times:3 Within: 7200s
    
```

If a refrigerant leak is detected, the unit will shut down any electric or gas heat and turn off any compressors while running the fans at the given speeds. This occurs whether the unit was on or not.

**7.17 UNIT ON/OFF OUTPUT**

If you require an additional component such as a damper or fan to turn on and off according to the unit condition it is possible to use one of the alarm output NO6 to do this. The output has both normally open and normally closed contacts. If you have frost control enabled it will also ask if you want that condition to be considered as unit off.

```

I/O CONFIGURATION
NO6 Functionality
Cntrl: Unit On
Exp1: Any Alarm
    
```

```

I/O CONFIGURATION
NO6 Functionality
Cntrl: Unit On
Exp1: Any Alarm
Consider SA Off by
Frost Control as Unit
Off? YES
    
```

### 7.18 MULTIPLE CO2 SENSORS

For units that feed more than one zone it is possible to support up to four CO2 sensor inputs. The controller will automatically use the highest value to control based on a CO2 setpoint or change the flow based on that value with demand-controlled ventilation.

To do this, set the CO2 sensor as the first sensor. Then for any of the unused inputs U4–U6, a screen will appear that allows you to set the other sensor to subsequent CO2 sensors.

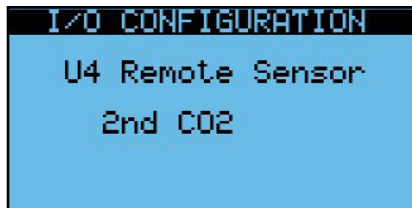
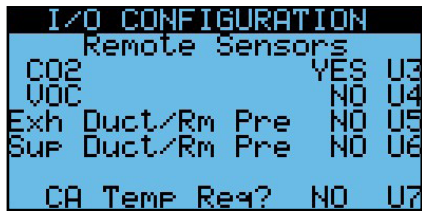

Each sensor is allowed to scale individually if using 0–10VDC sensors other than RenewAire type.

### 7.19 ADDITIONAL HUMIDITY SENSORS

You can select to add humidity sensors in the SA or EA airstreams. This can be useful if you are calculating effectiveness for energy calculations.

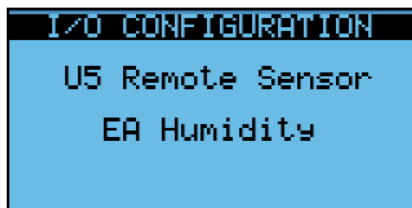
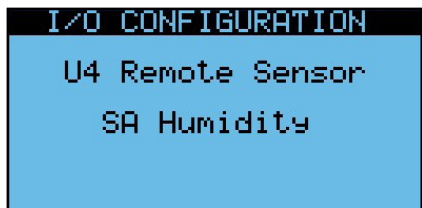

## 8.0 VERIFYING I/O AND UNIT WIRING

All of the I/O values should be verified and calibrated, if necessary.

### 8.1 VERIFYING ALL I/O THROUGH UNIT STATUS SCREENS

All of the individual I/O are able to be viewed in one place by pressing “ENTER” when on this screen, which is located toward the end of *Unit Status*.



There will be individual screens for each input and output. Several examples are shown.

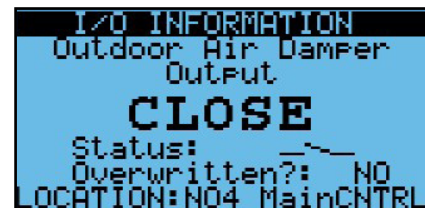
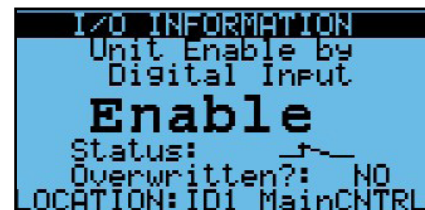
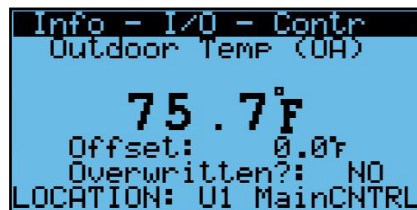

### 8.2 CALIBRATING I/O

For a temperature sensor that may have run a long distance or a humidity sensor with a reading that may have drifted over time, a calibration may be necessary. There is a screen such as the one shown for each sensor and transducer. The current value at the top will reflect the change with the offset that is set in this screen.



### 8.3 GENERAL UNIT CONTROL WIRING

The following tables and diagrams show the general unit control wiring for the ERV units. A unit-specific electrical schematic is found inside the access door to the core module.

#### 8.3.1 Sensor Inputs

Sensors in Gray are optional, and field-installed.

SENSOR	TYPE	SENSOR TERMINALS	CONTROLLER TERMINALS
OA Temperature	Tasseron NTC and 0–10VDC	T Far Left (Brown)	U1 (Main)
OA Humidity		T 2 (Black)	Black DIN
		+ 3 (Red)	Red DIN
		- 4 (Black)	Black DIN
		0 5 (Green)	U2 (Main)
RA Temperature	Tasseron NTC and 0–10VDC	T Far Left (Red)	U3 (Main)
RA Humidity		T 2 (Black)	Black DIN
		+ 3 (Red)	Red DIN
		- 4 (Black)	Black DIN
		0 5 (White)	U4 (Main)
SA Temperature	CAREL NTC	(Red or White)	U5 (Main)
EA Temperature	CAREL NTC	(Black)	GND (Main)
		(Red or White)	U6 (Main)
OA Filter Pressure	0–10VDC	(Black)	GND (Main)
		VAC/V+ (Red)	Red DIN
		COM/GND (Black)	Black DIN
RA Filter Pressure	0–10VDC	VOUT/OUT (Blue)	U7 (Main)
		VAC/V+ (Red)	Red DIN
		COM/GND (Black)	Black DIN
OA Flow Rate Pressure	0–10VDC	VOUT/OUT (Blue)	U8 (Main)
		VAC/V+ (Red)	Red DIN
		COM/GND (Black)	Black DIN
RA Flow Rate Pressure	0–10VDC	VOUT/OUT (White)	U1 (Exp)
		VAC/V+ (Red)	Red DIN
		COM/GND (Black)	Black DIN
CO2 Level Sensor*	0–10VDC	VOUT/OUT (White)	U2 (Exp)
		PWR	Red DIN
		COM	Black DIN
VOC Level Sensor (ERV) or Modulating Bypass Damper (DOAS)*	0–10VDC	CO2 Output	U3 (Exp)
		PWR	Red DIN
		COM	Black DIN
Exhaust Duct or Room Pressure Sensor*	0–10VDC	VOC Output	U4 (Exp)
		VAC/V+	Red DIN
		COM/GND	Black DIN
Exhaust Duct or Room Pressure Sensor*	0–10VDC	VOUT/OUT	U5 (Exp)
		VAC/V+	Red DIN
		COM/GND	Black DIN
CA Temp Sensor	CAREL NTC	VOUT/OUT	U6 (Exp)
		(Red or White)	U7 (Exp)
		(Black)	GND (Exp)

\* If I/O is unused, it may be assigned to a different input in I/O Configuration.

8.3.2 Digital Inputs

Inputs in Gray are optional, and field-installed.

 **NOTE:** You can dedicate the smoke detector to an input to get a specific smoke alarm. See *Special Features* section.

INPUT	TYPE	INPUT TERMINALS	CONTROLLER TERMINALS
Smoke Detector	Dry Contact		Orange DIN
			Black DIN
ID1 Unit Enable* (unless designated for other use)	Dry Contact		Orange DIN
			Black DIN
ID2 Single Fan Mode (unless designated for other use)	Dry Contact		Gray DIN
			Black DIN
SF Current Switch (SF Status)	Dry Contact	(Black)	GND (Main)
		(Red)	U9 (Main)
EF Current Switch (EF Status)	Dry Contact	(White)	GND (Main)
		(Red)	U10 (Main)

\* Some units have the doorkill switch wired into this input. Consult the wiring diagram on your unit to verify.

## 8.3.3 Digital Outputs

Outputs in Gray are optional, and field-installed. Heating and cooling would be field-installed. Dampers could be factory or field-installed.

OUTPUT	TYPE	OUTPUT TERMINALS	CONTROLLER TERMINALS
SF Enable	Dry Contact	(See wiring diagram)	N01 (Main)
			C1/2 (main)
EF Enable	Dry Contact	(See wiring diagram)	N02 (Main)
			C1/2 (main)
Two-Position Bypass (ERV) or Recirc damper (DOAS)	Dry Contact	HOT (Orange)	N03 (Main)
		COM (Purple)	Accy COM (White)
OA Damper	Dry Contact	HOT (Red)	N04(Main)
		COM (Black)	Accy COM (White)
RA Damper	Dry Contact	HOT (Red/Brown)	N05 (Main)
		COM (Black/Purple)	Accy COM (White)
Serious Alarm Output	Dry Contact*		N06/NC6 (Main)
			C6 (Main)
Heating Enable 1	Dry Contact*		N01 (EXP)
			C1/2 (EXP)
Heating Enable 2 or two-position HGRH	Dry Contact*		N02 (EXP)
			C1/2 (EXP)
Tempering Mode	Dry Contact*		N03 (EXP)
			C3/4/5 (EXP)
Cooling Enable 1 (or Heat Pump 1)	Dry Contact*		N04(EXP)
			C3/4/5 (EXP)
Cooling Enable 2 (Or Heat Pump 2)	Dry Contact*		N05 (EXP)
			C3/4/5 (EXP)
Any Alarm Output	Dry Contact*		N06/NC6 (EXP)
			C6 (EXP)

\*There is an option to use 24VAC ACCY power if it is needed to drive a 24VAC relay. For example, to drive a cooling stage 1 relay, wire as follows:

- Accy 24VAC (Blue DIN terminal) connected to EXP C3/4/5
- EXP N04 Cooling stage 1 connected to one side of the 24VAC relay coil.
- Accy COM (White DIN Terminal) connected to the other side of the 24VAC relay coil.

## 8.3.4 Analog Outputs

Outputs in Gray are optional, and field-installed. Heating and cooling may be factory-installed or field-installed, depending upon the unit.

OUTPUT	TYPE	CONTROLLER TERMINALS
SF Signal	0–10VDC	Y1 (Main)
		GND (Main)
EF Signal	0–10VDC	Y2 (Main)
		GND (Main)
HGRH Command or Preheater	0–10VDC	U8 (EXP)
		GND (EXP)
Cooling Command (or Dual Temp Command)	0–10VDC	U9 (EXP)
		GND (EXP)
Heating Command	0–10VDC	U10 (EXP)
		GND (EXP)

## 8.3.4.1 Wiring to Three-Wire Valves

For Cooling or Dual Temp valves, use the following wiring:

Sensor signal U9 (EXP)

Common Black DIN Terminal

24V Power to valve Red DIN Terminal

For Heating valves, use the following wiring:

Sensor signal U10 (EXP)

Common Black DIN Terminal

24V Power to valve Red DIN Terminal

8.3.5 Sample Power Wiring Schematic

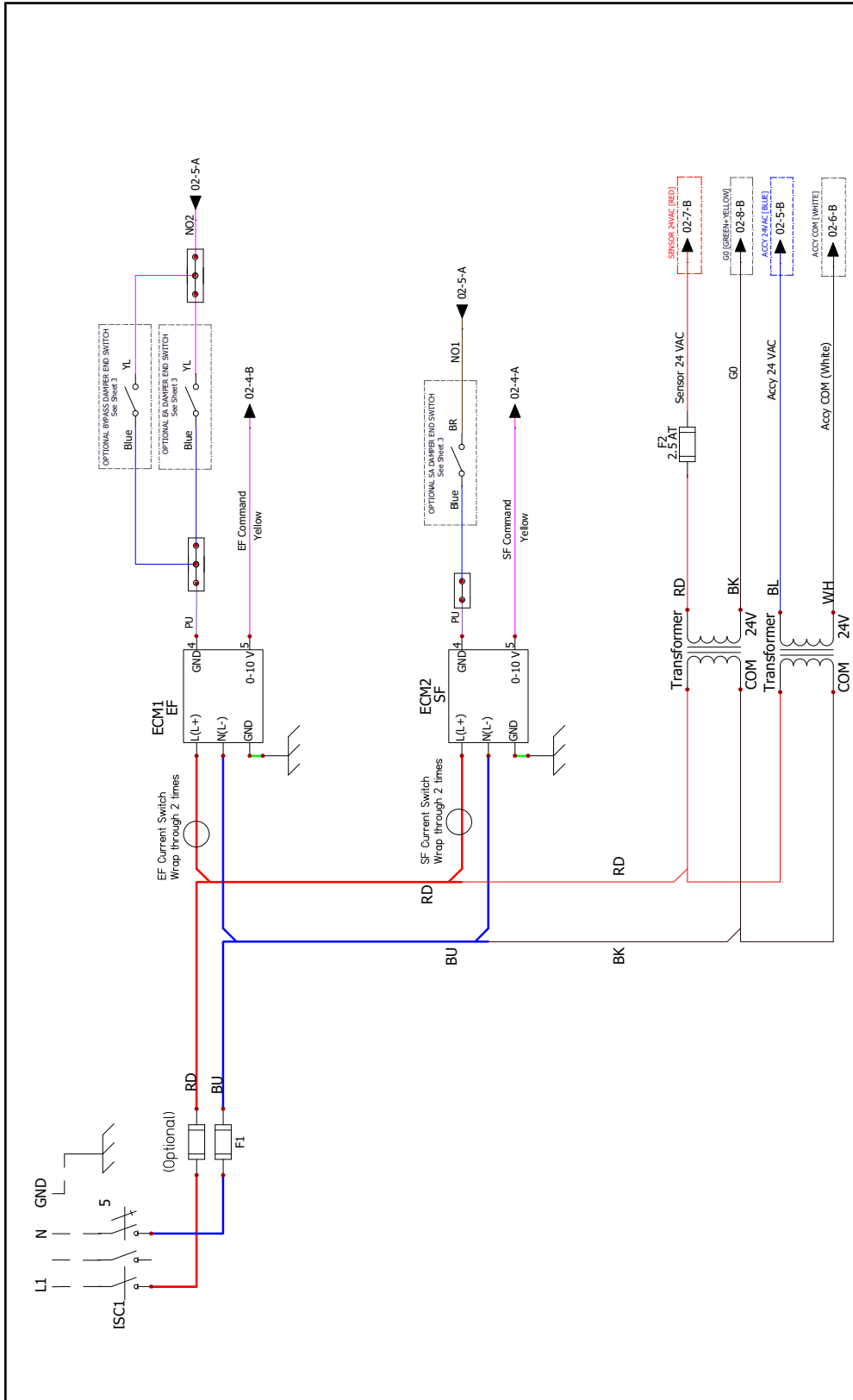

 **NOTE:** This wiring schematic is TYPICAL control wiring for a three phase, 460VAC input for model HE10-. A unit-specific electrical schematic is found inside the access door to the core module.



**NOTE:** This wiring schematic is TYPICAL control wiring. A unit-specific electrical schematic is found inside the access door to the core module.

8.3.6 Sample Control Wiring Schematic

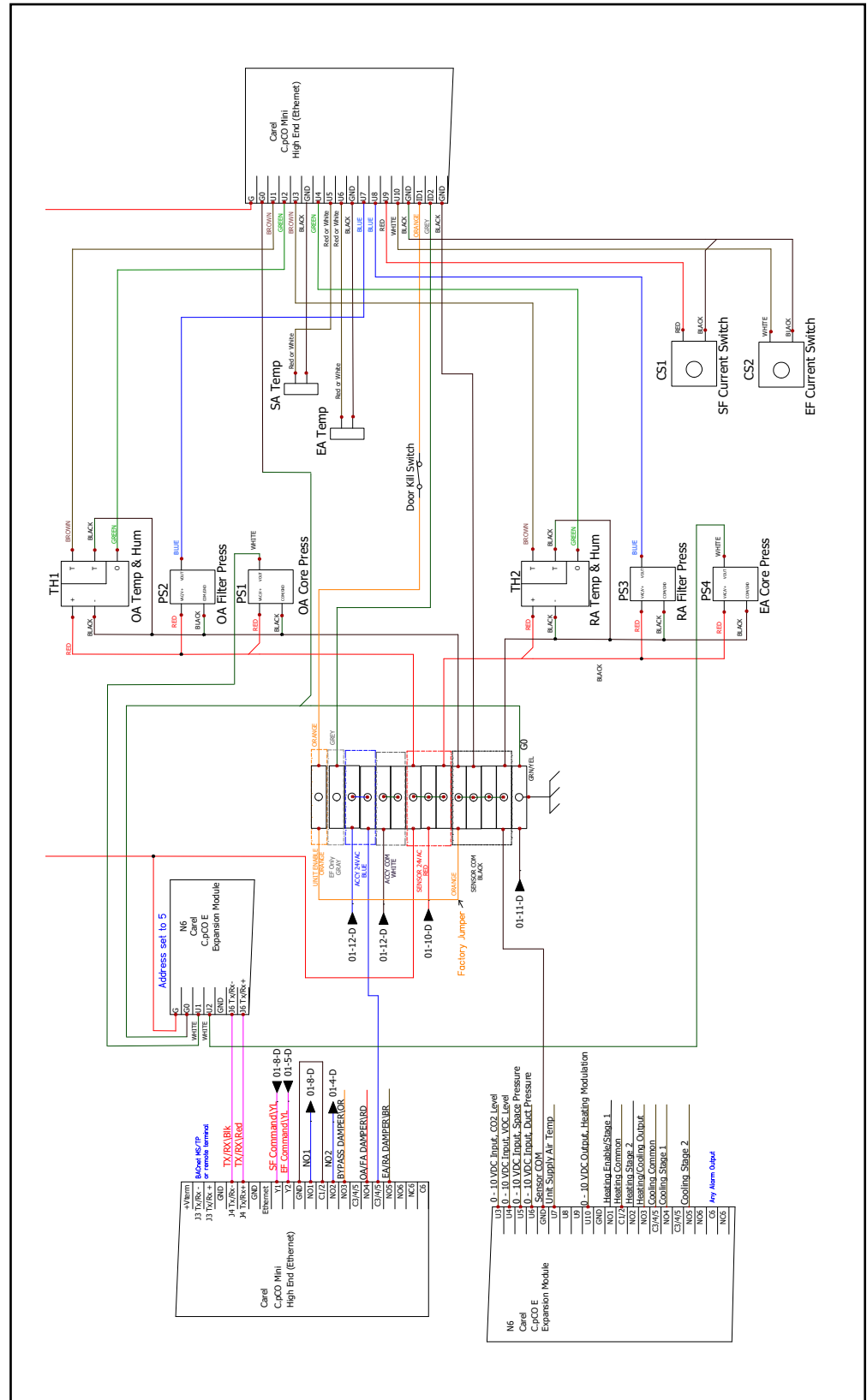



## 9.0 ALARMS AND TROUBLESHOOTING

If the problem is caused by an alarm, the first step in troubleshooting is to view the Alarm screens. Press the Alarm button on the face of the controller to see all current alarms and what function or component is causing the alarm. In some cases, the Alarm pre-set may need to be adjusted or an offset may need to be changed. Before making any changes to the controller programming, be certain to have an updated Backup file so that current settings can be easily restored, if needed. See the following *Alarms* section for these.

Problems with an air handler are sometimes strictly mechanical, in which a fan or damper or some other component simply stops working. Mechanical problems are easily traced to specific components by using the Test End Device feature in the service level. See the following *Test End Devices* section for this.

In other cases, problems may be caused by the air handler trying to overcome a pre-set or operating parameter that has been set by the user. In these cases, view the controller screens to trace the problem. See *Other Common Problems* section for these.

### 9.1 ALARMS

The alarms are viewed through the controller screen or through the BMS.

#### 9.1.1 Acknowledging Alarms

When an alarm occurs, you will hear a buzzer sound and the alarm light will flash. Press the alarm button to acknowledge the alarm and quiet the buzzer.

#### 9.1.2 Viewing Alarms and Alarm Log

If there are active alarms the alarm button will be red. To view the active alarms, press the alarm button. Each alarm has an alarm number (AL\*11, in this case), a time stamp, and a message to show which alarm occurred.

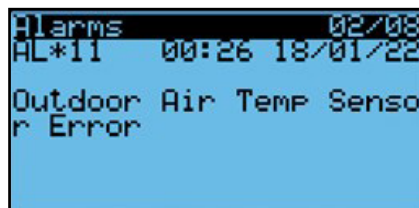

Continue to press the button to cycle through all active alarms. At the end you will see this screen. Here you can press "ENTER" to see the past alarms.



An alarm log screen looks like this. If the event is Stop, it shows the time that the alarm went away. If the event is Start, it shows the time that the alarm first occurred. There may be up to 50 entries.

```

Data logger Record:01
                14:32 14/03/22
Exhaust Air Flow Rate
Sensor Error
Event:          Start
  
```

If no alarms are active, the screen will say No Alarms but you can still press “ENTER” to view the last 50 alarm occurrences.

```

NO ALARMS
Press ENTER
to DATA LOGGER
  
```

### 9.1.3 Resetting Alarms

If you cycle through the alarms, you will see this screen. At this time, you can hold the alarm button down to reset the “User Reset” alarms. (The auto reset alarms reset themselves.)

```

Alarms
Press ALARM for 3s
to reset all alarms
Press ENTER
to DATA LOGGER
  
```

### 9.1.4 Alarm Digital Outputs

The controller includes a digital output for remote indication of an alarm condition.

The first is AlarmOut.val and it closes the contact if there is an alarm that will shut down the unit. These include:

- Low Supply Temperature Alarm
- High Supply Temperature Alarm
- Loss of communication between the controller and the expansion module
- Exhaust Fan Alarm (Failure to start)
- Supply Fan Alarm (Failure to start) ONLY IF the *SF Alarm Unit Run?* is set to No. If yes, the unit will not shut down and the exhaust fan will be allowed to continue to run. All heating and cooling functions will be locked out, however.

```

ALARM SETTINGS
Fan Alarm Delay
90sec
SF Alarm Unit Run?
NO
  
```

The second is AnyAlarmOut.val and it closes the contact if there is any alarm including the ones in AlarmOut.val.

The physical connection for the first is made at the controller and the second is made at the expansion module. Both are terminated at the same terminal, J12, located in the upper right corner. There is both a normally open (NO6 to C6) and normally closed (NC6 to C6) option.

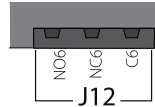

9.1.5 Specific Alarms and Their Meaning

The alarms are identified by number. They are grouped by type. Alarms 50–57, alarms 66–68.

9.1.5.1 General Alarms

NUMBER	NAME	STATUS SHOWN	MEANING
0	AI_retain	User reset	Error in the number of retain memory writings
1	AI_Err_retain_write	User reset	Error in retain memory writings
2	AI_Device_Test	Auto reset	Device Test is Running—Outputs Disabled!
3	AI_BMS_Offline	Auto reset	Device offline alarm to BMS
4	OfflineAlrm_CPCOE_1	Auto reset	Device offline alarm CPCOE
5	CfgErrAlrm_CPCOE_1	Auto reset	Wrong configuration on device CPCOE
8	AI_Smoke	User Reset	Smoke Alarm Input is engaged
9	AI_Freeze	User Reset	Freezestat Alarm Input is engaged

**Alarm Number 0:** Error in the number of retain memory writings

This usually means indicates that the BMS is writing to a retained setpoint too often. Retained values are stored in a special memory so that they are kept on power loss. Failure to correct this could result in damage to the controller.

**Alarm Number 1:** Error in retain memory writings

This usually means indicates that the BMS is writing to a retained setpoint too often. Retained values are stored in a special memory so that they are kept on power loss. Failure to correct this could result in damage to the controller.

**Alarm Number 2:** Device Test is Running—Outputs Disabled!

This alarm occurs if someone had the unit in device test mode and the time limit has passed, usually an hour. Either cycle power to the unit or go into the Device Test section in the password protected menus and turn it off.

**Alarm Number 3:** Device offline alarm to BMS

This alarm occurs if the BMS is enabled, and it is offline.

**Alarm Number 4:** Device offline alarm CPCOE

This alarm occurs if the controller and expansion module have lost communication. For correct operation the dipswitches are set (left to right) Forward, backward, forward, backward, forward, forward, forward, forward. This coincides with an address of 5. Sometimes if they have been moved around it is necessary to set them all to OFF (forward), cycle power, and then set them as required, and then cycle power again.

- Check the wiring: FBUS on the controller to BMS on the expansion.
- Check that the dipswitches are positioned correctly.



**NOTE:** The green LED indicates communication status on the BMS port. If there is communication on the BMS port (online) the green LED flashes, if there is no communication (offline) the LED stays on steady.

**Alarm Number 5:** Wrong configuration on device CPCOE

This alarm is an internal alarm. Contact TSS if this alarm occurs.

**Alarm Number 8:** In Special Features, either ID1 or ID2 may be dedicated to a smoke alarm input. This alarm indicated that the alarm is engaged.

**Alarm Number 9:** In Special Features, either ID1 or ID2 may be dedicated to a freezestat alarm input. This alarm indicated that the alarm is engaged.

#### 9.1.5.2 Supply and Exhaust Alarms

NUMBER	NAME	STATUS SHOWN	MEANING
10	AI_SupplyFan	User reset	Supply Fan Alarm
11	AI_ExhaustFan	User reset	Exhaust Fan Alarm

#### Alarm Number 10: Supply Fan Alarm

This indicates that either the supply fan did not start, or that the current switch did not register the supply fan as running. Refer to the Supply or Exhaust Fan Alarm Troubleshooting section in the Test End Devices.

The delay for this alarm is set here. The setting is shared with the exhaust fan. Whether the unit shuts down if this alarm occurs is also set here.



#### Alarm Number 11: Exhaust Fan Alarm

This indicates that either the exhaust fan did not start, or that the current switch did not register the exhaust fan as running. Refer to the Supply or Exhaust Fan Alarm Troubleshooting section in the Test End Devices.

The delay for this alarm is set here. The setting is shared with the supply fan. This alarm will shut the unit down.



## 9.1.5.3 Airflow Condition Alarms

NUMBER	NAME	STATUS SHOWN	MEANING
12	AI_SA_Airflow	Auto reset	Supply Airflow Alarm
13	AI_EA_Airflow	Auto reset	Exhaust Airflow Alarm
14	AI_SA_PressTol	Auto reset	SA Static Pressure Level Alarm
15	AI_CO2	Auto reset	CO2 Level Alarm
16	AI_SupAir_Low_Temp_Warn	Auto reset	Low SA Temp Warning
17	AI_SupAir_Low_Temp_Alarm	User reset	Low SA Temp Shutdown
18	AI_SupAir_Hi_Temp_Warn	User reset	High SA Temp Warning
19	AI_SupAir_Hi_Temp_Alarm	User reset	High SA Temp Shutdown
20	AI_VOC	User Reset	VOC Alarm
21	AI_EA_PressTol	Auto reset	EA Static Pressure Level Alarm
22	AI_H2OLeak	Auto Reset	H2O Leak is detected.

**Alarm Number 12: Supply Airflow Alarm**

This alarm occurs when the supply is set to control on supply flow (CFM). It indicates that the flow measured is out of tolerance set here for more than the alarm delay set here.

```

ALARM SETTINGS
SF Airflow Tolerance
  80.0%
>100% disables alarm

Airflow Alarm Delay
  60 sec

```

This usually indicates that the unit is probably hunting and the KP (gain) for the PI control needs to be adjusted. Set the KP to 0.1 or 0.2 to start. If it responds too slow, you can increase it but these values are usually acceptable.

```

CONTROL SETTINGS
SUPPLY FAN
AIRFLOW CONTROL
Setpoint: 294cfm
  KP  0.1
  Ti  35
Start %: 30 Delay120s
Min %: 25

```

**Alarm Number 13: Exhaust Airflow Alarm**

This alarm occurs when the supply is set to control on exhaust flow (CFM). It indicates that the flow measured is out of tolerance set here for more than the alarm delay set here.

```

ALARM SETTINGS
EF Airflow Tolerance
  80.0%
>100% disables alarm

Airflow Alarm Delay
  60 sec

```

This usually indicates that the unit is probably hunting and the KP (gain) for the PI control needs to be adjusted. Set the KP to 0.1 or 0.2 to start. If it responds too slow, you can increase it but these values are usually acceptable.

```

CONTROL SETTINGS
EXHAUST FAN
AIRFLOW CONTROL
Setpoint: 294cfm
  KP 1.0
  Ti 30
Start %: 30 Delay120s
Min %: 25
  
```

#### Alarm Number 14 and 21: Supply and Exhaust Air Static Pressure Level Alarms

These alarms occur when the supply fan is set to control on duct static pressure, or the exhaust fan is set to control on return static pressure. It indicates that the pressure measured is out of tolerance set here for more than the alarm delay set here.

```

ALARM SETTINGS
SF Duct Press Tol
 10.0%
Pressure Alarm Delay
 120 sec
  
```

```

ALARM SETTINGS
EF Return Press Tol
 10.0%
Pressure Alarm Delay
 300 sec
  
```

First make sure the pressure sensor is enabled in the *I/O configuration* and that there is a reading in the *Unit Status*. If you don't see this screen the sensor is not enabled. If the sensor is not reading correctly, check the wiring and calibration screen.

```

Unit Status
Duct Pressure
 0.00"wg
Setpoint 0.00"wg
  
```

If the sensor is reading correctly, this usually indicates that the unit is probably hunting and the KP (gain) for the PI control needs to be adjusted. Decrease the KP to slow the response Increase to get a faster response.

```

CONTROL SETTINGS
SUPPLY FAN
DUCT STATIC CONTROL
Setpoint 0.50"wg
  KP 200.0
  Ti 25
Start %: 30 Delay120s
Min %: 25
  
```

```

CONTROL SETTINGS
EXHAUST FAN
DUCT STATIC CONTROL
Setpoint 0.50"wg
  KP 1.0
  Ti 30
Start %: 30 Delay120s
Min %: 25
  
```

**Alarm Number 15 and 20: CO2 or VOC Level Alarm**

This alarm occurs when the CO2 or VOC sensor is enabled, and the CO2 or VOC level rises above the level set in this screen for more that the delay time.



First make sure the pressure sensor is reading correctly in the *Unit Status*. If the sensor is not reading correctly, check the range settings in *I/O Configuration*, the wiring, and the calibration screen.



If the sensor is reading correctly, the CO2/VOC level is too high. You may have to adjust the fan control to keep it within limits.

**Alarm Numbers 16 and 17: Low SA Temp Warning and Low SA Temp Shutdown**

In units without heating, the alarm applies to the supply temperature (SA). In units with heating, this alarm applies to the unit supply temperature that is measured after the heating unit.

First, view the sensor value in *Unit Status*. If it seems OK, then check the alarm levels set here. (Only one will show, depending upon whether you have a Unit Supply Temp Sensor). The difference in the two is that the warning will just show as an alarm while the shutdown will shut down the unit. You can use the warning as a warning set at higher temperature for the purposes of warning. You can also just use one or the other by setting the limits of the one you do not want to use very low.

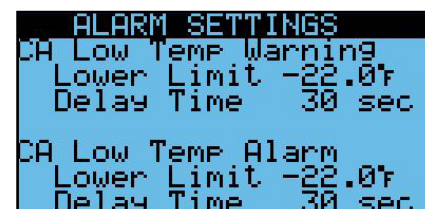
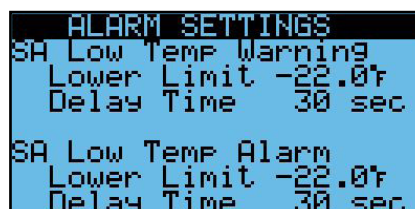
**Alarm Numbers 18 and 19: High SA Temp Warning and High SA Temp Shutdown**

This alarm only applies to units with cooling and applies to the CA Temperature.

First, view the sensor value in *Unit Status*. If it seems OK, then check the alarm levels set here. The difference in the two is that the warning will just show as an alarm while the shutdown will shut down the unit. You can use the warning as a warning set at lower temperature for the purposes of warning. You can also just use one or the other by setting the limits of the one you do not want to use very high.

```

ALARM SETTINGS
CA High Temp Warning
  Lower Limit 176.0°F
  Delay Time 500 sec

CA High Temp Alarm
  High Limit 176.0°F
  Delay Time 500 sec

```

#### 9.1.5.4 Sensor Alarms

NUMBER	NAME	STATUS SHOWN	MEANING
28	AI_SA_Hum_Prpb	Auto reset	SA Humidity Transducer Error
29	AI_EA_Hum_Prpb	Auto reset	EA Humidity Transducer Error
30	AI_OA_Temp_Prpb	Auto reset	OA Temperature Sensor Error
31	AI_OA_Hum_Prpb	Auto reset	OA Humidity Transducer Error
32	AI_RA_Temp_Prpb	Auto reset	RA Temperature Sensor Error
33	AI_RA_Hum_Prpb	Auto reset	RA Humidity Transducer Error
34	AI_SA_Temp_Prpb	Auto reset	SA Temperature Sensor Error
35	AI_EA_Temp_Prpb	Auto reset	EA Temperature Sensor Error
36	AI_OA_Flt_Press_Prpb	Auto reset	OA Filter Pressure Transducer Alarm
37	AI_RA_Flt_Press_Prpb	Auto reset	RA Filter Pressure Transducer Alarm
38	AI_OA_Flow_Rate_Prpb	Auto reset	OA Flow Rate Sensor Error
39	AI_EA_Flow_Rate_Prpb	Auto reset	EA Flow Rate Sensor Error
40	AI_CO2_Level_Prpb	Auto reset	CO2 Sensor Error
41	AI_Duct_Press_Prpb	Auto reset	SA Pressure Probe Error
42	AI_Supply_Temp_Prpb	Auto reset	CA Temperature Sensor Error
44	AI_VOC_Level_Prpb	Auto reset	VOC Sensor Error
43	AI_Coil_LAT_Prpb	Auto reset	Coil LAT Sensor Error
45	AI_SpacePress_Prpb	Auto reset	EA Pressure Transducer Error
46	AI_CO2_2_Prpb	Auto reset	2nd CO2 Sensor Error
47	AI_CO2_3_Prpb	Auto reset	3rd CO2 Sensor Error
48	AI_CO2_3_Prpb	Auto reset	4th CO2 Sensor Error

#### Alarm Numbers 28–48: Sensor Alarms

These alarms occur when the controller detects that sensor is not reading in the expected range. Passive sensors such as temperature sensors show an error when the controller detects a short circuit or open circuit. Active sensors (0–10V) are in alarm when they value read is slightly above 10V.

To resolve the alarms, check the wiring to see if there is a loose wire or missing sensor.

## 9.1.5.5 Filter Alarms

NUMBER	NAME	STATUS SHOWN	MEANING
60	AI_OA_Flt_Press	Auto reset	OA Filter Pressure Alarm
61	AI_RA_Flt_Press	Auto reset	RA Filter Pressure Alarm

**Alarm Numbers 60–61:** Filter Alarms

These alarms occur when the pressure exceeds the OA Level or the RA Level as set in the *Alarm Settings*.

For more information refer to Pressure Drop Charts in the unit specific IOM.

```

ALARM SETTINGS
Filter Alarms
OA Level      1.0"w9
RA Level      1.0"w9
Alarm Delay   60 sec
  
```

To resolve the alarms, change the filter. If the alarm is still active, verify that the reading is as expected in the *Unit Status*. If not, check that someone has not changed the pressure transducer range in the *I/O Configuration*. Also check the offset or override for the sensors.

## 9.1.5.6 Maintenance Alarms

NUMBER	NAME	STATUS SHOWN	MEANING
62	AI_UnitLife	Auto reset	Unit Service Threshold Reached
64	AI_SupplyFanLife	Auto reset	Supply Fan Service Threshold Reached
65	AI_ExhaustFanLife	Auto reset	Exhaust Fan Service Threshold Reached

**Alarm Numbers 62–65:** Maintenance Alarms

These alarms occur when the number of run hours reaches the thresholds set in the *Advanced Service*. A typical screen is shown here.

```

ADVANCED SERVICE
UNIT SERVICE INFO
Run Hours:      0
Svc Thr:       200000hr
STATUS:OK
Reset Svc Hrs: NO
Starts:        0
Reset Starts:  NO
  
```

Refer to the *Advanced Service* for more information on these settings.

NUMBER	NAME	STATUS SHOWN	MEANING
68	AI_LowSupPress	User reset	Low Supply Pressure
69	AI_HighSupPress	User reset	High Supply Pressure
70	AI_LowExhPress	User reset	Low Exhaust Pressure
71	AI_HighExhPress	User reset	High Exhaust Pressure

## 9.2 TEST END DEVICES

The *Test End Devices* allows you to manually control outputs for testing. The unit must be off for this feature to be enabled. An alarm will occur in one hour (default) if you forget to take the device out of test mode.

Once done. Make sure you cycle power to end test mode and put all values back to zero.



### 9.2.1 Supply or Exhaust Fan Alarm Troubleshooting

These alarms, 10 and 11, mean that either the fan did not start or that the current switch did not detect that the fan is running. To troubleshoot this:

- Turn the unit off through the keypad.
- In the password protected menus, go to the *Test End Devices* and enable. As shown, an alarm will sound if you leave the unit in device test mode for more than an hour (default).



- Open both dampers.



- Enable both fans.



- For the fan that has the alarm (supply or exhaust), command the fan to run at 35% or so. If you see the flow increase but don't see the feedback (current switch) to yes, then the problem is with the current switch. If you don't see the flow increase the fan did not start and the problem is either with the wiring or the VFD parameters.

```

TEST END DEVICES
SUPPLY FAN COMMAND
TEST VALUE:

          35%
Feedback:  ON
Flow:     15888

```

- If you think the problem is with the current switch, try adjusting the fan % up until you see the feedback go to YES. During this time, you should also see the flow to continue to increase. Once you see the feedback turn to yes you know the current switch needs adjustment. If it gets to 100% and you do not see it turn to yes, it may be wiring or a bad current switch. You can try to adjust it below.

#### Adjusting the Current Switch

With the dampers open and the fans enabled as described in the Test End Devices mode above, set the fan for which you want to calibrate to the minimum speed (%) at which you expect it to operate.

On the top of the sensor, there are an adjusting screw and two LED lights, one red and one blue. The adjusting screw will turn 15 turns. To set the sensor for any fixed-speed fan:

- Verify that the blue LED is on.
- Slowly adjust the potentiometer screw clockwise until the RED LED just turns on. This sets the trip point at the normal operating load current
- If the RED LED is on after initial power-up, slowly adjust the potentiometer counter-clockwise until the BLUE LED turns on and then slowly adjust the potentiometer clockwise until the RED LED just turns on.

### IMPORTANT

Cycle power to the unit after you are done testing. This will take the unit out of Device Test Mode and reset all of the test values to off or 0%.

## 9.3 OTHER COMMON PROBLEMS

Listed are some other common problems you may encounter.

### 9.3.1 Unit Not On

If the unit will not run, go to this screen in *Unit Status* and the bottom line will tell you why.

Multiple items may be true. Possible messages and their meaning:

- Unit On: Unit is running
- Off by Alarm: A serious alarm is present; usually a fan alarm or supply temp alarm.
- Off by BMS: The BMS has set Enable BMS Control to yes and is not sending an On command.
- Off by DI: The orange DIN terminal must be connected to the black din terminal.
- Off by Keyboard: The menu screen *Unit On/Off* is set to off.
- Off by CO2 Level: the CO@ level is too low for the unit to run (special feature).
- Exhaust Fan Only Mode: The gray DIN terminal is connected to the black terminal indicating single fan mode. The setting for which fan will run is in *I/O Configuration*.
- Supply Fan Only Mode: The gray DIN terminal is connected to the black terminal indicating single fan mode. The setting for which fan will run is in *I/O Configuration*.
- BMS Cool Lockout: This means that *BMS Heat/Cool Mode?* Is set to Yes in *General Settings* and the current mode is heat.
- BMS Heat Lockout: This means that *BMS Heat/Cool Mode?* Is set to Yes in *General Settings* and the current mode is cool.
- In Device Test: Mode in *Test End Devices* is enabled. Cycle power to get it out of this mode.
- Input Overwritten: There is a sensor that is overwritten in Sensor Overrides. This occurs after 24 hours as a reminder.
- Unit Off by CO2 Level, Frost Control Active.



### 9.3.2 Sensor Reading #### or Has Extreme Value

This normally means that the sensor is not connected, or it has faulty wiring.

### 9.3.3 BMS Loss of Comm after Param Change or Restore

Most BMS setting changes require a power cycle. This applies to a parameter restore, which is basically the same thing.

### 9.3.4 Can Not See Device via IP Connection

If you are connected locally with a PC:

- Make sure your PC is on the same subnet but not the exact same IP address. The last octet has to differ.
- If you have just changed the IP address, make sure you said “update” on that screen and cycle power.
- Make sure the cable “snaps in” on both sides.
- Microsoft Edge browser does not work as well. Use Chrome, if possible.
- Make sure you don’t have anything in the USB connection in the front of the controller.

If you are connected remotely, check all of the above but also note that the connection has to be on the same subnet. An IP tunnel may also work.

## 9.4 TESTING FUNCTIONS IN GENERAL

When testing in general, the Sensor Overrides is a handy tool. These allow you to temporarily override a sensor to see if a function is working correctly. For example, if you want to test your cooling but it is cool outside, you can override your outdoor sensor to exceed the cool lockout temperature. This is handier than having to change all of your settings and then set them back.

To override a sensor, first set the value of the sensor and then enable. If you enable before setting the value, the value shown will be set right away. In this case, it will most likely turn on your heat.

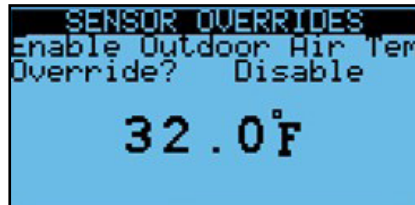

If you leave a sensor overwritten, an alarm will occur after 24 hours. All overwritten values are lost on power cycle and the statuses go back to disabled.

## 9.5 RESTORE PARAMETERS (SETTING)

There are several levels of settings in the controller. Some are set by the factory, and some are set by users. These parameters include all configuration settings, fan settings, heat/cool settings, and BMS settings.

### 9.5.1 User Commissioning Settings (Service)

At the end of the I/O Configuration, the user is prompted to save their settings. It is probably best to save these values after setting all of the values in the Control Variables as well. This is password protected as every time you save the settings, the file will overwrite. The file name is "SERVICE.txt," and it will be saved to either the internal memory location, or the external USB drive that is attached in front.

To perform this operation, the unit must be OFF.

- Choose the location: internal or USB
- Set Confirm to YES



**NOTE:** RenewAire highly recommends that a USB thumb drive be installed in the USB port and a system backup (external) be made immediately after start up or commissioning.



If you choose USB and you get "Cannot access disk," there is something wrong with the connection or disk.



If you do the operation correctly, it will say “Operation Done.”

```

I/O CONFIGURATION
Save User Settings
Note: Unit must be OFF
File name: SERVICE.txt
Location: INTERNAL
Confirm: YES
Operation done
  
```

To restore user settings, the screen is in Backup and Restore. The steps are:

- Choose the location: internal or USB
- Set Confirm to Yes

You should see “Operation done.”

```

BACKUP & RESTORE
Restore User Settings
Note: Unit must be OFF
File name: SERVICE.txt
Location: INTERNAL
Confirm: NO
  
```

If the unit does not confirm that the operation was done, the controller may have been older and upgraded in the field. Older version saved factory parameters in EXPORT\_76. See the *General Save and Restore* for information on how to get those settings back into the controller.

### 9.5.2 Restore Factory Settings

This operation is used to go back to factory settings that were set in the factory while they tested the unit. These are somewhat specific settings but going back to these settings will require you to perform start up and commissioning again. To return to factory defaults:

- Choose internal
- Set Confirm to YES

```

S BACKUP & RESTORE
Restore Factory
Note: Unit must be OFF
File name: FACTORY.txt
Location: INTERNAL
Confirm: NO
  
```

If the unit does not confirm that the operation was done, the controller may have been older and upgraded in the field. Older version saved factory parameters in EXPORT\_76. See the *General Save and Restore* for information on how to get those settings back into the controller.

### 9.5.3 General Save and Restore

There is a general save and restore function that allows you to save different versions of your parameters and save them under slightly different names.

Both saving and restoring use the same screen so care should be taken to make sure you have the screen set correctly so you do not lose all of your settings.

- Choose IMPORT (for restoring) or EXPORT (for saving)
- Choose memory type: INTERNAL or USB

- If the unit does not confirm that the operation was done, the controller may have been older and
- Choose File ID: EXPORT\_xx, where xx is any number from 00 to 99, If you are saving a set of parameters remember the number.
  - Set Confirm to YES

```

S  BACKUP & RESTORE
Params Import/Export
Import/Export:
EXPORT
Memory type:
INTERNAL FLASH MEMORY
File ID:      EXPORT_00
Confirm:     NO
    
```

9.5.4 Code List for Save and Restore

Use these codes to troubleshoot the Save and Restore Feature.

MESSAGE	MEANING
Operation Done	Save or Restore was successful.
Cannot Access Disk	This usually happens when you choose USB and the USB is not inserted or detected. If inserted, the connector may be too short.
Cannot access file	This usually happens when you are importing and the file you are importing does not exist.
Memory buffer is too small	You may have to erase some data from the drive or USB before you can perform the operation.
Time parameters are not correct	The clock needs to be set in <i>General Settings</i> .
Module is currently busy—retry is required	Another operation was running. Retry.
Log exporting failed	It is possible the connection was interrupted.
Input parameter value is not valid	The file may not be compatible with the program.

9.5.5 Return to Program Defaults

A more drastic approach may be needed to get internal settings out of the controller. Once done, you can restore a set of parameters by using any of the previously described methods. The process is called “Wipe Retain” for anyone familiar with the Carel controller. Most likely you will not use this operation unless you are directed to do so by RenewAire Technical Sales Support (TSS).

To perform this operation, choose YES on the top line Wipe retain mem.

```

ADVANCED SERVICE
DEFAULT INSTALLATION
Wipe retain mem.: NO
Wipe NURAM mem.: NO
Wipe both mem.: NO
    
```

The unit will take a minute to get back. Then you can resume entering your parameters by any method.

 NOTE: Do not use the other two lines unless directed to do so by TSS.

## 10.0 ACCESSING FILES FROM AND PERFORMING UPDATES TO THE CONTROLLER

The controller has a total of about 92 MB of internal memory. There are several types of files that use the internal 92 MB of mass storage that are available on the controller.

- Logs—exported automatically in the root
- Alarm List—exported on demand
- Parameter sets —see *Restore Parameters (Settings)*
- Program and OS Upgrade packages—Reside in an UPGRADE folder
- Web pages—Reside in an HTTP folder
- User storage, such as documents

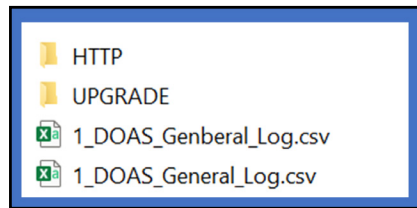

These files can be accessed through one of two methods:

- Connection via FTP through the Ethernet port
- Connection with a micro USB cable

It is also possible to export directly alarms, current log, and parameter sets to a USB drive that has either a micro USB connector or uses an adapter.

### 10.1 CONNECTIONS USING THE MICRO USB PORT

The controller has a built-in USB port where an external memory device such as a USB thumb drive can be plugged in. The external memory device may be used for backing up all settings and reported conditions such as Alarm History and presets. Backing-up is user-commanded and is done through the menu screens.

Note that the USB port is a Micro USB Type “B.” Thumb drives with a Micro USB Type B are difficult to find in some areas and it may be necessary to purchase an adapter to go from a more common Type A connector to the newer Micro Type B.

Make sure that the longer side of the USB connection is to the bottom of the controller. Do not force the connector in or you could damage the controller.

The controller requires that you use a cable or adapter with a longer end for the Micro USB side. One adapter we have found that works is the UGreen, purchased on Amazon.

 **NOTE:** You cannot be connected by both methods at the same time. If you are viewing the web pages and then connect with USB, the web page will go blank until you disconnect.

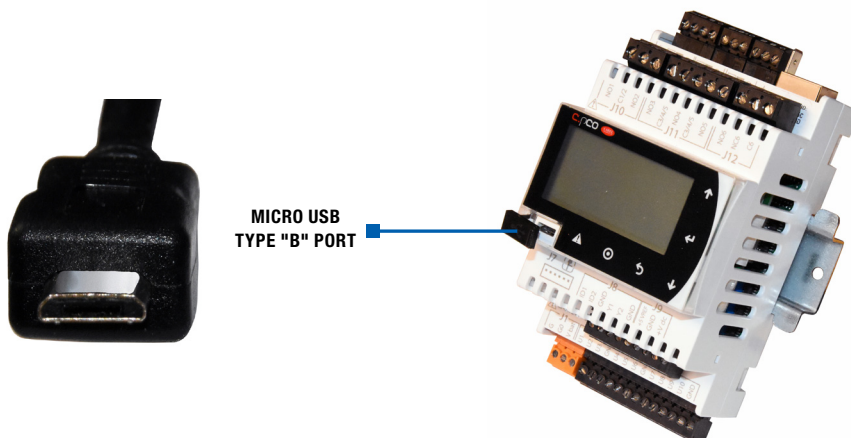

### 10.2 ALARMS AND DATA LOGS

Two types of files that are exported on demand are logs and alarm lists. They can be exported to the internal memory or the USB drive.

The export of the logs will show “In Process” while exporting. It may take a while depending upon the size.



#### 10.2.1 Example of Alarm Log

This is the file as opened in Excel. It includes a timestamp, alarm number, alarm name, and whether the event was the start of the alarm or the end (stop).

TIME	ID	NAME	EVENT	VAR1	VAR2
2022-01-28T16:11:22+00:00	39	AI_EA_Flow_Rate_Prbs.Active	Start		
2022-01-28T16:11:22+00:00	38	AI_OA_Flow_Rate_Prbs.Active	Start		
2022-01-28T16:11:21+00:00	42	AI_Supply_Temp_Prbs.Active	Start		
2022-01-27T17:48:22+00:00	39	AI_EA_Flow_Rate_Prbs.Active	Start		
2022-01-27T17:48:22+00:00	38	AI_OA_Flow_Rate_Prbs.Active	Start		
2022-01-27T17:48:20+00:00	42	AI_Supply_Temp_Prbs.Active	Start		
2022-01-27T15:48:02+00:00	39	AI_EA_Flow_Rate_Prbs.Active	Start		
2022-01-27T15:48:02+00:00	38	AI_OA_Flow_Rate_Prbs.Active	Start		

#### 10.2.2 Example of Data Log

This is the file as opened in Excel. It includes a timestamp and values of all of the factory preconfigured log values.

**NOTE:** There will be several log files on the internal drive. This is because the log is exported every night at midnight. The files are listed by day of week, where 1 = Monday. The file that starts with 9 is the file that is exported on demand.

TIME	EVENT	OA_Temp. Val	OA_Hum. Val	RA_Hum. Val	SA_Temp. Val	EA_Temp. Val	Cooling_C ommand.	Heating_C ommand.	RA_Temp. Val
2022-02-06T00:00:03+		22.079	23.14	20.73	20.111	21.768	0	0	22.134
2022-02-06T00:00:08+		22.079	23.14	20.74	20.134	21.756	0	0	22.134
2022-02-06T00:00:13+		22.079	23.13	20.69	20.154	21.756	0	0	22.134
2022-02-06T00:00:18+		22.067	23.15	20.71	20.166	21.756	0	0	22.134
2022-02-06T00:00:23+		22.067	23.15	20.725	20.166	21.756	0	0	22.123
2022-02-06T00:00:28+		22.067	23.14	20.695	20.178	21.756	0	0	22.123
2022-02-06T00:00:33+		22.067	23.14	20.71	20.189	21.756	0	0	22.123
2022-02-06T00:00:38+		22.067	23.14	20.705	20.199	21.745	0	0	22.123
2022-02-06T00:00:43+		22.067	23.14	20.69	20.209	21.745	0	0	22.123
2022-02-06T00:00:48+		22.067	23.14	20.735	20.209	21.745	0	0	22.123

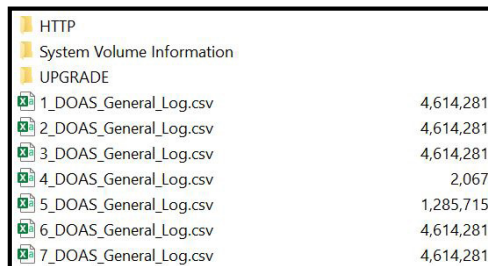

The variables that are logged are as listed here.

VARIABLE	VARIABLE	VARIABLE
OA_Temp.Val	Heating_Command.Val	Unit Status
OA_Hum.Val	RA_Temp.Val	CA_TEMP.VAL
RA_Hum.Val	OA_Enthalpy	OA+Flow_Rate
SA_Temp.Val	Bypass_Command.Val	EA_Flow_Rate
EA_Temp.Val	Any_Alarm_Out.Val	SF_Status
Cooling_Command.Val	Unit On	EF_Status

### 10.3 VIEWING PARAMETER FILES

You can view the parameter files that were created in *Restore Parameters (Settings)*. You can also share them between controllers. An excerpt of a file is shown below.

#Ver.1.0 cpCO Family Exported Configuration file

#VARIABLE	DESCRIPTION	DATA TYPE	DEFAULT VALUE
BACnet_Mapping	UINT		0
BMSMng.BACnetPort	UDINT		47808
BMSMng.BMS_Address_RS485	UINT		4
BMSMng.BMS_BACnetDeviceInstance	UDINT		5002
BMSMng.BMS_BACnetMSTP_MaxInfoFrames	UINT		20
BMSMng.BMS_BACnetMSTP_MaxMaster	UINT		127
BMSMng.BMS_BACnet_CmdTimeout	UINT		1500
BMSMng.BMS_BACnet_Timout	UINT		3000
BMSMng.BMS_Baud_Msk	UINT		2
BMSMng.BMS_Baud_RS485	UDINT		19200
BMSMng.BMS_Modbus_Timeout	UINT		3000
BMSMng.BMS_Parity_MSK	USINT		0

### 10.4 PERFORMING UPDATES TO THE CONTROLLER

If directed by TSS, you may need to perform an upgrade to the controller program. A very similar process is also used to field-install BACnet licenses into the controller. Refer to the BMS Access for that process.

There are three different methods to update a program, depending upon which way you connect to the controller. All three require that you have a file called "autorun.ap1," given to you by TSS.

1. Connect via USB. This requires that you have a micro USB cable to go from your PC to the controller micro USB connection and can see the files in Windows Explorer.
2. Connect with a USB thumb drive to the micro USB connection.
3. Connect via Ethernet. This requires a PC and the ability to connect to the embedded web pages inside the controller.

 **NOTE:** It is advised that you delete this file once you are done. Every upgrade file is named the same, regardless of version.

10.4.1 Upgrade Type: Connect via USB

1. Save the parameters using the *General Save and Restore* method. Make sure you choose EXPORT! Remember the Export\_XX number you chose.
2. Carefully connect the micro USB cable to the front connection of the controller (long side to the bottom) and to your PC. Verify that you can see the files in Windows Explorer. It shows up as a USB drive. If you cannot see these files you will need to use another method.

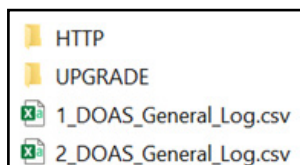

3. Put the autorun.ap1 file in the folder called "UPGRADE." You should not have other files in the root of that folder. You can have other folders in this folder, if needed.
4. You will be prompted to press "ENTER" to proceed.

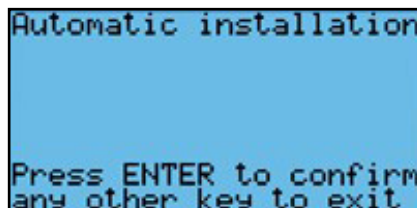

5. Once it is done you will be prompted to press "ENTER" to restart the controller.

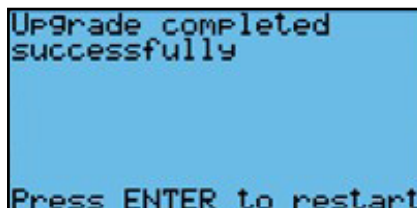

6. Restore the parameters using the *General Save and Restore* method. Make sure you choose IMPORT! Use the Export\_XX number you chose in step 1.
7. Cycle power.

10.4.2 Upgrade Type: Connect with a USB Thumb Drive

Connect with a USB thumb drive to the micro USB connection.

1. Save the parameters using the *General Save and Restore* method. Make sure you choose EXPORT! Remember the Export\_XX number you chose.
2. Put the autorun.ap1 file in a folder in the root of the thumb drive called "UPGRADE."
3. Carefully connect the micro USB drive to the front connection of the controller (long side to the bottom).
4. You will be prompted to press "ENTER" to proceed.

```
Automatic installation
Press ENTER to confirm
any other key to exit
```

5. Once it is done you will be prompted to press “ENTER” to restart the controller.

```
Upgrade completed
successfully
Press ENTER to restart
```

6. Restore the parameters using the *General Save and Restore* method. Make sure you choose IMPORT! Use the Export\_XX number you chose in step 1.

7. Cycle power.

#### 10.4.3 Upgrade Type: Connect via Ethernet

This requires a PC and the ability to connect to the embedded web pages inside the controller.

1. Save the parameters using the *General Save and Restore* method. Make sure you choose EXPORT! Remember the Export\_XX number you chose.

2. Go to the Upgrade Tab in the web pages.

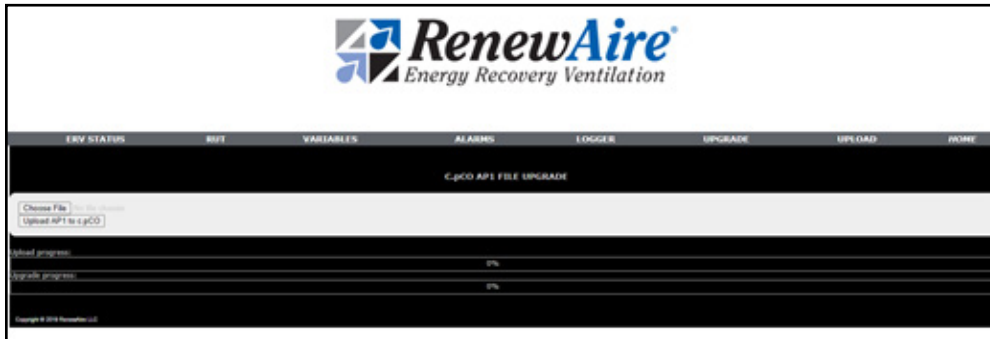

3. Click on “CHOOSE FILE” and locate the autorun.ap1 file on your PC that corresponds to the controller. Click “OPEN.” You should now see that file name next to “CHOOSE FILE.”

4. Click “Upload AP1 to c.pco.” You will see the file upload.

5. Once 100% on the upload, switch back to the RUT screen to see the upgrade taking place.

6. On the controller the program will see the file and require you to push “ENTER.” You can see that on the front of the controller itself or on the RUT page of the web pages.

7. Restore the parameters using the *General Save and Restore* method. Make sure you choose IMPORT! Use the Export\_XX number you chose in step 1.

8. Cycle power.

### 11.0 GENERAL SYSTEM MONITORING

This section describes the general system monitoring. It is here only to provide a general sense of how to monitor the system. Specific screens and information appear depending upon the features you have selected. Refer to the documentation on the specific function for the information on specific monitoring screens.

The unit is monitored through *Unit Status*.

#### 11.1 MAIN SCREEN

The main screen shows either the SA temperature coming off the core, or the CA temperature, depending upon whether the unit has tempering or not. It also shows the other four temperatures near the core.

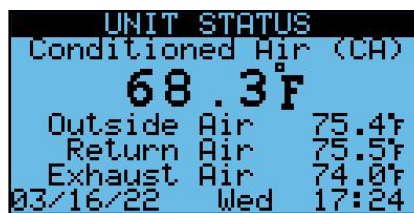

#### 11.2 OTHER STANDARD SCREENS

These screens also show standard values.

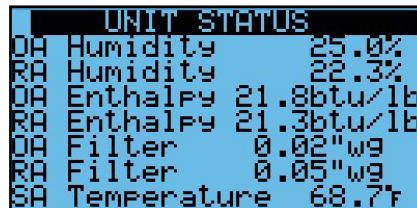

#### 11.3 FAN AND UNIT STATUS SCREENS

The first screen is helpful on starting the unit. It shows whether the fan is being asked to turn on (enabled), and whether the current sensor is detecting that it has turned on.

It also shows the *Unit Status* conditions, described in the chart below.

The seconds screen shows the speed of the fans.

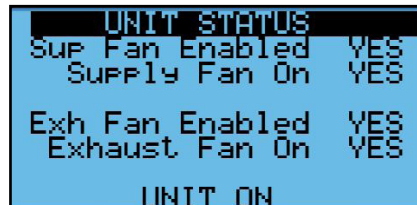

UNIT STATUS CONDITIONS	
STATUS SHOWN	MEANING
Unit on	The unit is on and running.
Off by alarm	The unit is off by a serious alarm.
Off by BMS	The unit is off by command from the BMS.
Off by Time Band	The unit is off by the scheduler.
Off by Schedule	The unit is off by the ID1 digital input.
Off by Keypad	The unit is off by the setting on the local interface.
EF Only Mode	The unit is in single fan mode with exhaust fan running.
SF Only Mode	The unit is in single fan mode with supply fan running.
BMS Cool Lockout	The unit is in HEAT mode from the BMS.
BMS Heat Lockout	The unit is in COOL mode from the BMS.
In Device Test	The system is in device test mode.
Input Overwritten	There is a sensor input that is overwritten.
Off by CO2 Level	The CO2 level is below the limit for running.
Flush Mode	The unit is running in FLUSH mode.
Frost Control on	The unit is running in Frost Control Mode.

The third screen shows:

- Whether the unit is enabled. (See *Unit Status Conditions* in the first screen to assess why the unit is not on).
- Whether the OA and RA dampers are open—they should be open if the unit is ON and in occupied mode, if applicable.
- The status of the bypass damper which is used for economizer and frost control, if the features are enabled.



### 11.4 FIELD-INSTALLED SENSOR SCREENS

If the CO2/VOC and/or duct pressure sensors were enabled and installed, their value and setpoint are shown here.

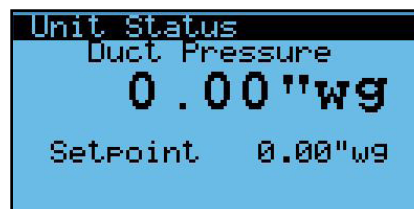

### 11.5 TEMPERING SCREENS

Depending upon whether heating or cooling are enabled for the unit, and depending upon which type is used, the screens here will vary.

#### 11.5.1 Heating Screens

Each screen tells

- Heating type in use
- Control Variable (unit supply or return air)
- Current Setpoint (or OA reset value)
- Status of outputs for that heat type
- Heating Status

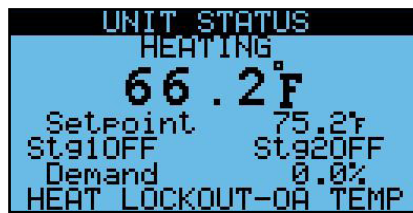

The heating status values are shown. Multiple values may be true.

MESSAGE	MEANING
Heat Locked Out by OA	The heating OA lockout is higher than the OA temperature.
Unit OFF	Unit is off.

#### 11.5.2 Cooling Screens

Each screen tells:

- Control Variable (unit supply or return air for cooling)
- Current Setpoint
- Status of outputs for that cooling type
- Cooling Status

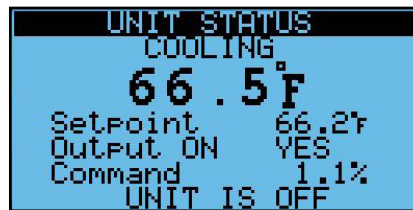

The cooling status values are shown. Multiple values may be true.

MESSAGE	MEANING
Cool Locked Out by OA	The cooling OA lockout is lower than the OA temperature.
Lockout Overlap	The OA lockouts for heating and cooling overlap. (No vent mode). The heating takes preference.
Econ Mode	If in economizer mode.
Unit OFF	Unit is off.

Screen showing economizer information, if enabled, including

- Cooling control value
- Cooling setpoint
- Whether economizer is active
- Cooling status

```

UNIT STATUS
Economizer
68.3F
Setpoint 66.2F
Active NO
Command 0.0%
UNIT IS OFF
  
```

## 11.6 FROST CONTROL INFORMATION

This screen contains all frost control information.

```

UNIT STATUS
FROST CONTROL
Active NO
EA Actual 58.7F
EA Setpoint On 25.0F
EA Setpoint Off 35.1F
DA Actual 50.7F
DA Setpoint 5.0F
  
```

## 11.7 ENTRY TO THE I/O INFORMATION SCREEN

This screen is described in *Verifying all I/O through Unit Status Screens*.

```

UNIT STATUS

Press ENTER for more
I/O Info
  
```

## 11.8 VERSION INFORMATION SCREEN

This screen contains:

- Type of application
- Version of program (SW) and operating system (OS)
- Unique controller identifier

```

UNIT STATUS

*RenewAire ERV*
Code:USRNAeERVN

SW ver.: 3.0.035
OS ver.: 0.0.000
000000000000000000
  
```

## 12.0 BMS ACCESS

The BMS settings are located in the *General Settings* after the scheduler. To get to that menu press the back button until it shows up.

### 12.1 SETTING CONTROL LEVEL

The first screen sets whether the unit will get an on/off command from the BMS. If you set this to Yes right away, the unit will not start until the BMS command is sent. Therefore, do not set this to Yes until you are ready to operate the unit.

Background: The unit will not turn on unless all of the following are true. As a result, any one can turn the unit off.

- There are no serious alarms.
- The Digital Input for start/stop (orange DIN terminal to black DIN terminal) are closed.
- The unit is turned on at the keypad.
- The time is within the scheduler "ON" time, if scheduler enabled.
- The BMS has written the unit on signal, if BMS control is enabled.

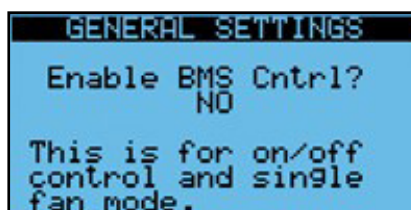

### 12.2 SETTING BMS TYPE

There are either three or five settings for BMS Type. The BACnet options will not show up unless a BACnet license has been installed.

- None
- BACnet MS/TP
- BACnet IP
- Modbus RTU
- Modbus IP



The license status can be viewed in a later screen. Refer to *Adding a BACnet License* for more information.

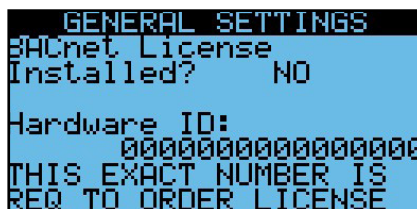

Once a protocol has been selected, additional BMS programming screens will appear. Change settings as needed. After the BMS protocol has been selected and protocol options have been selected, cycle power to the controller.

## 12.3 BACNET

RenewAire units Are BTL listed by CAREL. They allow the BMS to write to the present value by default. This means that if the BMS writes to a setpoint that setpoint can be changed by the local HMI display. (Last one in wins). Priority array is not supported.

Setpoints, in general, are saved in EEPROM memory and maintained on power loss. These are referred to as RETAINED. For retained values, DO NOT write to these values constantly. Doing so will flag an alarm and can damage the controller. If you have a need to write to a value constantly, contact TSS to discuss options.

Older units wrote to the priority array. This was cumbersome to support. They also had limited mapping. If upgrading from an older version and you want to keep that mapping, change the setting below to "Pri Array legacy." The mapping is quite different and is supported in the older documentation. Also note that priority array setpoints were not kept on power loss.

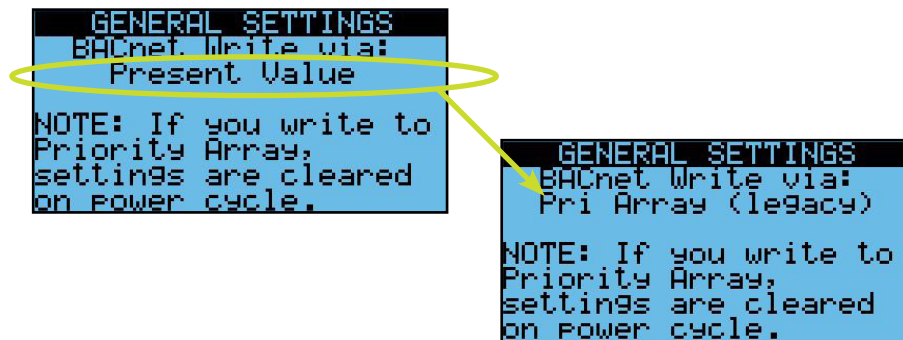

### 12.3.1 BACnet IP Connection

Connection of BACnet IP requires a physical cable connection to the RJ45 jack on the controller. Prior to making the wiring connections, the controller is to be tested to verify proper control of the unit under local control.

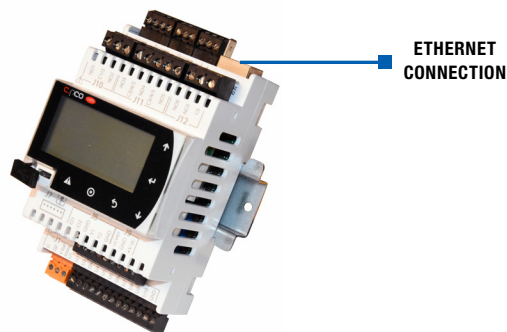

### 12.3.2 BACnet IP Settings

First, set the IP address of the controller in the same *General Settings* area.

- Set DHCP to Off if static.
- If Static, set the IP, mask, and gateway if required.
- *Set Update?* To Yes (power will need to be cycled. This can be done after all of the other settings.)

 NOTE: The controller will only support private IP addresses which start with 192, 172, or 10.

```

GENERAL SETTINGS
IP Address
DHCP: Off
IP: 10.10.1.2
MASK: 255.255.255.0
GW: 0.0.0.0
DNS: 0.0.0.0
Update? No
  
```

Next, set the BACnet Device ID. This screen allows you to set the ID digit by digit.

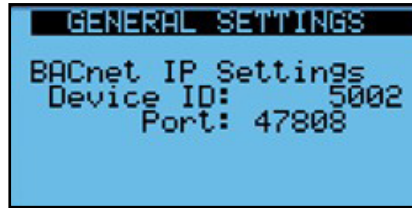

### 12.3.3 BACnet MSTP Settings

First, set the BACnet Device ID. This screen allows you to set the ID digit by digit.

 **NOTE:** Whenever the BMS type is changed, power to the controller must be cycled.

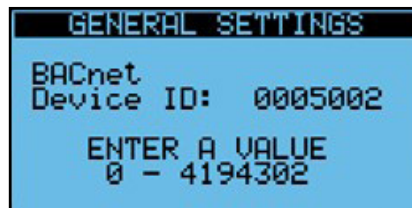

Next, set the BACnet MSTP Address, Baud rate, Max Master and Max Info frames as needed.

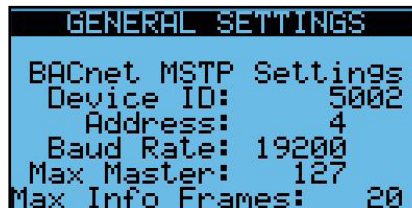

If you need to set the timing values, you can do that here.

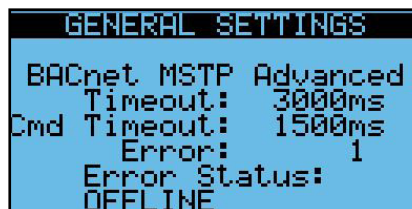

### 12.3.4 BACnet MSTP Wiring

The BACnet MSTP network is wired into the four-pin connector named J3 Disp. In the upper left-hand corner of the controller. This is also used for a RUT display so the two cannot be used at the same time. For MSTP, use the plus (+) and minus (-), as well as the GND for reference if desired.

**DO NOT** use the +Vterm terminal. If you happen to plus a three-pin block in here and use the wrong three pins you might damage the port.

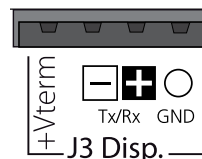

## 12.4 BACNET OBJECT LIST

TYPE	INSTANCE	VARIABLE NAME	DESCRIPTION	VALUE RANGE	READ/WRITE (RET)
Analog Input	0	OA_Temp.Val	OA Temperature	F	Read_NoWrite
Analog Input	1	OA_Hum.Val	OA Relative Humidity	%	Read_NoWrite
Analog Input	2	RA_Temp.Val	RA Temperature	F	Read_NoWrite
Analog Input	3	RA_Hum.Val	RA Relative Humidity	%	Read_NoWrite
Analog Input	4	EA_Temp.Val	EA Temperature	F	Read_NoWrite
Analog Input	5	SA_Temp.Val	SA Temperature (before tempering)	F	Read_NoWrite
Analog Input	6	OA_Flow_Rate.Val	OA Flow Rate	CFM	Read_NoWrite
Analog Input	7	EA_Flow_Rate.Val	EA Flow Rate	CFM	Read_NoWrite
Analog Input	8	Heating.HTG_SetP_Adjusted	Acting heating setpoint	F	Read_NoWrite
Analog Input	9	SA_Hum.Val	SA Relative Humidity	%	Read_NoWrite
Analog Input	10	EA_Hum.Val	EA Relative Humidity	%	Read_NoWrite
Analog Input	11	RA_Dewpoint	RA Dewpoint	F	Read_NoWrite
Analog Input	12	OA_Dewpoint	OA Dewpoint	F	Read_NoWrite
Analog Input	24	RA_Fit_Press.Val	RA Filter Pressure	iwc	Read_NoWrite
Analog Input	25	OA_Fit_Press.Val	OA Filter Pressure	iwc	Read_NoWrite
Analog Input	26	SF_Command.Val	Supply Fan Command (actual)	%	Read_NoWrite
Analog Input	27	EF_Command.Val	Exhaust Fan Command (actual)	%	Read_NoWrite
Analog Input	28	CO2_Level.Val	CO2 Level	PPM	Read_NoWrite
Analog Input	29	VOC_Level.Val	VOC Level	PPM	Read_NoWrite
Analog Input	30	Exhaust_DuctRoom_Press.Val	Exhaust Duct Space Pressure	iwc	Read_NoWrite
Analog Input	31	Supply_DuctRoom_Press.Val	Supply Duct Space Pressure	iwc	Read_NoWrite
Analog Input	32	CA_Temp.Val	CA Temperature (after tempering)	F	Read_NoWrite
Analog Input	33	Cooling_Command.Val	Cooling Command	%	Read_NoWrite
Analog Input	34	Cooling_LAT.Val	Cooling Coil Leaving Air Temperature (Used for dehumidification)	F	Read_NoWrite
Analog Input	36	CO2_Level_2nd.Val	CO2 Level , 2nd sensor	PPM	Read_NoWrite
Analog Input	37	Preheat_Command.Val	Command to preheater	0-100%	Read_NoWrite
Analog Input	38	CO2_Level_3rd.Val	CO2 Level , 3rd sensor	PPM	Read_NoWrite
Analog Input	39	CO2_Level_4th.Val	CO2 Level , 4th sensor	PPM	Read_NoWrite
Analog Input	59	Bypass_Command.Val	Command to modulating bypass	0-100%	Read_NoWrite
Analog Input	62	HGRH_Command.Val	Hot Gas Reheat Valve Command - Dehumification	F	Read_NoWrite

TYPE	INSTANCE	VARIABLE NAME	DESCRIPTION	VALUE RANGE	READ/WRITE (RET)
AnalogValue	32	HGRH_Coil_LAT_Setp.Val	Hot Gas Reheat Setpoint for conditioned air	F	Read_Writeable
Analog Value	34	Heating_Command.Val	Command to Heating output	%	Read_Writeable
Analog Value	35	RA_Flt_AlarmHigh	RA Filter Alarm Level	iwc	Read_Writeable (X)
Analog Value	36	OA_Flt_AlarmHigh	OA Filter Alarm Level	iwc	Read_Writeable (X)
Analog Value	37	SF_ConstSpeedSetP.Val	SF Const Speed Setpoint	%	Read_Writeable (X)
Analog Value	38	SF_FlowControlSetP.Val	SF Flow Control Setpoint	CFM	Read_Writeable (X)
Analog Value	39	SF_DuctStaticSetP.Val	SF Duct Static Pressure Setpoint	iwc	Read_Writeable (X)
Analog Value	40	SF_RoomStaticSetP.Val	SF Room Static Pressure Setpoint	iwc	Read_Writeable (X)
Analog Value	41	SF_CO2SetP.Val	SF CO2 Setpoint	PPM	Read_Writeable (X)
Analog Value	42	SF_VOCSetP.Val	SF VOC Setpoint	PPM	Read_Writeable (X)
Analog Value	43	EF_ConstSpeedSetP.Val	EF Constant Speed Setpoint	%	Read_Writeable (X)
Analog Value	44	EF_FlowControlSetP.Val	EF Flow Control Setpoint	CFM	Read_Writeable (X)
Analog Value	45	EF_SF_TrackingSetP.Val	EF SF Tracking Setpoint	%	Read_Writeable (X)
Analog Value	46	EF_ReturnStaticSetP.Val	EF Return Static Setpoint	iwc	Read_Writeable (X)
Analog Value	47	CoolLockoutTemp	OA Cooling Lockout Temperature	F	Read_Writeable (X)
Analog Value	48	HeatLockoutTemp	OA Heating Lockout Temperature	F	Read_Writeable (X)
Analog Value	50	Econ_Temp_Diff	Economizer Temperature Differential	F	Read_Writeable (X)
Analog Value	51	Economizer.Econ_Low_OA_Temp_Limit	Economizer Low OA Temp Limit	F	Read_Writeable (X)
Analog Value	52	Economizer.Econ_Hysteresis	Economizer Hysteresis	Btu/lb	Read_Writeable (X)
Analog Value	53	BMS_CO2_Reading	BMS CO2 Reading (in lieu of attached sensor)	PPM	Read_Writeable
Analog Value	54	BMS_Space_Press_Reading	Coil LAT Setpoint for dehumidification	F	Read_Writeable (X)
Analog Value	55	Occ_HTG_Setp.Val	Occupied Heating Setpoint	F	Read_Writeable (X)
Analog Value	56	Occ_CLG_Setp.Val	Occupied Cooling Setpoint	F	Read_Writeable (X)
AnalogValue	57	HGRH_Unit_LAT_Setp.Val	Setpoint for reheated conditioned air during dehumidification	F	Read_Writeable
Analog Value	58	Economizer.Econ_Low_RA_Temp_Limit	Economizer.Econ_Low_RA_Temp_Limit	F	Read_Writeable (X)
Analog Value	59	SF_CO2FlowMinCO2.Val	SF Flow: MinCO2	PPM	Read_Writeable (X)
Analog Value	60	SF_CO2FlowMaxCO2.Val	SF Flow: Max CO2	PPM	Read_Writeable (X)
Analog Value	61	SF_CO2FlowMinFlow.Val	SF Flow: Min Flow	CFM	Read_Writeable (X)
Analog Value	62	SF_CO2FlowMaxFlow.Val	SF Flow: Max Flow	CFM	Read_Writeable (X)
AnalogValue	64	SF_UnoccFlowSetP.Val	Flow setpoint for unoccupied operation (Set high enough to trigger current switch)	CFM	Read_Writeable
AnalogValue	66	Unocc_CLG_Setp.Val	Unoccupied cooling setpoint	F	Read_Writeable
AnalogValue	71	Unocc_HTG_Setp.Val	Unoccupied heating setpoint	F	Read_Writeable
AnalogValue	73	Dehumid_Changeover_Setp.Val	Dewpoint value where dehumidification is engaged	F	Read_Writeable

TYPE	INSTANCE	VARIABLE NAME	DESCRIPTION	VALUE RANGE	READ/WRITE (RET)
Analog Value	77	Defrost_OA_SetP.Val	Frost control OA Setpoint Low Limit	F	Read_Writeable (X)
Analog Value	78	Defrost_EA_Low_SetP.Val	Frost control EA Setpoint Low Limit	F	Read_Writeable (X)
Analog Value	79	Defrost_EA_High_SetP.Val	Frost control EA High Limit Setpoint	F	Read_Writeable (X)
AnalogValue	80	BMS_SupplyFanCommand	Command used when BMS commands fans directly every cycle	%	Read_Writeable
AnalogValue	81	BMS_ExhaustFanCommand	Command used when BMS commands fans directly every cycle	%	Read_Writeable
AnalogValue	82	EF_Tracking_SFMode	Fan speed to run EF when it is in EF only mode and it is tracking Supply Fan	%	Read_Writeable
AnalogValue	90	SF_ConstSpeedSetP_Boost.val	SF Constant Speed Setpoint in Boost Mode	%	Read_Writeable
AnalogValue	91	EF_ConstSpeedSetP_Boost.val	EF Constant Speed Setpoint in Boost Mode	%	Read_Writeable
AnalogValue	92	SF_FlowControlSetP_Boost	SF Control Setpoint in Boost Mode	cfm	Read_Writeable
AnalogValue	93	EF_FlowControlSetP_Boost	EF Flow Control Setpoint in Boost Mode	cfm	Read_Writeable
AnalogValue	94	PreheatLowLimit	Preheater low limit setpoint for outdoor air	F	Read_Writeable (X)
AnalogValue	500	OA_Fit_AlarmHigh	OA Filter Alarm Level	iwc	Read_Writeable
AnalogValue	501	RA_Fit_AlarmHigh	RA Filter Alarm Level	iwc	Read_Writeable
AnalogValue	502	CO2_AlarmHigh	Alarm level for CO2	PPM	Read_Writeable
AnalogValue	503	VOC_AlarmHigh	Alarm level for VOC	PPM	Read_Writeable
AnalogValue	504	SF_FlowControlTol	Supply Fan Flow Control Tolerance	0-110% (>100% disables)	Read_Writeable
AnalogValue	505	EF_FlowControlTol	Exhaust Fan Flow Control Tolerance	0-110% (>100% disables)	Read_Writeable
AnalogValue	506	SF_DuctStaticTol	Supply Fan Duct Static Pressure Tolerance	0-110% (>100% disables)	Read_Writeable
AnalogValue	507	SF_RoomStaticTol	Supply Fan Room Static Pressure Tolerance	0-110% (>100% disables)	Read_Writeable
AnalogValue	508	EF_RoomStaticTol	Exhaust Fan Room Static Pressure Tolerance	0-110% (> 100% disables)	Read_Writeable
AnalogValue	509	Low_SupAir_Temp_Warn_SetP.Val	Low temperature level for Supply Temp Warning	F	Read_Writeable
AnalogValue	510	Low_SupAir_Temp_Alm_SetP.Val	Low temperature level for Supply Temp Alarm - shuts unit down	F	Read_Writeable
AnalogValue	511	High_SupAir_Temp_Warn_SetP.Val	High temperature level for Supply Temp Warning	F	Read_Writeable(X)
AnalogValue	512	High_SupAir_Temp_Alm_SetP.Val	High temperature level for Supply Temp Alarm - shuts unit down	F	Read_Writeable(X)
Binary Input	8	OA_Damp.Val	OA Damper Command	Closed/ Open	Read_NoWrite
Binary Input	9	RA_Damp.Val	RA Damper Command	Closed/ Open	Read_NoWrite
Binary Input	13	Tempering_Mode.Val	Tempering Mode	Heat/Cool	Read_NoWrite
Binary Input	14	AlarmMng.AlmRes	Alarm Reset Status	No/Yes	Read_NoWrite
Binary Input	15	SF_Status.Val	SF Status from Current Sensor	Off/On	Read_NoWrite

TYPE	INSTANCE	VARIABLE NAME	DESCRIPTION	VALUE RANGE	READ/WRITE (RET)
Binary Input	16	EF_Status.Val	EF Status from Current Sensor	Off/On	Read_NoWrite
Binary Input	17	Alarm_Out.Val	Serious Alarm (Also a physical output)	OK/Alarm	Read_NoWrite
Binary Input	18	Heating_Enable_1.Val	Heating Stage 1	Off/On	Read_NoWrite
Binary Input	19	Cooling_Stage_1.Val	Cooling Stage 1	Off/On	Read_NoWrite
Binary Input	20	Cooling_Stage_2.Val	Cooling Stage 2	Off/On	Read_NoWrite
Binary Input	21	UnitOn	Unit On Status	Off/On	Read_NoWrite
Binary Input	22	AI_SupplyFan.Active	Supply Fan Start Alarm	OK/Alarm	Read_NoWrite
Binary Input	23	AI_ExhaustFan.Active	Exhaust Fan Start Alarm	OK/Alarm	Read_NoWrite
Binary Input	49	Bypass_Damper.Val	Bypass Damper Command	Close/Open	Read_NoWrite
Binary Input	50	OfflineAlarm_CPCOE_1.Active	Expansion Module is offline	OK/Alarm	Read_NoWrite
Binary Input	57	Heating_Enable_2.Val	Heating Stage 2	Off/On	Read_NoWrite
Binary Input	61	DehumidMode_On	Unit is in dehumidification mode	Off/On	Read_NoWrite
Binary Input	64	HGRH_2Pos.Val	Output to two-position HGRH valve	Off/on	Read_NoWrite
Binary Input	71	UnitOffByDefrost	Unit is off by VRF Defrost Mode	No/Yes	Read_NoWrite
Binary Input	72	Any_Alarm_Out.Val	Any Alarm is True Status	OK/Alarm	Read_NoWrite
Binary Input	73	BoostMode.Val	Boost Mode value	Normal/Boost	Read_NoWrite
Binary Input	76	BMS_Enable	Tells whether BMS control is enabled for on/off, unocc, single fan	Off/on	Read_NoWrite
Binary Input	500	AI_retain.Active	Too Many Writes to Retained Memory	OK/Alarm	Read_NoWrite
Binary Input	501	AI_Err_retain_write.Active	Too Many Writes to Retained Memory	OK/Alarm	Read_NoWrite
Binary Input	502	AI_Device_Test.Active	Unit Was Left In Device Test Mode	OK/Alarm	Read_NoWrite
Binary Input	503	AI_BMS_Offline.Active	BMS is Offline	OK/Alarm	Read_NoWrite
Binary Input	504	OfflineAlarm_CPCOE_1.Active	Offline Alarm Expansion Module	OK/Alarm	Read_NoWrite
Binary Input	505	CfgErrAlarm_CPCOE_1.Active	Expansion Module Config Error	OK/Alarm	Read_NoWrite
Binary Input	508	AI_Smoke.Active	Smoke Alarm Input Engaged	OK/Alarm	Read_NoWrite
Binary Input	509	AI_Freeze.Active	Freezestat Alarm Input Engaged	OK/Alarm	Read_NoWrite
Binary Input	510	AI_SupplyFan.Active	Supply Fan Start Alarm	OK/Alarm	Read_NoWrite
Binary Input	511	AI_ExhaustFan.Active	Exhaust Fan Start Alarm	OK/Alarm	Read_NoWrite
Binary Input	512	AI_SA_Airflow.Active	Supply Airflow Out of Tolerance Alarm	OK/Alarm	Read_NoWrite
Binary Input	513	AI_EA_Airflow.Active	Exhaust Airflow Out of Tolerance Alarm	OK/Alarm	Read_NoWrite
Binary Input	514	AI_SA_PressTol.Active	SA Static Pressure Level Alarm	OK/Alarm	Read_NoWrite
Binary Input	515	AI_CO2.Active	CO2 Level Alarm	OK/Alarm	Read_NoWrite
Binary Input	516	AI_SupAir_Low_Temp_Warn.Active	Supply Air Low Temperature Warning	OK/Alarm	Read_NoWrite
Binary Input	517	AI_SupAir_Low_Temp_Alarm.Active	Supply Air Low Temperature Alarm	OK/Alarm	Read_NoWrite

TYPE	INSTANCE	VARIABLE NAME	DESCRIPTION	VALUE RANGE	READ/WRITE (RET)
Binary Input	518	Al_SupAir_Hi_Temp_Warn.Active	Supply Air High Temperature Warning	OK/Alarm	Read_NoWrite
Binary Input	519	Al_SupAir_Hi_Temp_Alarm.Active	Supply Air High Temperature Alarm	OK/Alarm	Read_NoWrite
Binary Input	520	Al_VOC.Active	VOC level is above limit	OK/Alarm	Read_NoWrite
Binary Input	521	Al_EA_PressTol.Active	EA Static Pressure Level Alarm	OK/Alarm	Read_NoWrite
Binary Input	522	Al_H2OLeak.Active	Water leak has been detected	OK/Alarm	Read_NoWrite
Binary Input	523	Al_SmokePurge.Active	Smoke purge has been activated	OK/Alarm	Read_NoWrite
Binary Input	524	Al_VRV_Alarm	VRV System Alarm	OK/Alarm	Read_NoWrite
Binary Input	525	Al_RefLeakDetected	Refrigerant Leak Detected	OK/Alarm	Read_NoWrite
Binary Input	526	Al_RefLeakDetected_Man	Refrigerant Leak Detected—Man Reset	OK/Alarm	Read_NoWrite
Binary Input	527	Al_RefLeakDetected_Until	Refrigerant Leak Detected—Mult Occur	OK/Alarm	Read_NoWrite
Binary Input	528	Al_SA_Hum_Prpb.Active	Supply Air Humidity Sensor is faulty	OK/Alarm	Read_NoWrite
Binary Input	529	Al_EA_Hum_Prpb.Active	Exhaust Air Humidity Sensor is faulty	OK/Alarm	Read_NoWrite
Binary Input	530	Al_OA_Temp_Prpb.Active	OA Temperature Sensor Open or Short	OK/Alarm	Read_NoWrite
Binary Input	531	Al_OA_Hum_Prpb.Active	OA Relative Humidity Transmitter Out of Range	OK/Alarm	Read_NoWrite
Binary Input	532	Al_RA_Temp_Prpb.Active	RA Temperature Sensor Open or Short	OK/Alarm	Read_NoWrite
Binary Input	533	Al_RA_Hum_Prpb.Active	RA Relative Humidity Transmitter Out of Range	OK/Alarm	Read_NoWrite
Binary Input	534	Al_SA_Temp_Prpb.Active	SA Temperature Sensor Open or Short	OK/Alarm	Read_NoWrite
Binary Input	535	Al_EA_Temp_Prpb.Active	EA Temperature Sensor Open or Short	OK/Alarm	Read_NoWrite
Binary Input	536	Al_OA_Flt_Press_Prpb.Active	OA Filter Pressure Transmitter Out of Range	OK/Alarm	Read_NoWrite
Binary Input	537	Al_RA_Flt_Press_Prpb.Active	RA Filter Pressure Transmitter Out of Range	OK/Alarm	Read_NoWrite
Binary Input	538	Al_OA_Flow_Rate_Prpb.Active	OA Flow Rate Pressure Transmitter Out of Range	OK/Alarm	Read_NoWrite
Binary Input	539	Al_EA_Flow_Rate_Prpb.Active	EA Flow Rate Pressure Transmitter Out of Range	OK/Alarm	Read_NoWrite
Binary Input	540	Al_CO2_Level_Prpb.Active	CO2 Level Transmitter Out of Range	OK/Alarm	Read_NoWrite
Binary Input	541	Al_Duct_Press_Prpb.Active	Duct Pressure Transmitter Out of Range	OK/Alarm	Read_NoWrite
Binary Input	542	Al_Supply_Temp_Prpb.Active	Conditioned Air (CA) Temperature Sensor Open or Short	OK/Alarm	Read_NoWrite
Binary Input	543	Al_Coil_LAT_Prpb.Active	Coil leaving Temp Sensor is faulty	OK/Alarm	Read_NoWrite
Binary Input	544	Al_VOC_Level_Prpb.Active	VOC Probe Alarm	OK/Alarm	Read_NoWrite
Binary Input	545	Al_Space_Press_Prpb.Active	Space Pressure Probe Alarm	OK/Alarm	Read_NoWrite
Binary Input	546	Al_CO2_2_Prpb.Active	2nd CO2 sensor is faulty	OK/Alarm	Read_NoWrite
Binary Input	548	Al_CO2_2_Prpb.Active	3rd CO2 sensor is faulty	OK/Alarm	Read_NoWrite
Binary Input	549	Al_CO2_3_Prpb.Active	4th CO2 sensor is faulty	OK/Alarm	Read_NoWrite
Binary Input	560	Al_RA_Flt_Press.Active	RA Filter Needs Change	OK/Alarm	Read_NoWrite

TYPE	INSTANCE	VARIABLE NAME	DESCRIPTION	VALUE RANGE	READ/WRITE (RET)
Binary Input	561	AI_OA_Flt_Press.Active	OA Filter Needs Change	OK/Alarm	Read_NoWrite
Binary Input	562	AI_UnitLife.Active	Unit Service Request	OK/Alarm	Read_NoWrite
Binary Input	564	AI_SupplyFanLife.Active	Supply Fan Service Request	OK/Alarm	Read_NoWrite
Binary Input	565	AI_ExhaustFanLife.Active	Exhaust Fan Service Request	OK/Alarm	Read_NoWrite
Binary Value	566	AI_CoolStage1Life	Compressor 1 Service Threshold Reached	OK/Alarm	Read_NoWrite
Binary Value	567	AI_CoolStage2Life	Compressor 2 Service Threshold Reached	OK/Alarm	Read_NoWrite
Binary Value	568	AI_LowSupPress	Low pressure limit supply fan	OK/Alarm	Read_NoWrite
Binary Value	569	AI_HighSupPress	High pressure limit supply fan	OK/Alarm	Read_NoWrite
Binary Value	570	AI_LowExhPress	Low pressure limit exhaust fan	OK/Alarm	Read_NoWrite
Binary Value	571	AI_HighExhPress	High pressure limit exhaust fan	OK/Alarm	Read_NoWrite
Binary Value	10	OnOffUnitMng.BmsOnOff	BMS On/Off Command	Off/On	Read_Writeable
Binary Value	11	OnOffUnitMng.BmsEfOnly	BMS Exhaust Fan Only Command		
Binary Value	12	AlarmMng.AlrmResByBms	Alarm Reset BMS Command	OK/Reset	Read_Writeable
Binary Value	13	One_Fan_Mode	When single fan mode is engaged, this is the fan that will run	Exhaust Fan/Supply Fan	Read_Writeable
Binary Value	60	BMS_SetHeatCool	BMS Set Heat/Cool Capability	No/Allow	Read_Writeable (X)
Binary Value	61	BMS_HeatCoolMode	BMS Heat/Cool Mode Setting	Heat/Cool	Read_Writeable (X)
Binary Value	63	BmsUnocc	BMS command to unoccupied mode (unit should be ON)	No/Yes	Read_Writeable
Binary Value	74	BMS_HW_Valve_Control	BMS HW Valve Control	No/Allow	Read_Writeable
Binary Value	75	Heating_Enable_1.Val	Heating Stage 1 BMS Enable	Off/On	Read_Writeable
Binary Value	524	AI_VRV_Alarm.Trigger	VRV Alarm is set to fault from VRV system	OK/Alarm	Read_Writeable(X)
MultiState Input	2	SF_ControlType_BN	SF_ControlType_BN	(See Notes)	Read_NoWrite
MultiState Input	3	EF_ControlType_BN	EF_ControlType_BN	(See Notes)	Read_NoWrite
MultiState Input	4	HTG_ControlType_BN	HTG_ControlType_BN	(See Notes)	Read_NoWrite
MultiState Input	5	CLG_ControlType_BN	CLG_ControlType_BN	(See Notes)	Read_NoWrite
MultiState Input	6	Heating_SetPtType_BN	Heating_SetPtType_BN	(See Notes)	Read_NoWrite
MultiState Input	7	UnitStatus_BN	UnitStatus_BN	(See Notes)	Read_NoWrite
MultiState Input	8	Cooling_SetPtType_BN	Cooling_SetPtType_BN	(See Notes)	Read_NoWrite

## 12.5 BACNET APPLICATION NOTES

### 12.5.1 Turning the Unit On and Off

If you plan to use the BMS to turn the unit on and off, make sure you have the control enabled through the keypad. Use Binary Value 10 “OnOffUnitMng.BmsOnOff.” The status can be read at “UnitOn” at Binary Input 21.

All of the following have to be true in order for the unit to be on:

- There are no serious alarms.
- The Digital Input for start/stop (orange DIN terminal to black DIN terminal) are closed.
- The unit is turned on at the keypad.
- The time is within the scheduler “ON” time, if scheduler enabled.
- The BMS has written the unit on signal, if BMS control is enabled

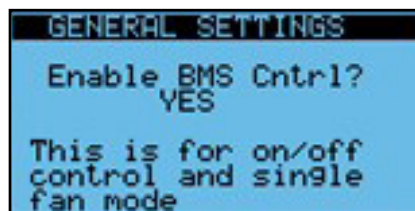

UNITSTATUS_BN: MULTISTATE INPUT 7		
VALUE	STATUS	MEANING
1	Unit on	The unit is on and running.
2	Unit switched off due to alarm	The unit is off by a serious alarm.
3	Unit switched off by BMS	The unit is off by command from the BMS.
4	Unit switched off by time band	The unit is off by the scheduler.
5	Unit switched off by digital input	The unit is off due to the ID1 input not being connected to COM.
6	Unit switched off from the local keypad	The unit is off by the setting on the menu screen.
8	Exhaust Fan Only Mode	The unit is in single fan mode with exhaust fan running.
9	Supply Fan Only Mode	The unit is in single fan mode with supply fan running.
11	Cool Locked Out by BMS	A BMS command has the cooling locked out.
12	Heat Locked Out by BMS	A BMS command has the heating locked out.
13	Device Test	The system is in device test mode for more than an hour.
14	Sens Ovrdr Active	The system has a sensor overwritten for more than 24 hours.
15	Off by CO2 Level	Off by CO2 Level.
16	Frost Control On	Frost Control Mode Active.

### 12.5.2 Alarms

Individual alarms are mapped to Binary Inputs 500 and above. Two general alarms are available:

- Serious Alarm: Located at Binary Input 17, “Alarm\_Out.val” indicates whether there is a serious alarm that stops the unit.
- Any Alarm: Located at Binary Input 72, “Any\_Alarm\_Out.val” indicates whether there is any alarm present.

To reset the User Reset type alarms, set Binary Value 12 “AlarmMng.AlrmResByBMS” to true. The program will set it back to false. You can view the status change through Binary Input 14 “AlarmMng.AlrmRes.”

### 12.5.3 Temperature and Humidity Around the ERV

The following are available:

- Analog Input 0 “OA\_Temp.Val”
- Analog Input 1 “OA\_Hum.Val”
- Analog Input 2 “RA\_Temp.Val”
- Analog Input 3 “RA\_Hum.Val”
- Analog Input 4 “EA\_Temp.Val”
- Analog Input 5 “SA\_Temp.Val”

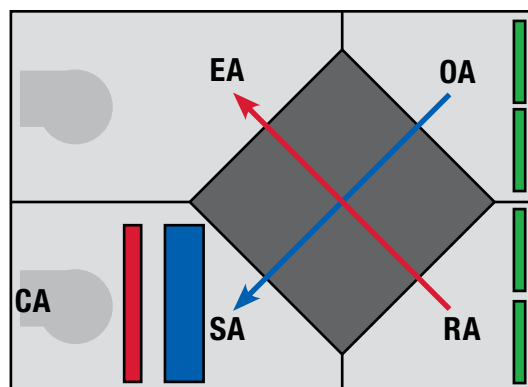

### 12.5.4 Fan Control

The supply fan control type method can be viewed at Multistate Input 2 “SF\_ControlType\_BN.” The valid values are 0 = Constant Speed, 1 = Supply Airflow, 2 = Duct Static Pressure, 3 = Room Static Pressure, 4 = CO2, 5 = VOC, 6 = CO2 Flow.

The corresponding settings are as follows:

- Constant Speed setpoint is Analog Value 37 “SF\_ConstantSpeedSetP.Val”
- Supply Airflow setpoint is Analog Value 38 “SF\_FlowControlSetP.Val”
- Room Static Setpoint is Analog Value 40 “SF\_RoomStaticSetP.Val”
- Duct Static setpoint is Analog Value 39 “SF\_DuctStaticSetP.Val”
- CO2/VOC setpoint is Analog Value 41 “SF\_CO2\_SetP.Val” or Analog Value 42 “SF\_VOCSetP.Val”
- CO2 Flow ramp set at Analog Values 59, 60, 61, and 62

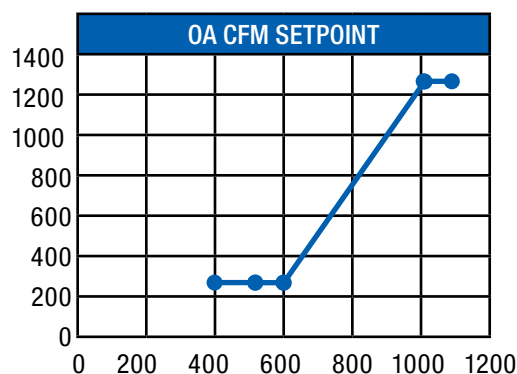

The command to the fan is read at Analog Input 26 "SF\_Command.Val." The feedback from the current sensor is read at Binary Input 15 "SF\_Status.Val." The actual flow rate is viewed at Analog input 6 "OA\_Flow\_Rate.Val."

The exhaust fan control type method can be viewed at Multistate Input 3 "EF\_ControlType\_BN." The valid values are 1 = Constant Speed, 2 = Exhaust Airflow, 3 = SF Command Tracking, 4 = SF Flow Tracking, 5 = Return Static Pressure.

The corresponding settings are as follows:

- Constant Speed setpoint is Analog Value 43 "EF\_ConstantSpeedSetP.Val"
- Exhaust Airflow setpoint is Analog Value 44 "EF\_FlowControlSetP.Val"
- Exhaust Fan Tracking setpoint is Analog Value 45 "EF\_SF\_TrackingSetP.Val"
- Return Static setpoint is Analog Value 46 "EF\_ReturnStaticSetP.Val"

The command to the fan is read at Analog Input 27 "EF\_Command.Val." The feedback from the current sensor is read at Binary Input 16 "EF\_Status.Val." The actual flow rate is viewed at Analog input 7 "EA\_Flow\_Rate.Val."

### 12.5.5 BMS Direct Fan Control

Available in ERV versions 03\_00\_26 ERV and higher.

Normally we use the setpoints below for constant speed fan control. These are retained variables that are kept on power loss and should not be written to constantly. You will get an alarm error and/or damage the controller by doing so.

Normal setpoint objects for constant speed fan control:

- SF\_ConstSpeedSetP.Val AV37
- EF\_ConstSpeedSetP.Val AV43

The newer versions allow a BMS system to command directly to the speed control with a non-retained variable. This is done with systems where the BMS is writing to the value every program cycle. One example would be when they use their own pressure control loop and only write the output to the fan.

The fan settings for supply and exhaust fan are independent. The user must set the control for that fan to constant speed control.

The objects used for reading the fan control type are:

- SF\_ControlType\_BN MI2
- EF\_ControlType\_BN MI3

They must be set on these screens.



In order to use this feature, the settings must be set in this screen, located in the General Settings near the other BMS settings. The user must set the corresponding fan to "YES."

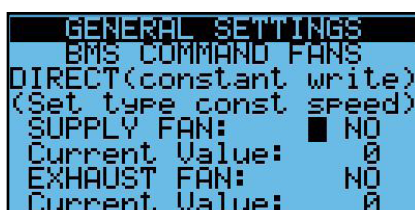

The objects used for direct writing the percentages are:

- BMS\_SupplyFanCommand AV80 expressed as 0-100%
- BMS\_ExhaustFanCommand AV81 expressed as 0-100%

In the screen above you will be able to see the value of these objects under “Current Value” for troubleshooting purposes.

The Control Setting Screen will no longer be available. Instead, the following screen(s) will be shown accordingly, with the current command shown being read-only on the screen.



#### 12.5.6 Tempering Control

The ERV unit may provide heating and cooling/if ordered as such. For heating and/or cooling, there will be a conditioned air temperature sensor which measured the air coming out of the unit as Analog Input 32 “CA\_Temp.Val.”

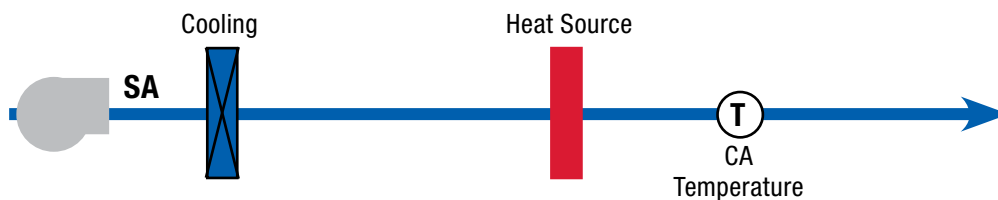

##### 12.5.6.1 Determining Tempering Mode

To determine the mode in which the unit is operating, the following values are considered:

- Analog Value 48 “HeatLockoutTemp”
- Analog Value 47 “CoolLockoutTemp”

In addition, the BMS has the potential to use one more setting to determine whether the unit will lock out heating or cooling functions. This is required for the dual temp systems and may be useful for other situations. The Binary Value 60 “BMS\_SetHeatCool” must be true and then the mode is set through Binary Value 61 “BMS\_HeatCoolMode” where 0 =Heat and 1 = Cool. The BMS mode is shown for troubleshooting.

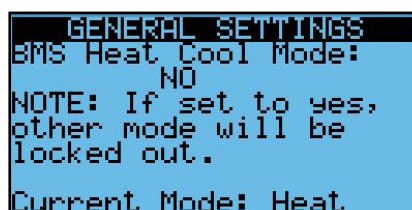

The current Tempering Mode is viewed at Binary Input 13 “Tempering\_Mode.Val.” It is also an output used for VRF applications. The tempering mode will show heating when in heating or ventilation only mode, and cooling.

### 12.5.6.2 Heating Control

The heating control type is located at Multistate Input 4 “HTG\_ControlType\_BN.” The setpoint is Analog Value 55 “Occ\_HTG\_SetP.Val” if adjustable setpoint is chosen. Otherwise the setpoint is based on an outdoor temperature schedule. The type is Multistate Input 6 “Heating\_SetPtType\_BN,” where 1 = Adjust and 2 = OA Reset. The acting setpoint is Analog Input 8 “HTG\_SetP\_Adjusted.”

The heating output statuses are the following:

- Binary Input 18 “Heating\_Enable\_1.Val” for stage one or modulating types where the demand is greater than 0
- Binary Input 57 “Heating\_Enable\_2.Val” for stage two
- Analog Input 34 “Heating\_Command.Val” shows a percentage for the 0–10V output.

It is also possible for the BMS to take over total control of the 10–0V hot water valve signal out to the controlled valve and heating output directly for special cases. All setpoints, etc. will be ignored in this case. To do this, set the heating setting “Valve Control” to BMS on the screen, or through Binary Value 74 “BMS\_HW\_Valve\_Control.”



Then control the valve through

- Analog Value 34 “HeatingCommand\_BMS” to set a value for the 0–10V output, where 0 is 0V and 100 is 10V.
- Binary Value 75 “Heating\_Enable\_1.Val” can also be controlled directly if needed.

### 12.5.6.3 Cooling Control

The cooling control type is located at Multistate Input 5 “CLG\_ControlType\_BN.” The setpoint is Analog Value 56 “Occ\_CLG\_SetP.Val.”

The cooling output statuses are the following:

- Binary Input 19 “Cooling\_Enable\_1.Val” for stage one or modulating types where the demand is greater than 0
- Binary Input 20 “Cooling\_Enable\_2.Val” for stage two
- Analog Input 33 “Cooling\_Command.Val” shows a percentage for the 0–10V output.

### 12.5.6.4 Economizer Control

The economizer will be enabled when there is a call for cooling and the outdoor is more favorable than the return air. In this case it will open the bypass damper to bypass the enthalpic core and thus inhibit the exchange of energy. During this time the unit still uses 100% OA.

Economizing is allowed when both of the following are below their limit:

- Analog Value 52 “Economizer.Econ\_Low\_OA\_Temp\_Limit”
- Analog Value 58 “Economizer.Econ\_Low\_RA\_Temp\_Limit”

### 12.5.7 Frost Control

The frost control function is enabled, when the OA is lower than Analog Value 77 “Defrost\_OA\_SetP.Val” minus Analog Value 78 “Defrost\_OA\_SetP.DBright,” and turns off again when the OA exceeds the AV77. During this time, the supply fan is OFF and the OA damper is closed.

### 12.5.8 Filter Monitoring

Filter pressures are read through Analog Input 24 “RA\_Flt\_Press.Val” and Analog Input 25 “OA\_Flt\_Press.Val.”

Filter alarm levels are set at Analog Value 35 “RA\_Flt\_AlarmHigh” and Analog Value 36 “OA\_Flt\_AlarmHigh.”

### 12.5.9 Exhaust Fan Only Mode

If BMS control is enabled, the unit can also be put in exhaust fan only mode in occupied operation using Binary Value 74 “UnitOnOffMng.BMSEFOnly.”

## 12.6 ADDING A BACNET LICENSE

### 12.6.1 Obtaining a BACnet License

If your controller does not have a BACnet license, contact whoever provided the unit to obtain one. You will need the Hardware ID number on this screen when ordering. Be sure to copy it carefully or the license will not work.

```

GENERAL SETTINGS
BACnet License
Installed? NO

Hardware ID:
0000000000000000
THIS EXACT NUMBER IS
REQ TO ORDER LICENSE
  
```

The license will be delivered as a file with extension “.ap1.”

### 12.6.2 Installing the BACnet License via Web Page

#### Prerequisites

- Have ap1 BACnet upgrade file(s) located on your PC
- Ethernet connection from the PC to the controller and view the web page

#### Steps

1. Go to the Upgrade Tab in the web pages.



2. Click on "CHOOSE FILE" and locate the file on your PC that corresponds to the controller.  
HINT: The ending character in the UID of the controller should match the character of the ap1 file. Click "OPEN."
  3. You should now see that file name next to "CHOOSE FILE." Click "Upload AP1 to c.pco." You will see the file upload.
  4. On the controller the program will see the file and require you to push "ENTER." You can see that on the front of the controller itself or on the RUT page of the web pages.
  5. Once the upgrade is finished the controller will ask you to reboot.
- You can then verify that the license is installed by going to the RUT page.

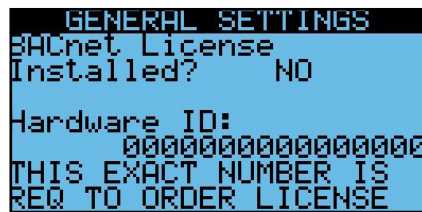

### 12.6.3 Installing the BACnet License via USB Drive

#### Prerequisites

- Micro USB Adapter.
- USB Stick with the file in a folder in the root called "UPGRADE." The file you received should be in that folder.

#### Steps

1. Carefully insert the micro USB end into the controller front under the door with the wide side to the bottom.
2. You should now see a prompt telling you press the enter key.
3. Once finished you will be prompted to press "ENTER" again.

You should now see the license is installed in the controller screen.

### 12.6.4 Installing the BACnet License via USB Connection

#### Prerequisites:

- PC
- Micro USB cable with the ability to plug in with a PC and have the controller appear as a USB drive in your Windows Explorer

#### Steps

1. Carefully insert the micro USB end into the controller front under the door with the wide side to the bottom.
2. You should see a folder called "UPGRADE" in the controller. Put the file in that folder. 3. Once finished you will be prompted to press "ENTER" again.

You should now see the license is installed in the controller screen.

## 12.7 MODBUS

The Modbus utilizes the standard registers and references them as an offset. For example, an offset of Input Register 0 is Register 30,001 and an offset for Holding Register 0 is register 40,001. All values are shown in decimal format. The implementation also uses Coils and Discrete Inputs in a similar manner.

### 12.7.1 Modbus TCP Connection

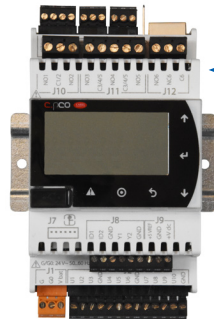

Connection of Modbus TCP requires a physical cable connection to the RJ45 jack on the controller. Prior to making the wiring connections, the controller is to be tested to verify proper control of the ERV unit under local control.

FIGURE 12.2.0 ETHERNET CONNECTION

**NOTE:** The controller will only support private IP addresses which start with 192, 172, or 10.

### 12.7.2 Modbus TCP Settings

First, set the IP address of the controller in the same *General Settings* area.

- Set DHCP to Off if static
- If Static, set the IP, mask, and gateway if required.
- *Set Update?* To Yes (Power will need to be cycled. This can be done after all of the other settings.)

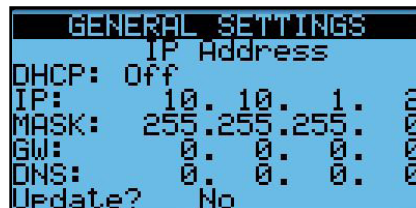

Then set the timeout parameter, if needed.

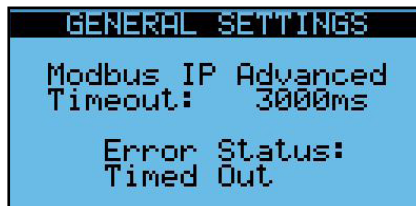

### 12.7.3 Modbus RTU Settings

First, set the address, baud rate, stop bits and parity.

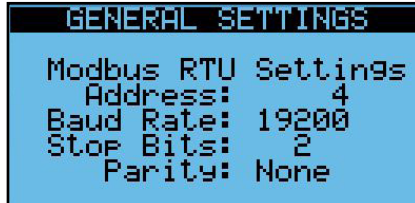

Then set the timeout parameter if needed.

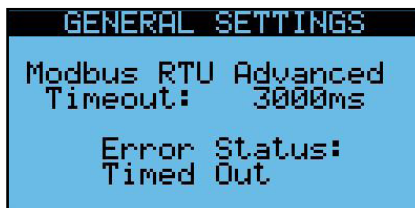

### 12.7.4 Modbus RTU Wiring

The Modbus RTU network is wired into the four-pin connector named J3 Disp. In the upper left-hand corner of the controller. This is also used for a RUT display so the two cannot be used at the same time. For Modbus RTU, use the plus (+) and minus (-), as well as the GND for reference if desired.

DO NOT use the +Vterm terminal. If you happen to plus a three-pin block in here and use the wrong three pins you might damage the port.

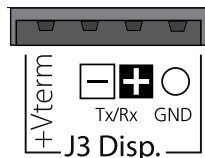

## 12.8 MODBUS REGISTER LIST

Modbus Registers with an offset of 0 have been duplicated at register 98 to accommodate Automated Logic Systems and other systems that cannot map 0.

TYPE	#	VARIABLE	DESCRIPTION	RANGE	READ/WRITE MODE (RET)
Coil	0	OnOffUnitMng.BmsOnOff	BMS On/Off Command	Off/On	Read_Writeable
Coil	1	OnOffUnitMng.BmsEfOnly	BMS Exhaust Fan Only Command	Off/On	Read_Writeable
Coil	2	AlarmMng.AlrmResByBms	Alarm Reset BMS Command	OK/Reset	Read_Writeable
Coil	4	BMS_SetHeatCool	BMS Set Heat/Cool Capability	No/Allow	Read_Writeable (X)
Coil	5	BMS_HeatCoolMode	BMS Heat/Cool Mode Setting	Heat/Cool	Read_Writeable (X)
Coil	3	OnOffUnitMng.BmsUnocc	BMS Unoccupied Command	Occ/Unocc	Read_Writeable
Coil	6	BMS_HW_Valve_Control	BMS HW Valve Control	No/Allow	Read_Writeable
Coil	7	Heating_Enable_1.Val	Heating Stage 1 BMS Enable	Off/On	Read_Writeable
Coil	98	OnOffUnitMng.BmsOnOff	BMS On/Off Command	Off/On	Read_NoWrite
DiscreteInput	0	OA_Damp.Val	OA Damper Command	Closed/Open	Read_NoWrite
DiscreteInput	1	RA_Damp.Val	RA Damper Command	Closed/Open	Read_NoWrite
DiscreteInput	16	Tempering_Mode.Val	Tempering Mode	Heat/Cool	Read_NoWrite
DiscreteInput	2	AlarmMng.AlrmRes	Alarm Reset Status	No/Yes	Read_NoWrite
DiscreteInput	3	SF_Status.Val	SF Status from Current Sensor	Off/On	Read_NoWrite
DiscreteInput	4	EF_Status.Val	EF Status from Current Sensor	Off/On	Read_NoWrite
DiscreteInput	5	Alarm_Out.Val	Serious Alarm (Also a physical output)	OK/Alarm	Read_NoWrite
DiscreteInput	6	Heating_Enable_1.Val	Heating Stage 1	Off/On	Read_NoWrite
DiscreteInput	7	Cooling_Stage_1.Val	Cooling Stage 1	Off/On	Read_NoWrite
DiscreteInput	8	Cooling_Stage_2.Val	Cooling Stage 2	Off/On	Read_NoWrite
DiscreteInput	9	UnitOn	Unit On Status	Off/On	Read_NoWrite
DiscreteInput	10	OfflineAlrm_CPCOE_1.Active	Device offline alarm CPCOE	OK/Alarm	Read_NoWrite
DiscreteInput	21	Al_SupplyFan.Active	Supply Fan Start Alarm	OK/Alarm	Read_NoWrite
DiscreteInput	22	Al_ExhaustFan.Active	Exhaust Fan Start Alarm	OK/Alarm	Read_NoWrite
DiscreteInput	12	Bypass_Damp.Val	Bypass Damper Command	Close/Open	Read_NoWrite
DiscreteInput	13	Heating_Enable_2.Val	Heating Stage 2	Off/On	Read_NoWrite
DiscreteInput	20	Any_Alarm_Out.Val	Any Alarm is True Status	OK/Alarm	Read_NoWrite
DiscreteInput	98	OA_Damp.Val	OA Damper Command	Closed/Open	Read_NoWrite
HoldingRegister	44	HeatingCommand_BMS	Heating Command from BMS	%	Read_Writeable
HoldingRegister	0	RA_Flt_AlarmHigh	RA Filter Alarm Level	iwc	Read_Writeable (X)

TYPE	#	VARIABLE	DESCRIPTION	RANGE	READ/WRITE MODE (RET)
HoldingRegister	2	OA_Fit_AlarmHigh	OA Filter Alarm Level	iwc	Read_Writeable (X)
HoldingRegister	4	SF_ConstSpeedSetP.Val	SF Const Speed Setpoint	%	Read_Writeable (X)
HoldingRegister	6	SF_FlowControlSetP.Val	SF Flow Control Setpoint	CFM	Read_Writeable (X)
HoldingRegister	8	SF_DuctStaticSetP.Val	SF Duct Static Pressure Setpoint	iwc	Read_Writeable (X)
HoldingRegister	12	SF_CO2_SetP.Val	SF CO2 Setpoint	PPM	Read_Writeable (X)
HoldingRegister	14	SF_VOC_SetP.Val	SF VOC Setpoint	PPM	Read_Writeable (X)
HoldingRegister	16	EF_ConstSpeedSetP.Val	EF Constant Speed Setpoint	%	Read_Writeable (X)
HoldingRegister	18	EF_FlowControlSetP.Val	EF Flow Control Setpoint	CFM	Read_Writeable (X)
HoldingRegister	20	EF_SF_TrackingSetP.Val	EF SF Tracking Setpoint	%	Read_Writeable (X)
HoldingRegister	22	EF_RoomStaticSetP.Val	EF Room Static Setpoint	iwc	Read_Writeable (X)
HoldingRegister	24	CoolLockoutTemp	OA Cooling Lockout Temperature	F	Read_Writeable (X)
HoldingRegister	26	HeatLockoutTemp	OA Heating Lockout Temperature	F	Read_Writeable (X)
HoldingRegister	34	BMS_CO2_Reading	BMS CO2 Reading (in lieu of attached sensor)	PPM	Read_Writeable
HoldingRegister	36	BMS_SpacePressPress_Reading	BMS Space Pressure	iwc	Read_Writeable (X)
HoldingRegister	38	Occ_HTG_Setp.Val	Occupied Heating Setpoint	F	Read_Writeable (X)
HoldingRegister	40	Occ_CLG_Setp.Val	Occupied Cooling Setpoint	F	Read_Writeable (X)
HoldingRegister	52	SF_CO2_VOCFlowMinCO2.Val	SF Flow: MinCO2	PPM	Read_Writeable (X)
HoldingRegister	54	SF_CO2_FlowMaxCO2.Val	SF Flow: Max CO2	PPM	Read_Writeable (X)
HoldingRegister	56	SF_CO2_FlowMinFlow.Val	SF Flow: Min Flow	CFM	Read_Writeable (X)
HoldingRegister	58	SF_CO2_FlowMaxFlow.Val	SF Flow: Max Flow	CFM	Read_Writeable (X)
HoldingRegister	98	RA_Fit_AlarmHigh	RA Filter Alarm Level	iwc	Read_Writeable (X)
InputRegister	0	OA_Temp.Val	OA Temperature	F	Read_NoWrite
InputRegister	2	OA_Hum.Val	OA Relative Humidity	%	Read_NoWrite
InputRegister	4	RA_Temp.Val	RA Temperature	F	Read_NoWrite
InputRegister	6	RA_Hum.Val	RA Relative Humidity	%	Read_NoWrite
InputRegister	8	EA_Temp.Val	EA Temperature	F	Read_NoWrite
InputRegister	10	SA_Temp.Val	SA Temperature (before tempering)	F	Read_NoWrite
InputRegister	12	OA_Flow_Rate.Val	OA Flow Rate	CFM	Read_NoWrite
InputRegister	14	EA_Flow_Rate.Val	EA Flow Rate	CFM	Read_NoWrite
InputRegister	16	RA_Fit_Press.Val	RA Filter Pressure	iwc	Read_NoWrite
InputRegister	18	OA_Fit_Press.Val	OA Filter Pressure	iwc	Read_NoWrite

TYPE	#	VARIABLE	DESCRIPTION	RANGE	READ/WRITE MODE (RET)
InputRegister	20	SF_Command.Val	Supply Fan Command (actual)	%	Read_NoWrite
InputRegister	22	EF_Command.Val	Exhaust Fan Command (actual)	%	Read_NoWrite
InputRegister	24	CO2_Level.Val	CO2 Level	PPM	Read_NoWrite
InputRegister	26	VOC_Level.Val	VOC Level	PPM	Read_NoWrite
InputRegister	28	Space_Press.Val	Space Pressure	iwc	Read_NoWrite
InputRegister	30	Duct_Press.Val	Duct Pressure	iwc	Read_NoWrite
InputRegister	32	CA_Temp.Val	CA Temperature (after tempering)	F	Read_NoWrite
InputRegister	34	Cooling_Command.Val	Cooling Command	%	Read_NoWrite
InputRegister	36	Heating_Command.Val	Heating Command from Program	%	Read_NoWrite
InputRegister	98	OA_Temp.Val	OA Temperature	F	Read_NoWrite
InputRegister	42	SF_ControlType_BN	SF_ControlType_BN	(See Notes)	Read_NoWrite
InputRegister	43	EF_ControlType_BN	EF_ControlType_BN	(See Notes)	Read_NoWrite
InputRegister	44	HTG_ControlType_BN	HTG_ControlType_BN	(See Notes)	Read_NoWrite
InputRegister	45	CLG_ControlType_BN	CLG_ControlType_BN	(See Notes)	Read_NoWrite
InputRegister	48	Heating_SetPtType_BN	Heating_SetPtType_BN	(See Notes)	Read_NoWrite
InputRegister	50	UnitStatus_BN	UnitStatus_BN	(See Notes)	Read_NoWrite

## 12.9 MODBUS APPLICATION NOTES

### 12.9.1 Turning the Unit ON and OFF

If you plan to use the BMS to turn the unit on and off, make sure you have the control enabled through the keypad. Use Modbus Coil “OnOffUnitMng.BmsOnOff” at Coil 0. The status can be read at “UnitOn” at Discrete Input 9.

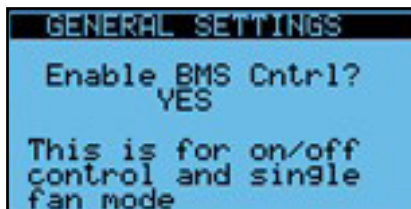

All of the following have to be true in order for the unit to be on:

- There are no serious alarms.
- The Digital Input for start/stop (orange DIN terminal to black DIN terminal) are closed.
- The unit is turned on at the keypad.
- The time is within the scheduler “ON” time, if scheduler enabled.
- The BMS has written the unit on signal, if BMS control is enabled.

UNITSTATUS_BN: INPUT REGISTER 50		
VALUE	STATUS	MEANING
1	Unit on	The unit is on and running.
2	Unit switched off due to alarm	The unit is off by a serious alarm.
3	Unit switched off by BMS	The unit is off by command from the BMS.
4	Unit switched off by time band	The unit is off by the scheduler.
5	Unit switched off by digital input	The unit is off due to the ID1 input not being connected to COM.
6	Unit switched off from the local keypad	The unit is off by the setting on the menu screen.
8	Exhaust Fan Only Mode	The unit is in single fan mode with exhaust fan running.
9	Supply Fan Only Mode	The unit is in single fan mode with supply fan running.
11	Cool Locked Out by BMS	A BMS command has the cooling locked out.
12	Heat Locked Out by BMS	A BMS command has the heating locked out.
13	Device Test	The system is in device test mode for more than an hour.
14	Sens Ovrd Active	The system has a sensor overwritten for more than 24 hours.
15	Off by CO2 Level	Off by CO2 Level.
16	Frost Control On	Frost Control Mode Active.

### 12.9.2 Alarms

Two general alarms are available:

- Serious Alarm: Located at Discrete Input 5, “Alarm\_Out.val” indicates whether there is a serious alarm that stops the unit.
- Any Alarm: Located at Discrete Input 20, “Any\_Alarm\_Out.val” indicates whether there is any alarm present.

To reset the User Reset type alarms, set Coil 0 (or 98) “AlarmMng.AlrmResByBMS” to true. The program will set it back to false. You can view the status change through Discrete Input 2 “AlarmMng.AlrmRes.”

### 12.9.3 Temperature and Humidity Around the ERV

The following are available:

- Input Register 0 “OA\_Temp.Val”
- Input Register 2 “OA\_Hum.Val”
- Input Register 4 “RA\_Temp.Val”
- Input Register 6 “RA\_Hum.Val”
- Input Register 8 “EA\_Temp.Val”
- Input Register 10 “SA\_Temp.Val”

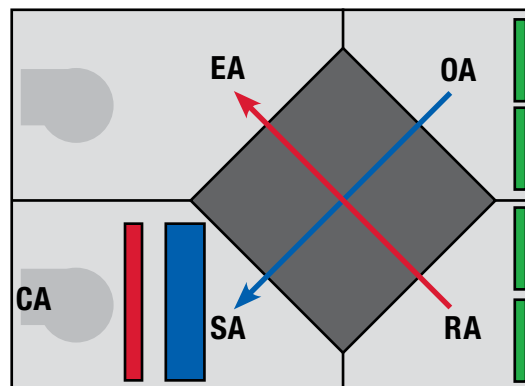

#### 12.9.4 Fan Control

The supply fan control type method can be viewed at Input Register 42 “SF\_ControlType\_BN.” The valid values are 0 = Constant Speed, 1 = Supply Airflow, 2 = Duct Static Pressure, 3 = CO2/VOC, 4 = CO2/VOC Flow.

The corresponding settings are as follows:

- Constant Speed setpoint is Holding Register 4 “SF\_ConstantSpeedSetP.Val”
- Supply Airflow setpoint is Holding Register 6 “SF\_FlowControlSetP.Val”
- Duct Static setpoint is Holding Register 8 “SF\_DuctStaticSetP.Val”
- CO2/VOC setpoint is Holding Register 12 “SF\_CO2\_VOCSetP.Val”
- CO2/VOC Flow ramp set at Holding Registers 52, 54, 56, and 58.

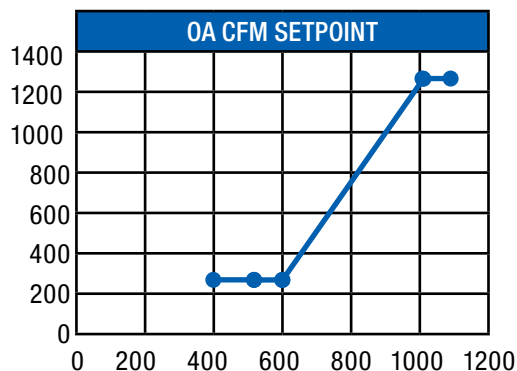

The command to the fan is read at Input Register 20 “SF\_Command.Val.” The feedback from the current sensor is read at Discrete Input 3 “SF\_Status.Val.” The actual flow rate is viewed at Input Register 12 “OA\_Flow\_Rate.Val.”

The exhaust fan control type method can be viewed at Input Register 43 “EF\_ControlType\_BN.” The valid values are 1 = Constant Speed, 2 = Exhaust Airflow, 3 = SF Command Tracking, 4 = SF Flow Tracking, 5 = Return Static Pressure.

The corresponding settings are as follows:

- Constant Speed setpoint is Holding Register 16 “EF\_ConstantSpeedSetP.Val”
- Exhaust Airflow setpoint is Holding Register 18 “EF\_FlowControlSetP.Val”
- Exhaust Fan Tracking setpoint is Holding Register 20 “EF\_SF\_TrackingSetP.Val”
- Return Static setpoint Holding Register 22 “EF\_ReturnStaticSetP.Val”

The command to the fan is read at Input Register 22 “EF\_Command.Val.” The feedback from the current sensor is read at Discrete Input 4 “EF\_Status.Val.” The actual flow rate is viewed at Input Register 14 “EA\_Flow\_Rate.Val.”

#### 12.9.5 BMS Direct Fan Control

Available in ERV versions 03\_00\_26 ERV and higher.

Normally we use the setpoints below for constant speed fan control. These are retained variables that are kept on power loss and should not be written to constantly. You will get an alarm error and/or damage the controller by doing so.

Normal setpoint registers for constant speed fan control:

- SF\_ConstSpeedSetP.Val HR4
- EF\_ConstSpeedSetP.Val HR16

The newer versions allow a BMS system to command directly to the speed control with a non-retained variable. This is done with systems where the BMS is writing to the value every program cycle. One example would be when they use their own pressure control loop and only write the output to the fan.

The fan settings for supply and exhaust fan are independent. The user must set the control for that fan to constant speed control.

The registers used for reading the fan control type are:

- SF\_ControlType\_BN IR42
- EF\_ControlType\_BN IR43

They must be set on these screens.

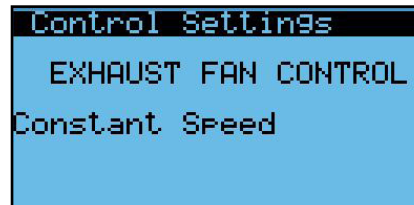

In order to use this feature, the settings must be set in this screen, located in the General Settings near the other BMS settings. The user must set the corresponding fan to “YES.”



The registers used for direct writing the percentages are:

- BMS\_SupplyFanCommand HR70 expressed as 0-100%
- BMS\_ExhaustFanCommand HR72 expressed as 0-100%

In the screen above you will be able to see the value of these objects under “Current Value” for troubleshooting purposes.

The Control Setting Screen will no longer be available. Instead, the following screen(s) will be shown accordingly, with the current command shown being read-only on the screen.

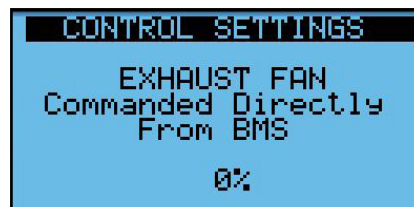

#### 12.9.6. Tempering Control

The ERV unit may provide heating and cooling/if ordered as such. For heating and/or cooling, there will be a conditioned air temperature sensor which measured the air coming out of the unit as Input Register 32 “CA\_Temp.Val.”

### 12.9.6.1 Determining Tempering Mode

To determine the mode in which the unit is operating, the following values are considered:

- Holding Register 26 “HeatLockoutTemp”
- Holding Register 24 “CoolLockoutTemp”

In addition, the BMS has the potential to use one more setting to determine whether the unit will lock out heating or cooling functions. This is required for the dual temp systems and may be useful for other situations. The Coil 4 “BMS\_SetHeatCool” must be true and then the mode is set through Coil 5 “BMS\_HeatCoolMode” where 0 =Heat and 1 = Cool. The BMS mode is shown for troubleshooting.

```

GENERAL SETTINGS
BMS Heat Cool Mode:
NO
NOTE: If set to yes,
other mode will be
locked out.
Current Mode: Heat
  
```

The current Tempering Mode is viewed at Discrete Input 16 “Tempering\_Mode.Val.” It is also an output used for VRF applications. The tempering mode will show heating when in heating or ventilation only mode, and cooling for cooling mode.

### 12.9.6.2 Heating Control

The heating control type is located at Input Register 44 “HTG\_ControlType\_BN.” The setpoint is Holding Register 38 “Occ\_HTG\_SetP.Val” if adjustable setpoint is chosen. Otherwise the setpoint is based on an outdoor temperature schedule. The type is Input Register 48 “Heating\_SetPtType\_BN,” where 1 = Adjust and 2 = OA Reset. The acting setpoint is Input Register 46 “HTG\_SetP\_Adjusted.”

The heating output statuses are the following:

- Discrete Input 6 “Heating\_Enable\_1.Val” for stage one or modulating types where the demand is greater than 0
- Discrete Input 13 “Heating\_Enable\_2.Val” for stage two
- Input Register 36 “Heating\_Command.Val” shows a percentage for the 0–10V output.

It is also possible for the BMS to take over total control of the 10–0V hot water valve signal out to the controlled valve and heating output directly for special cases. All setpoints, etc. will be ignored in this case. To do this, set the heating setting “Valve Control” to BMS on the screen, or through Binary Value 74 “BMS\_HW\_Valve\_Control.”

```

CONTROL SETTINGS
HEATING
10-0 UDC - Adjustable
Setpoint 75.2f
KP 1.0
Ti 30
Valve Control BMS
  
```

Then control the valve through

- Holding Register 44 “HeatingCommand\_BMS” to set a value for the 0–10V output, where 0 is 0V and 100 is 10V.
- Coil 7 “Heating\_Enable\_1.Val” can also be controlled directly if needed.

### 12.9.6.3 Cooling Control

The cooling control type is located at Input Register 45 “CLG\_ControlType\_BN.” The setpoint is Holding Register 40 “Occ\_CLG\_SetP.Val.”

The cooling output statuses are the following:

- Discrete Input 7 “Cooling\_Enable\_1.Val” for stage one or modulating types where the demand is greater than 0
- Discrete Input 8 “Cooling\_Enable\_2.Val” for stage two
- Input Register 34 “Cooling\_Command.Val” shows a percentage for the 0–10V output.

### 12.9.6.4 Economizer Control

The economizer will be enabled when there is a call for cooling and the outdoor is more favorable than the return air. In this case it will open the bypass damper to bypass the enthalpic core and thus inhibit the exchange of energy. During this time the unit still uses 100% OA.

Economizing is allowed when both of the following Are below their limit:

- Holding Register 30 “Economizer.Econ\_Low\_OA\_Temp\_Limit”
- Holding Register 42 “Economizer.Econ\_Low\_RA\_Temp\_Limit”

### 12.9.7 Frost Control

The frost control function is enabled, when the OA is lower than Holding Register 64 “Defrost\_OA\_SetP.Val” minus Holding Register 66 “Defrost\_OA\_SetP.DBright,” and turns off again when the OA exceeds the HR66. During this time, the supply fan is OFF and the OA damper is closed.

### 12.9.8 Filter Monitoring

Filter pressures are read through Input Register 16 “RA\_Flt\_Press.Val” and Input Register 18 “OA\_Flt\_Press.Val.”

Filter alarm levels are set at Holding Register 0 (or 98) “RA\_Flt\_AlarmHigh” and Holding Register 2 “OA\_Flt\_AlarmHigh.”

### 12.9.9 Exhaust Fan Only Mode

If BMS control is enabled, the unit can also be put in exhaust fan only mode in occupied operation using Coil 1 “UnitOnOffMng.BMSEFOnly.”

## 13.0 ADVANCED SERVICE

This area gives advanced service information, as described. These screens are used infrequently.

### 13.1 RUN HOURS AND STARTS

For the ERV unit as well as each fan and compressor, if applicable, there is a screen that shows the run hours as well as the number of starts. This screen also lets you specify a threshold for alarm to alert that service is required and the ability to reset those numbers once service is performed.



### 13.2 LAST POWER LOSS

This screen gives information on the last time the unit was powered down as well as the length of time the unit was powered down for troubleshooting.

```

ADVANCED SERVICE
LAST POWER LOSS
Current time:
18/12/25 13:56:06
PowerOff time:
11/12/25 14:30:48
Length last time off:
 0Days  0Hrs 11Min
    
```

### 13.3 INTERNAL MEMORY WRITES

This screen gives information memory writes and the cycle speed of the applications. This would normally be used to give information to TSS, if requested.

```

ADVANCED SERVICE
Ret mem writes: 2526
Main task:
500ms 2.0Cycle/s
    
```

### 13.4 ALARM INITIALIZATION

This screen will allow you to delete the alarm logs.

```

ADVANCED SERVICE
Alarm initialization
Delete alarm logs? NO
    
```

### 13.5 MEMORY WIPE

This screen will allow to wipe retained values (most setpoints) and/or NVRAM (clock and IP settings). You should only use this screen if directed to do so by TSS.

```

ADVANCED SERVICE
DEFAULT INSTALLATION
Wipe retain mem.: NO
Wipe NVRAM mem.: NO
Wipe both mem.: NO
    
```

### 13.6 COMMUNICATION TO EXPANSION MODULE

This screen allows you to see the status of the communication to the expansion module. TSS may request this information for troubleshooting.

```

$ ADVANCED SERVICE
COMM TO EXP MOD
Dev Err: OK
Err Code: 0
Err ID: 0times
Poll ID: 441907times
    
```





**14.3 CONTROLLER UPDATES**

Anytime an updated controller program is provided by the factory and installed by the user, it should be recorded here:

DATE

**14.4 SETTINGS BACKUP FILE**

Use this space to record whether or not a backup has been performed to an external memory device (USB stick) and indicate where the USB stick is to be found.

Controller System Backup has been performed:  Yes

Type/ID of memory device:

Storage location of external memory device:

## 15.0 REFERENCE

### 15.1 TUNING PI CONTROL LOOPS

For any heating or cooling device that has a variable output and uses a variable control signal (including HGRH), the desired action is for the heating/cooling device to reach the setpoint quickly and smoothly. The controller monitors a selected temperature sensor and any variation from the setpoint is considered “ERROR.” The controller senses the Error and sends a control signal (call for heat or call for cooling) to the heating/cooling device. This control signal is referred to as a “command.” For most variable output hardware, the command will be an analog 0–10VDC signal.

This controller uses PI programming to control the response to Error. PI programming uses two different types of settings to control the command; KP and Ti

KP = proportional gain

- Responds directly to difference between setpoint and actual
- Larger KP values will cause a greater output response and eventually will oscillate.

Ti = integral band

- Responds to the accumulated difference between setpoint and actual
- Larger Ti values will cause a slower output response, very small values eventually will oscillate.

CONTROL SETTINGS	
COOLING - PDX	
Setpoint	45.0°F
KP	7.0
Ti	100

#### 15.1.1 Proportional Constant (KP)

The Proportional Constant (KP) determines the strength of the command for any given error.

**Example:** the setpoint in a heating system is 72°F. The actual temperature is 71°F so the Error is 10°F, which requires very little heat from the heater. The controller sees there is an error and immediately sends a call for heat that starts at 0.1% strength and ramps up as needed, but the rate of increase tapers off as the Error decreases. The rate of increase is proportional to the amount of Error. When the controller senses that the Error is decreasing, it will slow the rate of increase of the command.

- When the Error is small, the rate of increase of the command is slow.
- When the Error is large, the rate of increase is greater (the command responds proportionally to the amount of Error).

The factory default KP setting for most heating and cooling devices is 1, which produces a low and slow response. If the response is too slow, the KP setting can be increased so that the command will be stronger and faster.

**Example:** when the KP setting is 1 and Ti is set for 30 (the factory defaults) and there is a 1°F Error, it takes about 50 seconds for the command to change by 10%. If the KP setpoint is changed to 10, it takes about 5 seconds for the command to change by 10%. For most installations, the KP value will have to be increased to speed up changes in the command signal to an acceptable level. Setting the KP value too high will result in the heater/cooler overshooting the setpoint constantly.

- If the KP value is too low, the command will change too slowly and the setpoint may take too long to reach.
- If the KP value is too high, the command will change to 100% too quickly and the setpoint will be over-shot. This results in the heating/cooling device switching “ON” and “OFF” constantly.

### 15.1.2 Time Integral (Ti)

If the KP setting did not have some means of control, the resulting command signals would constantly over-shoot the setpoint. The Time Integral causes the controller to re-examine the amount of error at specific time intervals to see the amount of error remaining. Ti produces a damping effect on the KP value to reduce over-shooting the setpoint. Ti is an actual measure of time so that when the value is reduced, the frequency of sampling increases.

**Example:** the default Ti value is 30. If the value were changed to 15, sampling would occur twice as often. If the value were changed from 30 to 60, sampling would occur only half as often. If Ti were changed to 500, the result is that the sampling value would be insignificant and corrections to KP would not be happening.

- If the Ti value is set too low (meaning that sampling is occurring too often), the increase in the command signal will immediately begin to slow and keep getting slower because Ti is damping the KP value too much.
- If Ti is set too high (sampling is not occurring often enough), the Command signal will overshoot the setpoint in both a negative and positive direction, causing short-cycling of the heating device.

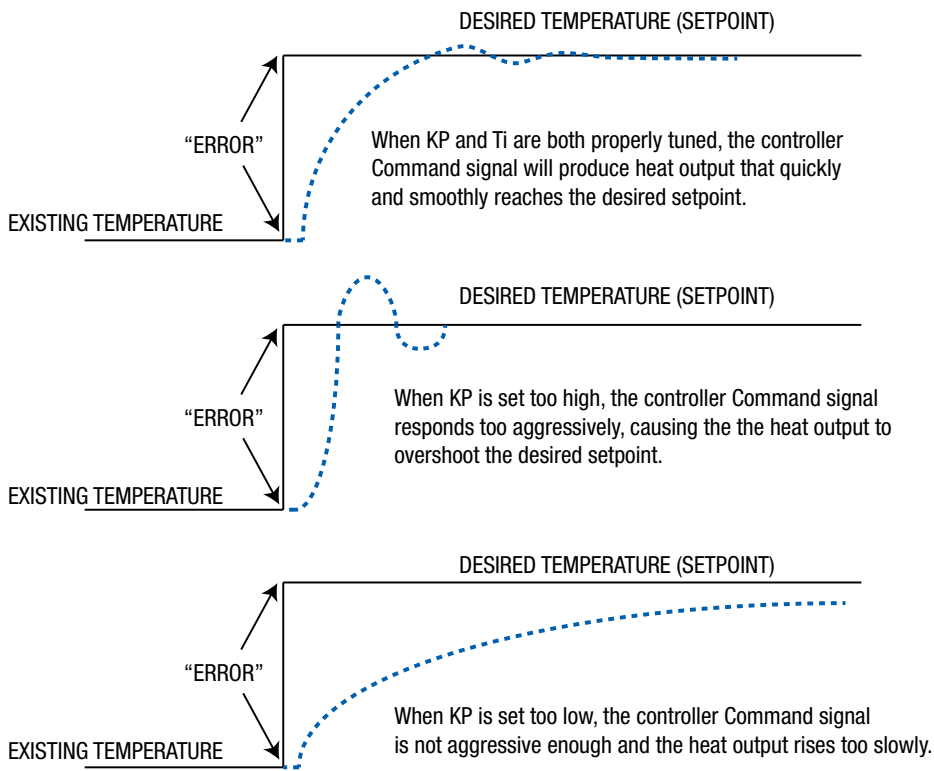

FIGURE 15.1.0 KP SETPOINT CHARTS

The process of adjusting KP and Ti to provide the most satisfactory controller output is known as tuning the controller. There are some sophisticated math equations that can be done to predict where the KP and Ti settings should be, but in the field, adjustment is normally done by a trial-and-error method. The KP setting is first adjusted and then the Ti setting is adjusted to manage the KP setting.

Tools needed:

- Laptop computer to view the Heating screens and make adjustments to KP and Ti.
- A stopwatch or watch with a second hand to monitor times.
- Connect the laptop to the controller via ethernet.

### 15.1.3 Establish a KP Setting

Use the KP Adjustment Chart to track and log test trials of different controller settings. Make copies of the adjustment charts, as needed.

- Go to Main Menu > Unit Status > Heating. Note the temperature here.
- Go to Main Menu > Control Settings> Heating.
- Set the KP value at 5.
- Set the Ti value at 500. This will make the sampling frequency so low that it is essentially of no consequence and permits adjustment of KP without being affected by Ti.
- Set the setpoint for 20°F warmer than the current temperature as noted above. (Change the setpoint last because the controller will immediately respond to the setpoint change, using the KP and Ti settings that it currently has.)
- Click the “ENTER” button and then immediately go back to Main Menu > Unit Status > Heating.

View the Command and Temperature lines on the screen and enter the data at each time interval that was selected.

When the trial is complete, view the Command line on the chart to see how quickly it ramps up to 100%. If the Command percentage is rising too slowly, increase the KP value and run the trial again. The Command percentage should reach 100% (or very nearly) within 2–4 minutes.

Repeat the process, but move the heating setpoint 20°F lower than the current temperature and change the KP value to a larger value, possibly 10 or 15 larger than the previous trial.

Make data entries on the KP Adjustment Chart (following page) to help track changes to the KP settings. Select the most appropriate KP setting.

### 15.1.4 Establish a Ti Setting

- Leave the KP value as found above.
- Set the Ti value at the default value of 30. For each trial, increase the Ti setting.
- Follow the same process as described above. Repeat the trials until the smoothest response is found that does not cause over-shooting or oscillation of the heating command.

### 15.1.5 Verify the Combined KP and Ti Settings

When both KP and Ti have been set, run one final trial with the KP and Ti settings at their new values and record the results in the final chart. This ensures that the results are repeatable. Temperature and Command readings are obtained from Main Menu > Unit Status > Heating

For Elapsed Time, select a convenient amount of time to allow between readings (example: 30 seconds).

In the first column of each trial, fill in the starting data for the trial.

DEVICES BEING ADJUSTED

--

KP Adjustment Trial 1

KP SETTING	<input type="text"/>						
HEATING SETPOINT	<input type="text"/>						
TEMPERATURE	<input type="text"/>	<input type="text"/>	<input type="text"/>	<input type="text"/>	<input type="text"/>	<input type="text"/>	<input type="text"/>
COMMAND PERCENTAGE	<input type="text"/>	<input type="text"/>	<input type="text"/>	<input type="text"/>	<input type="text"/>	<input type="text"/>	<input type="text"/>
ELAPSED TIME	0	<input type="text"/>	<input type="text"/>	<input type="text"/>	<input type="text"/>	<input type="text"/>	<input type="text"/>

KP Adjustment Trial 2

KP SETTING	<input type="text"/>						
HEATING SETPOINT	<input type="text"/>						
TEMPERATURE	<input type="text"/>	<input type="text"/>	<input type="text"/>	<input type="text"/>	<input type="text"/>	<input type="text"/>	<input type="text"/>
COMMAND PERCENTAGE	<input type="text"/>	<input type="text"/>	<input type="text"/>	<input type="text"/>	<input type="text"/>	<input type="text"/>	<input type="text"/>
ELAPSED TIME	0	<input type="text"/>	<input type="text"/>	<input type="text"/>	<input type="text"/>	<input type="text"/>	<input type="text"/>

KP Adjustment Trial 3

KP SETTING	<input type="text"/>						
HEATING SETPOINT	<input type="text"/>						
TEMPERATURE	<input type="text"/>	<input type="text"/>	<input type="text"/>	<input type="text"/>	<input type="text"/>	<input type="text"/>	<input type="text"/>
COMMAND PERCENTAGE	<input type="text"/>	<input type="text"/>	<input type="text"/>	<input type="text"/>	<input type="text"/>	<input type="text"/>	<input type="text"/>
ELAPSED TIME	0	<input type="text"/>	<input type="text"/>	<input type="text"/>	<input type="text"/>	<input type="text"/>	<input type="text"/>

KP Adjustment Trial 4

KP SETTING	<input type="text"/>						
HEATING SETPOINT	<input type="text"/>						
TEMPERATURE	<input type="text"/>	<input type="text"/>	<input type="text"/>	<input type="text"/>	<input type="text"/>	<input type="text"/>	<input type="text"/>
COMMAND PERCENTAGE	<input type="text"/>	<input type="text"/>	<input type="text"/>	<input type="text"/>	<input type="text"/>	<input type="text"/>	<input type="text"/>
ELAPSED TIME	0	<input type="text"/>	<input type="text"/>	<input type="text"/>	<input type="text"/>	<input type="text"/>	<input type="text"/>

FIGURE 15.1.1 KP ADJUSTMENT WORKSHEET

DEVICES BEING ADJUSTED

--

Ti Adjustment Trial 1

Ti SETTING	<input type="text"/>	KP Setting for all Trials							<input type="text"/>
HEATING SETPOINT	<input type="text"/>								
TEMPERATURE	<input type="text"/>	<input type="text"/>	<input type="text"/>	<input type="text"/>	<input type="text"/>	<input type="text"/>	<input type="text"/>	<input type="text"/>	
COMMAND PERCENTAGE	<input type="text"/>	<input type="text"/>	<input type="text"/>	<input type="text"/>	<input type="text"/>	<input type="text"/>	<input type="text"/>	<input type="text"/>	
ELAPSED TIME	0	<input type="text"/>	<input type="text"/>	<input type="text"/>	<input type="text"/>	<input type="text"/>	<input type="text"/>	<input type="text"/>	

Ti Adjustment Trial 2

Ti SETTING	<input type="text"/>							
HEATING SETPOINT	<input type="text"/>							
TEMPERATURE	<input type="text"/>	<input type="text"/>	<input type="text"/>	<input type="text"/>	<input type="text"/>	<input type="text"/>	<input type="text"/>	<input type="text"/>
COMMAND PERCENTAGE	<input type="text"/>	<input type="text"/>	<input type="text"/>	<input type="text"/>	<input type="text"/>	<input type="text"/>	<input type="text"/>	<input type="text"/>
ELAPSED TIME	0	<input type="text"/>	<input type="text"/>	<input type="text"/>	<input type="text"/>	<input type="text"/>	<input type="text"/>	<input type="text"/>

Ti Adjustment Trial 3

Ti SETTING	<input type="text"/>							
HEATING SETPOINT	<input type="text"/>							
TEMPERATURE	<input type="text"/>	<input type="text"/>	<input type="text"/>	<input type="text"/>	<input type="text"/>	<input type="text"/>	<input type="text"/>	<input type="text"/>
COMMAND PERCENTAGE	<input type="text"/>	<input type="text"/>	<input type="text"/>	<input type="text"/>	<input type="text"/>	<input type="text"/>	<input type="text"/>	<input type="text"/>
ELAPSED TIME	0	<input type="text"/>	<input type="text"/>	<input type="text"/>	<input type="text"/>	<input type="text"/>	<input type="text"/>	<input type="text"/>

Ti Adjustment Trial 4

Ti SETTING	<input type="text"/>							
HEATING SETPOINT	<input type="text"/>							
TEMPERATURE	<input type="text"/>	<input type="text"/>	<input type="text"/>	<input type="text"/>	<input type="text"/>	<input type="text"/>	<input type="text"/>	<input type="text"/>
COMMAND PERCENTAGE	<input type="text"/>	<input type="text"/>	<input type="text"/>	<input type="text"/>	<input type="text"/>	<input type="text"/>	<input type="text"/>	<input type="text"/>
ELAPSED TIME	0	<input type="text"/>	<input type="text"/>	<input type="text"/>	<input type="text"/>	<input type="text"/>	<input type="text"/>	<input type="text"/>

FIGURE 15.1.2 TI ADJUSTMENT WORKSHEET

**15.2 TEMPERATURE SENSOR CURVE**

Only sensors with this Carel curve should be used with this system.

°C	°F	KΩ
-50.0	-58.0	329.20
-49.0	-56.2	310.70
-48.0	-54.4	293.30
-47.0	-52.6	277.00
-46.0	-46.0	261.80
-45.0	-49.0	247.50
-44.0	-47.2	234.10
-43.0	-45.4	221.60
-42.0	-43.6	209.80
-41.0	-41.8	198.70
-40.0	-40.0	188.40
-39.0	-38.2	178.30
-38.0	-36.4	168.90
-37.0	-34.6	160.10
-36.0	-32.8	151.80
-35.0	-31.0	144.00
-34.0	-29.2	136.60
-33.0	-27.4	129.70
-32.0	-25.6	123.20
-31.0	-23.8	117.10
-30.0	-22.0	111.30
-29.0	-20.2	105.70
-28.0	-18.4	100.40
-27.0	-16.6	95.47
-26.0	-14.8	90.80
-25.0	-13.0	86.39
-24.0	-11.2	82.22
-23.0	-9.4	78.29
-22.0	-7.6	74.58
-21.0	-5.8	71.07
-20.0	-4.0	67.74
-19.0	-2.2	64.54
-18.0	-0.4	61.52
-17.0	1.4	58.66
-16.0	3.2	55.93
-15.0	5.0	53.39
-14.0	6.8	50.96
-13.0	8.6	48.65
-12.0	10.4	46.48
-11.0	12.2	44.41
-10.0	14.0	42.25

°C	°F	KΩ
-9.0	15.8	40.56
-8.0	17.6	38.76
-7.0	19.4	37.05
-6.0	21.2	35.43
-5.0	23.0	33.89
-4.0	24.8	32.43
-3.0	26.6	31.04
-2.0	28.4	29.72
-1.0	30.2	28.47
0.0	32.0	27.23
1.0	33.8	26.13
2.0	35.6	25.03
3.0	37.4	23.99
4.0	39.2	22.99
5.0	41.0	22.05
6.0	42.8	21.15
7.0	44.6	20.29
8.0	46.4	19.40
9.0	48.2	18.70
10.0	50.0	17.96
11.0	51.8	17.24
12.0	53.6	16.55
13.0	55.4	15.90
14.0	57.2	15.28
15.0	59.0	14.68
16.0	60.8	14.12
17.0	62.6	13.57
18.0	64.4	13.06
19.0	66.2	12.56
20.0	68.0	12.09
21.0	69.8	11.63
22.0	71.6	11.20
23.0	73.4	10.78
24.0	75.2	10.38
25.0	77.0	10.00
26.0	78.0	9.63
27.0	80.6	9.28
28.0	82.4	8.94
29.0	84.2	8.62
30.0	86.0	8.31
31.0	87.8	8.01

°C	°F	KΩ
32.0	89.6	7.72
33.0	91.4	7.45
34.0	93.2	7.19
35.0	95.0	6.94
36.0	96.8	6.69
37.0	98.6	6.46
38.0	100.4	6.24
39.0	102.2	6.03
40.0	104.0	5.82
41.0	105.8	5.63
42.0	107.6	5.43
43.0	109.4	5.25
44.0	111.2	5.08
45.0	113.0	4.91
46.0	114.8	4.74
47.0	116.6	4.59
48.0	118.4	4.44
49.0	120.2	4.30
50.0	122.0	4.16
51.0	123.8	4.02
52.0	125.6	3.90
53.0	127.4	3.77
54.0	129.2	3.65
55.0	131.0	3.53
56.0	132.8	3.42
57.0	134.6	3.31
58.0	136.4	3.21
59.0	138.2	3.11
60.0	140.0	3.02
61.0	141.8	2.92
62.0	143.6	2.83
63.0	145.4	2.75
64.0	147.2	2.66
65.0	149.0	2.58
66.0	150.8	2.51
67.0	152.6	2.43
68.0	154.4	2.36
69.0	156.2	2.29
70.0	158.0	2.22
71.0	159.8	2.16
72.0	161.6	2.10

°C	°F	KΩ
73.0	163.4	2.04
74.0	165.2	1.98
75.0	167.0	1.92
76.0	168.8	1.87
77.0	170.6	1.81
78.0	172.4	1.76
79.0	174.2	1.71
80.0	176.0	1.66
81.0	177.8	1.62
82.0	179.6	1.57
83.0	181.4	1.53
84.0	183.2	1.49
85.0	185.0	1.45
86.0	186.8	1.41
87.0	188.6	1.37
88.0	190.4	1.33
89.0	192.2	1.30
90.0	194.0	1.26
91.0	195.8	1.23
92.0	197.6	1.20
93.0	199.4	1.16
94.0	201.2	1.13
95.0	203.0	1.10
96.0	204.8	1.08
97.0	206.6	1.05
98.0	208.4	1.02
99.0	210.2	0.99
100.0	212.0	0.97
101.0	213.8	0.94
102.0	215.6	0.92
103.0	217.4	0.90
104.0	219.2	0.87
105.0	221.0	0.85
106.0	222.8	0.83
107.0	224.6	0.81
108.0	226.4	0.79
109.0	228.2	0.77
110.0	230.0	0.75











Note: Not all options are available on every model.

MODEL NUMBER	D	N	-	-	J									-	-							-	-		
DIGIT NUMBER	1	2	3	4	5	6	7	8	9	10	11	12	13	14	15	16	17	18	19	20	21	22	23	24	25

<b>Restrictions:</b>
<p>13: Heater Size Codes "5", "6", &amp; "7" are not available when Model Code is "DN-2-" and Heating Code is "G".</p> <p>14: Heater Size Codes "8" &amp; "9" are not available when Model Code is "DN-2-" or "DN-3-" and Heating Code is "G".</p> <p>15: Phase Code "1" is only available with Model Code "DN-2-".</p> <p>16: Heating Code "E" is not available with Phase Code "1".</p> <p>17: Some units with Customization Code "X" are not Safety Listed.</p> <p>18: SA Fan Location Code "A" is not available when no coils are selected.</p> <p>19: SA Fan Location Code "B" is not available when only coils are selected for Heating and Cooling and Orientation Codes are "B", "D", "F", "J", "K", "N", "P", or "V".</p> <p>20: Heating Codes "H" &amp; "S" are not available with Cooling Codes "H" or "P".</p>

### 15.6 CFM SCALING

The premium controller provides a reading of CFM along with control options to control fans to maintain a specific flow. In order for these features to work correctly it may be required to scale this value.

To do this, you would require a manometer to read the actual flow value. Compare it to this screen in *Unit Status*.

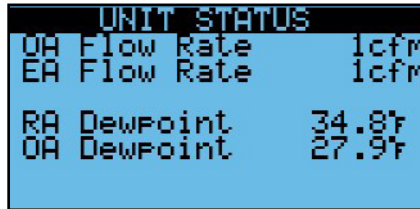

If it reads off, you can adjust the upper (10V) range on the following screen. Increasing that value will decrease the reading. Decreasing the value will increase the reading.

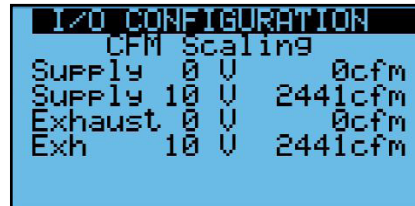

The factory set values are in this table.

UNIT MODEL	SUPPLY 10V	EXHAUST 10V
HE07	850	850
HE10	1100	1100
HE15	2450	2450
HE20	2780	2780
HE3X	3800	3800
HE4X	5520	5520
HE6X	7650	7650
HE7X	8215	8215
HE8X	8215	8215
LE5X	6258	6258
LE6X	9700	9700
LE8X	9170	9170
LE10X	11460	11460

The DN controller provides a reading of CFM along with control options to control fans to maintain a specific flow. In order for these features to work correctly it may be required to scale this value.

To do this, you would require a manometer to read the actual flow value. Compare it to this screen in *Unit Status*.

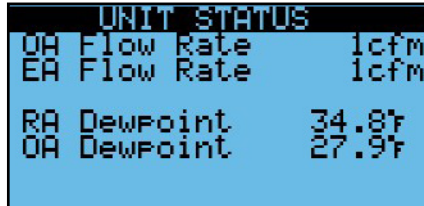

If it reads off, you can adjust the kfactor on the following screen. Increasing that value will increase the reading. Decreasing the value will decrease the reading.

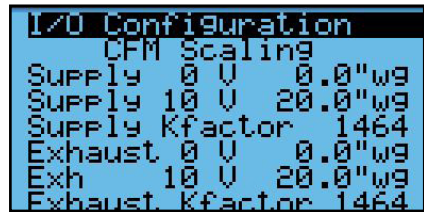

The factory set values are in this table.

VOLTAGE	HP/KW	RENEWAIRE PN	VENDOR	FAN SIZE	UNIT	K-FACTOR
P1 200-277V	1.35	136371	Ziehl-Abegg	GR31C	DN-2	1150
P3 200-240V	2.7	136372	Ziehl-Abegg	GR35C	DN-2, DN-3	1464
	2.7 x2	136372	Ziehl-Abegg	GR35C	DN-5	2928
P3 380-480V	3.7	136373	Ziehl-Abegg	GR31C	DN-2, DN-3	1150
	3.7 x2	136373	Ziehl-Abegg	GR31C	DN-5	2300
P3 208-240V	3	136352	Baldor	Punker 355 x 100	DN-2	1562
	5	136353	Baldor	Punker 355 x 100	DN-3	1562
	5 x2	136353	Baldor	Punker 355 x 100	DN-5	3124
P3 460V	3	136352	Baldor	Punker 355 x 100	DN-2	1562
	5	136353	Baldor	Punker 355 x 100	DN-3	1562
	5 x2	136353	Baldor	Punker 355 x 100	DN-5	3124
P3 575V	3	136314	Baldor	Punker 355 x 100	DN-2	1562
	5	136315	Baldor	Punker 355 x 100	DN-3	1562
	5 x2	136315	Baldor	Punker 355 x 100	DN-5	3124

## 16.0 GLOSSARY

### Analog Control Signal

An analog signal is a varying-voltage output signal, typically between 0–10 volts. It is most often used to produce a specific amount of output from a variable-output device, such as a digital scroll compressor or a variable speed fan. 0 volts would represent an OFF condition and 10 volts would represent a demand for output at 100% of capacity.

### BACnet

Building Automation Control Network. BACnet is a communications protocol for building automation and control networks. It is just one of several different control systems that may be used as part of a BMS.

### BACnet IP

### BACnet MSTP

BACnet Master Slave Token Passing—this is one of the possible BACnet protocols that may be used.

### BMS

A building management system (BMS) is a control system that can be used to monitor and manage the mechanical, electrical and electromechanical services in a facility. Such services can include power, heating, ventilation, air-conditioning, physical access control, pumping stations, elevators and lights.

### Cat-5 Cables

Cat-5 cable, sometimes called Ethernet cable, is short for Category 5 cable, a current industry standard for network wiring. This type of cable is unshielded wire containing four pairs of 24-gauge twisted copper pairs, terminating in an RJ-45 jack. If a wire is certified as Cat-5 and not just a twisted pair wire, it will have this designation printed on the outside.

### Controller

Direct Digital Control is the automated control of a condition or process by a digital device (computer). The controller accepts digital or analog inputs from a variety of sensors and then follows all of its programmed instructions to produce action instructions to valves, actuators, fans, compressors and other HVAC components that can be adjusted. The Carel controller is a DDC controller.

### Digital Control Signal

A digital control signal is a fixed-voltage or amperage output signal, representing either an “ON” or “OFF” condition for the device it is connected to. It is typically used to activate a relay that controls operation of a device.

### DIN Rail

A DIN rail is a specially shaped metal strip which is used to mount relays, switches, terminals, etc. in industrial panels. The shape of the strip is such that these items can be pressed onto it and a spring clip on each device slips into the bend in the rail and the device is held firmly. The strip can be mounted with screws or bolts to a wall or panel. The controller and any expansion boards are typically mounted on a DIN rail in the Main Control Panel.

### Economizer Bypass

The Economizer Bypass provides energy conservation during operation of an ERV. It accomplishes this by sensing ambient conditions and it then allows the return airstream or outdoor airstream to move through an alternate duct, bypassing the ERV enthalpic core when the unit calls for cooling and the outdoor conditions are more favorable than the return air.

### Ethernet

Ethernet is the standard way to connect computers on a network over a wired connection. It provides a simple interface and is used for connecting multiple devices, such as computers, routers, and switches. When the Carel controller is incorporated into a BMS, the BMS computer and the Carel controller become an ethernet.

### I/O Configuration

Refers to the specific wiring terminals on the controller that are assigned for each Input or OutputIP

### IP Address

A unique string of numbers separated by periods that identifies each computer using the Internet Protocol to communicate over a network

### Hot Gas Reheat (HGRH)

Used in dehumidification, hot gas reheat relies on an additional coil downstream of the cooling coil in which the hot refrigerant piping is in contact with the supply air. This allows a portion of the refrigerant cycle's rejected heat to be reclaimed as reheat. The amount of refrigerant piped to the coil is modulated to maintain a supply temperature during dehumidification.

### Hysteresis

The hysteresis is a value that is added to a setpoint for a specific control option to turn on, and then it turns off at setpoint. This helps prevent over cycling of the controlled device.

### I/O

Refers to all of the inputs and outputs such as sensors and control to fans.

### Modbus

Modbus is a serial communications protocol for use with programmable logic controllers (PLCs). It is a standard communication protocol, and it is now a commonly available means of connecting industrial electronic devices. Modbus enables communication among many devices connected to the same network, for example a system that measures temperature and humidity and communicates the results to a computer. Modbus is often used to connect a supervisory computer with a remote terminal unit (RTU) in supervisory control and data acquisition systems.

**Modbus RTU**—see Modbus, above.

**Modbus RTP**—see Modbus, above.

**NAND Memory**

NAND flash memory is a type of non-volatile storage technology that does not require power in order to retain data. The technology is used in common storage devices such as flash drives, solid-state drives and memory cards.

**NODE**

Any system or device connected to a network is also called a node. For example, if a network connects a file server, five computers, and two printers, there are eight nodes on the network. Each device on the network has a network address, such as a MAC address, which uniquely identifies each device.

**PI Control**

The output of PID controllers will change in response to a change in process variable or setpoint.

**RJ-45 jack**

RJ-45 is a standard type of connector for network cables. RJ-45 connectors are most commonly seen with ethernet cables and networks. RJ-45 connectors feature eight pins to which the wire strands of a cable interface electrically. Standard RJ-45 pinouts define the arrangement of the individual wires needed when attaching connectors to a cable. Several other kinds of connectors closely resemble RJ-45 and can be easily confused for each other.

**RUT**

Remote User Terminal. The RUT is the User Interface where a person can view current operating conditions or status, make changes to setpoints and otherwise control the operation of the air handler. The Carel RUT is an electronic device that has multiple push buttons and a viewing screen and is connected to the Carel Controller by means of a common telephone cable.

**Setpoint**

The desired value in a closed-loop feedback system, as in regulation of temperature or pressure.

**USB/USB Port**

Universal Serial Bus. There are different types of USB ports that are commonly used. Type “A” ports are almost always found on computers and are used to connect with other electronic devices. The Carel c.pCO Mini has a Micro USB type “B” that is used to connect to external memory devices or to a computer.

**USB Thumb Drive**

A very small, portable, solid-state hard drive that can be inserted into a USB port for storage and retrieval of data.

**UI**

User Interface—commonly called “UI.” A user interface is the means by which a person controls a hardware device or a software application. For the Carel Controller, the RUT (Remote User Terminal) is one possible User Interface.

**URL**

Uniform Resource Locator. Commonly referred to as a web address. It is a very specific address that identifies the location of a specific website or address on the internet.

**Wipe Retain**

Wipe/Retain is a user-commanded function in which all non-volatile memory in the Controller is erased and factory defaults are reinstalled.



## About RenewAire

For over 40 years, **RenewAire has been a pioneer in enhancing indoor air quality (IAQ)** in commercial and residential buildings of every size. This is achieved while maximizing sustainability through our fifth-generation, static-plate, enthalpic-core **Energy Recovery Ventilators (ERVs) that optimize energy efficiency**, lower capital costs via load reduction and decrease operational expenses by minimizing equipment needs, resulting in significant energy savings. Our ERVs are competitively priced, simple to install, easy to use and maintain and have a quick payback. They also enjoy the industry's best warranty with the lowest claims due to long-term reliability derived from innovative design practices, expert workmanship and **Quick Response Manufacturing (QRM)**.

As the pioneer of static-plate core technology in North America, RenewAire is the largest ERV producer in the USA. We're **committed to sustainable manufacturing** and lessening our environmental footprint, and to that end our Waunakee, WI plant is 100% powered by wind turbines. The facility is also one of the few buildings worldwide to be LEED® Gold and Green Globes certified, as well as having achieved ENERGY STAR Building status. In 2010, RenewAire joined the Soler & Palau (S&P) Ventilation Group in order to provide direct access to the latest in energy-efficient air-moving technologies. For more information, visit: [renewaire.com](http://renewaire.com)

201 Raemisch Road | Waunakee, WI | 53597 | 800.627.4499 | [RenewAire.com](http://RenewAire.com)