

FACTORY-INSTALLED SM VECTOR VARIABLE FREQUENCY DRIVES IN RENEWAIRE UNITS

Supplemental Manual for Options

FOR COMMERCIAL UNITS



LENZE AC TECH VFD SHOWN



VFD KEYPADS IN E-BOX

⚠ WARNING

RISK OF FIRE, ELECTRIC SHOCK, OR INJURY.
OBSERVE ALL CODES AND THE FOLLOWING:

1. Before servicing or cleaning the unit, switch power off at disconnect switch or service panel and lock-out/tag-out to prevent power from being switched on accidentally. More than one disconnect switch may be required to de-energize the equipment for servicing.
2. This installation manual shows the suggested installation method. Additional measures may be required by local codes and standards.
3. Installation work and electrical wiring must be done by qualified professional(s) in accordance with all applicable codes, standards and licensing requirements.
4. Any structural alterations necessary for installation must comply with all applicable building, health, and safety code requirements.
5. This unit must be grounded.
6. Use the unit only in the manner intended by the manufacturer. If you have questions, contact the manufacturer.
7. When cutting or drilling into unit, wall or ceiling, do not damage electrical wiring and other hidden utilities.
8. Do not re-wire the VFD(s) to control more than one motor per VFD.
9. Do not operate the motors in this unit above the motor's rated full load amps (FLA) as indicated on the unit's nameplate. Follow all local codes.

⚠ WARNING**Capacitors in VFDs Retain Charge**

Allow 3 minutes after shutting off power to the VFDs to allow the capacitors in the VFD to fully discharge. Do not connect or disconnect wires at the VFD without waiting 3 minutes.

⚠ CAUTION

DO NOT OPERATE VFD IN CONDITIONS OUTSIDE OF TEMPERATURE LIMITS. The manufacturer's ambient temperature limits for the VFDs are 14–131°F. It is not recommended that the VFDs be used under conditions above or below these temperature limits. Operate outdoor ERV units continuously if outdoor design conditions are not within the VFD operating temperature range or make other provisions to bring the VFD operating condition into the acceptable ambient temperature range. RenewAire commercial ERVs are VFD ready, in extreme climates consider field installing VFDs in a climate controlled indoor electrical cabinet.

1.0 OVERVIEW 4

1.1 ABOUT SM VECTOR VARIABLE FREQUENCY DRIVES (VFDS)4

1.2 PLANNING YOUR INSTALLATION4

1.2.1 “ON” and “SPEED” Signals 5

1.2.2 Principles of External Control 5

1.2.3 Connecting External Controls 5

1.2.4 Wire Routing..... 5

1.2.5 Purpose of Providing Keypad..... 6

2.0 INSTALLATION 7

2.1 WIRING OPTIONS.....7

2.1.1 “ON” Signal Connections..... 7

2.2 WIRING SCHEMATICS.....7

2.2.1 Analog Inputs to Provide the “SPEED” Signal..... 9

2.2.2 Wiring Two VFDs for Leader-Follower Operation 9

2.2.3 Using VFD Presets for the “SPEED” Signals.....10

2.2.4 Use with a CO2 Controller11

3.0 OPERATION 12

3.1 INSTALLATION INSTRUCTION12

3.1.1 Use with a Building Management System12

3.2 INITIAL START-UP12

3.2.1 To Start ERV12

3.3 SETTINGS.....13

3.3.1 VFD Parameter Overview13

3.3.4 Summary Table of Commonly Used Parameters.....14

3.3.5 Scaling and Response to Analog Inputs15

3.3.8 Examples of VFD Scaling18

4.0 FACTORY ASSISTANCE 19

TABLE OF ILLUSTRATIONS

Figure 1.2.0 SM Vector Keypad Buttons..... 6

Figure 2.2.0 Connection of “ON” Signals to Low-Voltage Terminal Strip in ERV E-box7

Figure 2.2.1 Factory Control Wiring: ON Signals Connected to Each VFD 8

Figure 2.2.2 Alternate Control Wiring 8

Figure 2.2.3 Examples of Analog Input Connections 9

Figure 2.2.4 Leader-Follower Connection 9

Figure 2.2.5 Use of 3 Switches to Command the VFD to Operate at Any of 3 Pre-set Speeds (SP4T Switch Alternatively)..... 10

Figure 2.2.6 Example of Operation of 2 VFDs by a CO2 Controller 11

1.0 OVERVIEW

1.1 ABOUT SM VECTOR VARIABLE FREQUENCY DRIVES (VFDS)

This manual supplements RenewAire's standard Installation & Operation Manuals, which do not include information on units equipped with SM Vector VFDs. RenewAire uses SM Vector VFDs for some models, typically those using a 575VAC power supply when the VFD option is selected.

When the unit includes Enhanced or Premium Integrated Programmable Controls, all wiring and VFD parameters are preset and should not be changed unless instructed to do so by TSS. In units where the controls are not provided, follow these instructions to integrate the VFDs into your control strategy.

For complete ERV installation you will also need:

- **Standard Installation and Operation Manual for the ERV**—physical installation and duct connection, maintenance procedures, etc.
- **Supplemental Wiring Schematic Manual**—complete unit wiring diagrams.
- **SM Vector-Frequency Inverter Operating Instructions**—Lenze AC Tech's users/installers manual.
More information is available online in the Technical Library at www.lenze-actech.com.
- **SM2 Series Flux Vector Installation and Operation Manual**—Leeson's users/installers manual.
More information is available online at www.regalrexnord.com.

1.2 PLANNING YOUR INSTALLATION

⚠ WARNING

RISK OF FIRE, ELECTRIC SHOCK, OR INJURY.
OBSERVE ALL CODES AND THE FOLLOWING:

1. Before servicing or cleaning the unit, switch power off at disconnect switch or service panel and lock-out/tag-out to prevent power from being switched on accidentally. More than one disconnect switch may be required to de-energize the equipment for servicing.
2. This installation manual shows the suggested installation method. Additional measures may be required by local codes and standards.
3. Installation work and electrical wiring must be done by qualified professional(s) in accordance with all applicable codes, standards and licensing requirements.
4. Any structural alterations necessary for installation must comply with all applicable building, health, and safety code requirements.
5. This unit must be grounded.
6. Use the unit only in the manner intended by the manufacturer. If you have questions, contact the manufacturer.
7. When cutting or drilling into unit, wall or ceiling, do not damage electrical wiring and other hidden utilities.
8. Do not re-wire the VFD(s) to control more than one motor per VFD.
9. Do not operate the motors in this unit above the motor's rated full load amps (FLA) as indicated on the unit's nameplate. Follow all local codes.

⚠ CAUTION

DO NOT OPERATE VFD IN CONDITIONS OUTSIDE OF TEMPERATURE LIMITS. The manufacturer's ambient temperature limits for the VFDs are 14–131°F. It is not recommended that the VFDs be used under conditions above or below these temperature limits. Operate outdoor ERV units continuously if outdoor design conditions are not within the VFD operating temperature range or make other provisions to bring the VFD operating condition into the acceptable ambient temperature range. RenewAire commercial ERVs are VFD ready, in extreme climates consider field installing VFDs in a climate controlled indoor electrical cabinet.



NOTE: VFD(s) in this unit can be operated in many ways. This Manual provides only an outline of common methods.

1.2.1 “ON” and “SPEED” Signals

VFD operation in this unit is dependent on two signals: an “ON” signal and a “SPEED” (or REFERENCE) signal. The sources and types of these signals can vary. If the ERV is equipped with dampers the “ON” signal to the VFD comes from the end switch on the damper. If the ERV is not equipped with dampers, the “ON” signal comes from an external control connected directly to the VFD. When an “ON” signal is received by the VFD, it starts the motor. The VFD then operates the blower at the speed established by the “SPEED” signal. The “SPEED” signal is often provided by an external control, but in some applications “pre-set” speeds are set inside the VFD and are selected by external switches or relays.

1.2.2 Principles of External Control

This ERV can be operated by various external control devices including remote switch or relay, digital time clock with relay, occupancy sensor with relay, and carbon dioxide sensor with relay and analog output. These devices are commonly known as 2-wire, 3-wire, and 4-wire devices. A Building Management System (BMS) can control this ERV through relay contacts and with 0–10vdc or 4–20mA analog inputs.

The external control devices can be connected to this ERV to operate each blower independently **or**

for one blower to act as leader and the other blower to act as follower. In leader-follower mode, a single external switch or relay calls for operation and the leader VFD sets “SPEED” to internal presets, or in response to an analog input signal. The follower VFD then operates at either exactly the same speed, at an offset above or below the leader’s speed, or at a scaled speed.

The VFD’s are pre-programmed at the factory so only a few parameters need change for a specific installation.

1.2.3 Connecting External Controls

If this ERV is equipped with damper(s), the “ON” signal is connected to the terminal strip in the electrical enclosure (E-box). If this ERV is not equipped with damper(s), and has 2 VFDs, the “ON” signal is connected directly to the VFDs. The SPEED” signals are always connected directly to the VFD(s).

1.2.4 Wire Routing

Route input power cables, motor cables and control cables separately to decrease electromagnetic interference caused by the rapid changes in the drive output voltage. Where control cables must cross power cables make sure that they are arranged at an angle as near to 90 degrees as possible.

Power cables and control cables can be brought into the bottom of the e-box attached to the ERV unit or through the bottom of the unit itself. There are plugged holes to run control wires and power wires between the electrical box and the unit interior, marked on the interior of the ERV unit and another plugged hole in the unit compartment divider to run wires to VFDs in the other airstream compartment if needed.

In some configurations the VFD and/or VFD protective guard may need to be removed to access the control wire hole plug to run wires. A label is located in the ERV on the left interior wall indicating the power and control wire hole plug locations. Bring wires out from the top or bottom of the VFD mounting bracket and not through the mounting bracket window when routing wires if the VFD is mounted over the hole plug.

After the wires are run, apply caulk around the wires at wire bushings used between the electrical box and ERV unit and between compartments in the unit to prevent air leakage between these compartments.

1.2.5 Purpose of Providing Keypad

Each VFD has a keypad which is accessible at the e-box while the unit is operating.

You can check the status of the VFD at the keypad, and make changes to the VFD parameters at the keypad. You can manually control the VFD from the keypad during start-up and commissioning.

VFD is factory programmed to cover most needs but some parameters will need to be set to interact with the external control system.

Access the keypad(s) through the removable cover to the e-box.

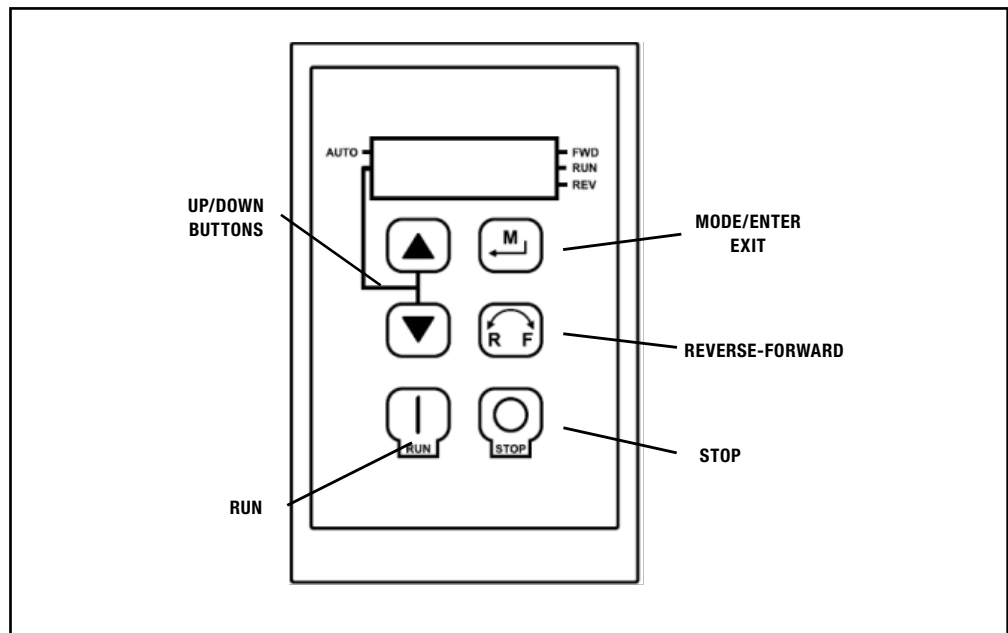

FIGURE 1.2.0 SM VECTOR KEYPAD BUTTONS

2.0 INSTALLATION

2.1 WIRING OPTIONS

2.1.1 "ON" Signal Connections

Depending on features installed, connect ON-SIGNAL connections either to the VFDs themselves, or to the low-voltage terminal strip in the ERV e-box. See schematics below.

Install a jumper between terminals 2 and 3 to use the ERV's on-board 24VAC power. Do this when the external control(s) have isolated contacts that don't provide any voltage, as in the top two examples. Make no connections between terminals 1 & 2 and terminals 3-5 if the external control has a voltage output to provide the "ON" signal. This voltage must be 24VAC.

⚠ WARNING

Capacitors in VFDs Retain Charge

Allow 3 minutes after shutting off power to the VFDs to allow the capacitors in the VFD to fully discharge. Do not connect or disconnect wires at the VFD without waiting 3 minutes.

2.2 WIRING SCHEMATICS

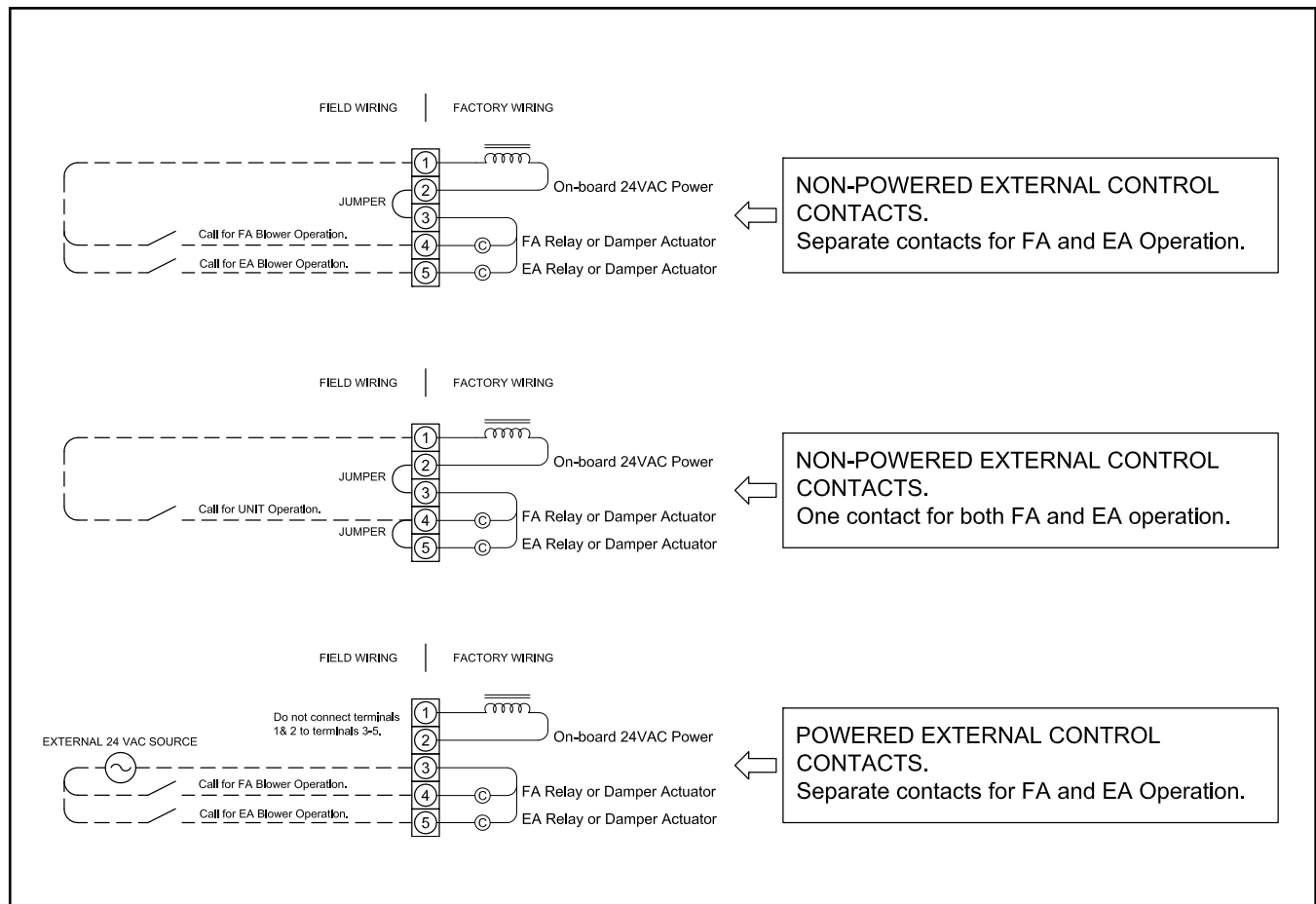

FIGURE 2.2.0 CONNECTION OF "ON" SIGNALS TO LOW-VOLTAGE TERMINAL STRIP IN ERV E-BOX

See Figure 2.2.0 for Relay or Damper Actuator Connection alternatives.

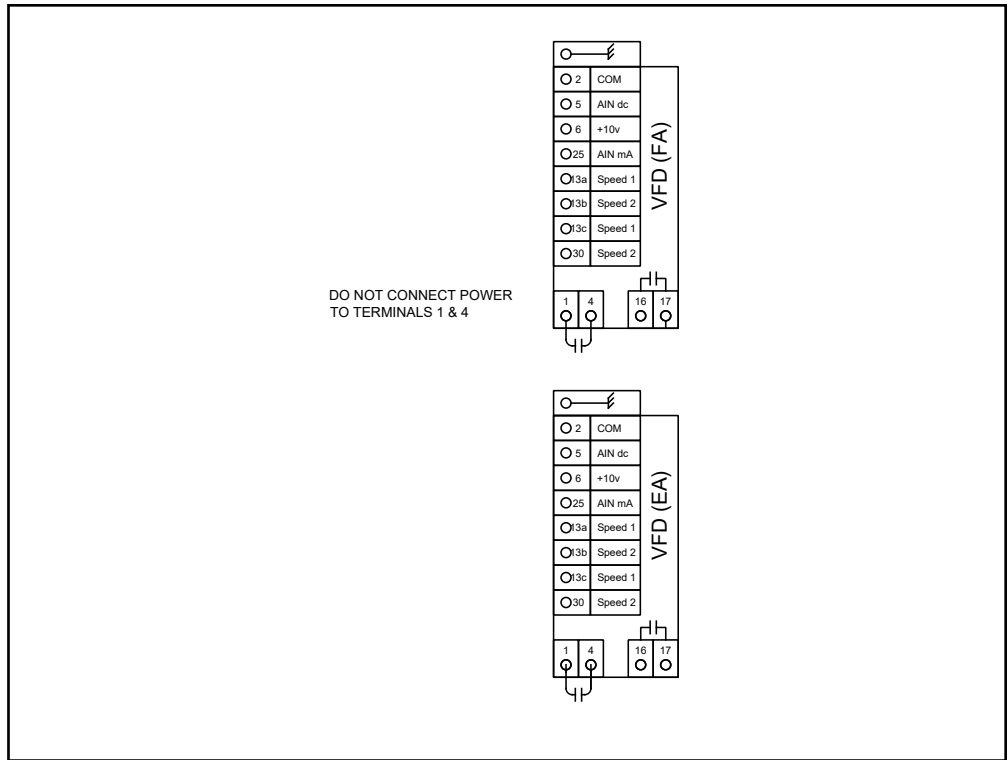
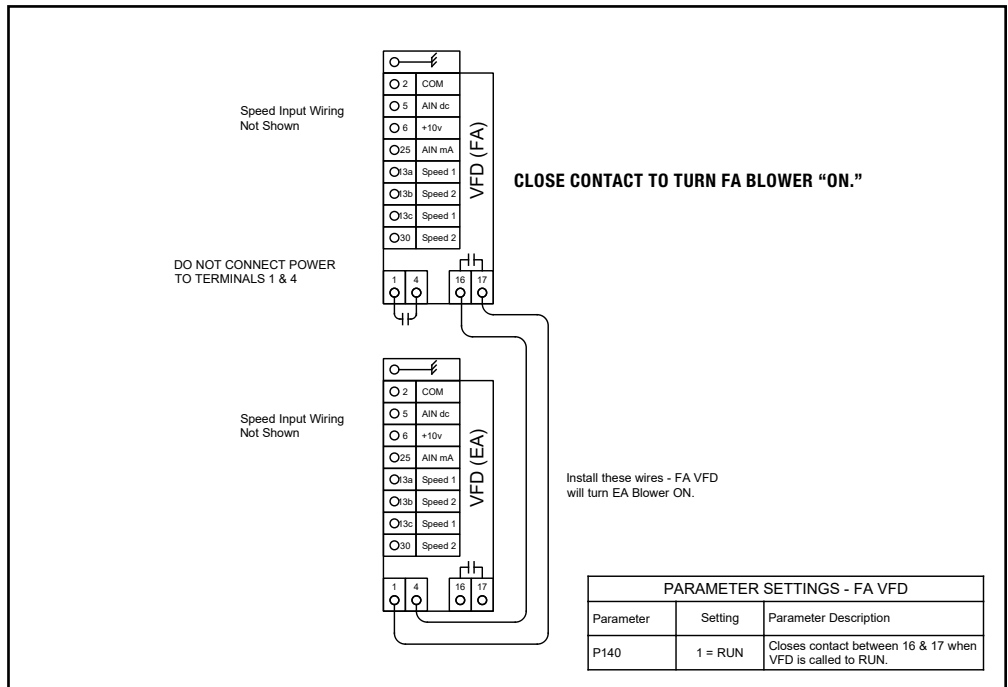

FIGURE 2.2.1 FACTORY CONTROL WIRING: ON SIGNALS CONNECTED TO EACH VFD

Alternative Control Wiring: "ON" signal connected directly to one VFD, passed to second VFD from terminals 16 & 17.



PARAMETER SETTINGS - FA VFD		
Parameter	Setting	Parameter Description
P140	1 = RUN	Closes contact between 16 & 17 when VFD is called to RUN.

FIGURE 2.2.2 ALTERNATE CONTROL WIRING

2.2.1 Analog Inputs to Provide the “SPEED” Signal

Analog inputs are connected as shown below. It may be necessary to scale the response of the VFD to the analog “SPEED” signal.

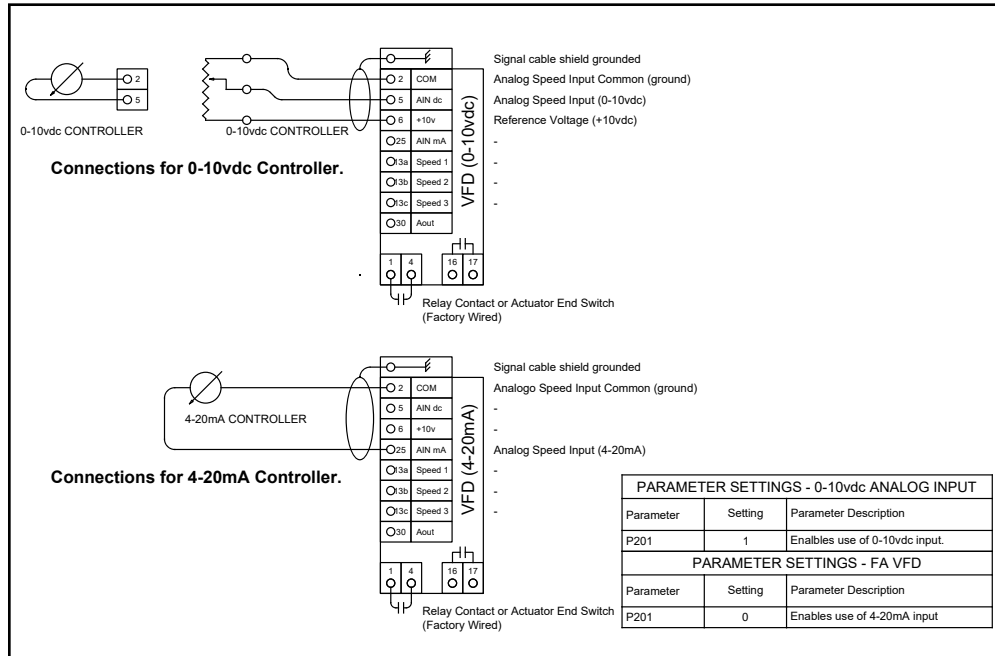

FIGURE 2.2.3 EXAMPLES OF ANALOG INPUT CONNECTIONS

2.2.2 Wiring Two VFDs for Leader-Follower Operation

One VFD can provide the “SPEED” signal to a second VFD, as shown below.

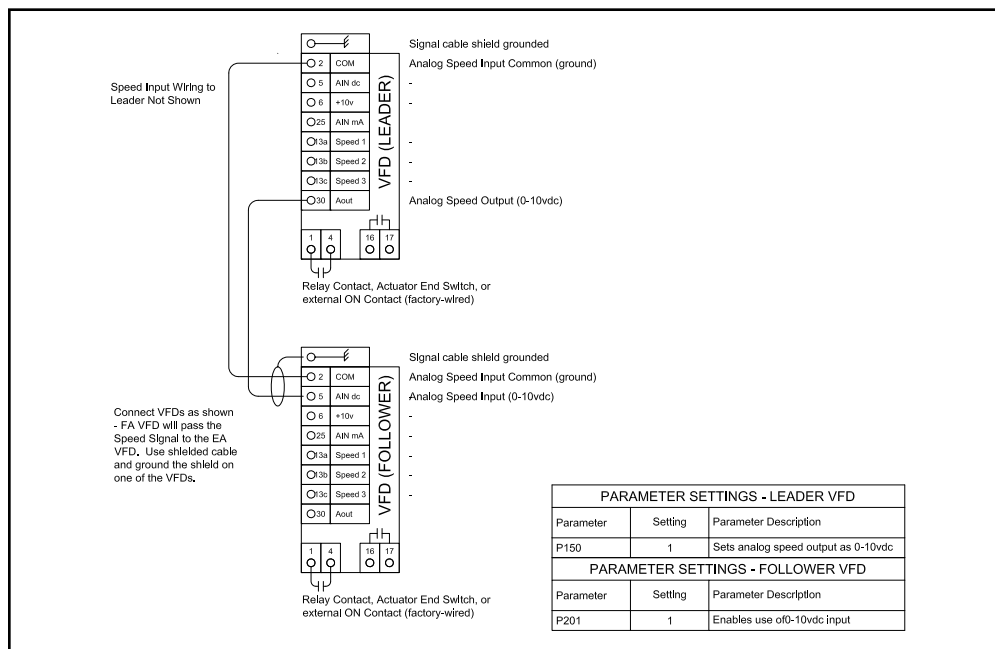

FIGURE 2.2.4 LEADER-FOLLOWER CONNECTION

NOTE: All wiring for analog signals connected to the VFDs should be double- or single-shielded twisted-pair cable. Ground the shield at one end of the cable only. The grounding clamp on the VFD may be used.

NOTE: If the FA VFD is controlled by an analog input signal, it is likely that the FA VFD’s response to the analog input will need to be scaled. See “SM Vector – Frequency Inverter Operating Instructions” – Lenze/AC Tech’s user’s/installer’s manual or “SM2 Series Flux Vector Installation and Operation Manual”—Leeson’s users/installers manual.

Parameter P152 TB-30 Scaling Frequency can be used to scale the Analog Output of the Leader VFD in order to offset or correct the speed of the Follower VFD.

If both VFDs are to run at the same speed, no scaling parameters need be applied to the EA VFD since it is controlled as a “Follower.”

2.2.3 Using VFD Presets for the “SPEED” Signals

The VFD can be programmed with 3 pre-set speeds. Switches can then be used to direct the VFD to operate at one of those speeds. See SM Vector manuals for additional options. Leader-follower wiring can also be used to make a second VFD operate at the same speed as the first VFD.

NOTE: Pre-set speeds override any Frequency (Speed) inputs.

Install Leader-Follower connection wiring if desired to operate second VFD at the same speeds.

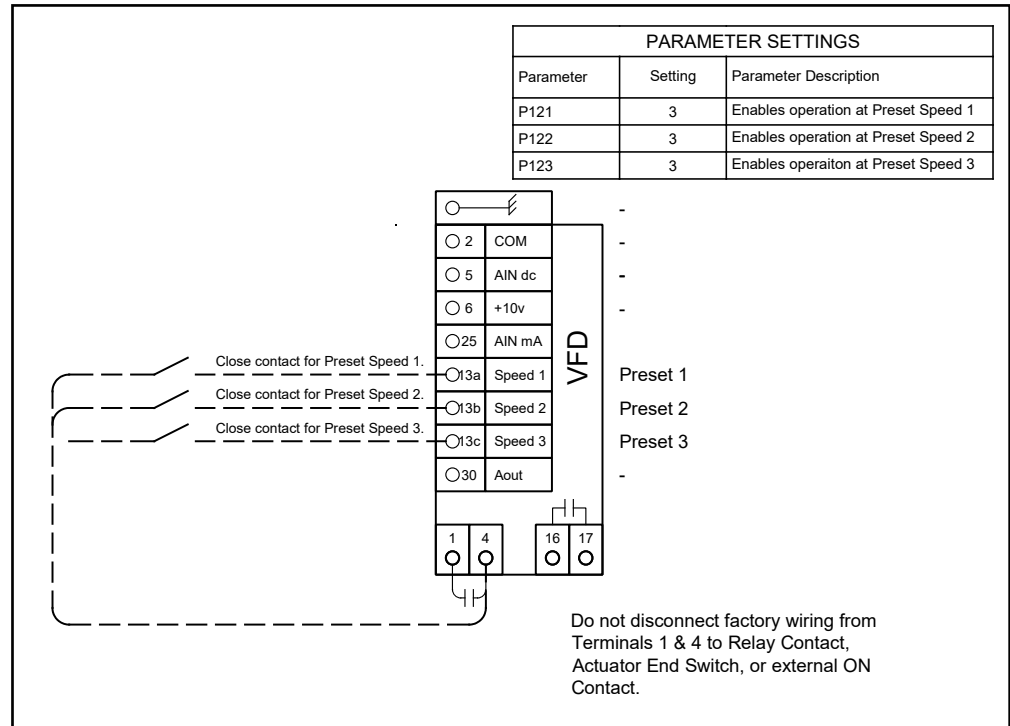

FIGURE 2.2.5 USE OF 3 SWITCHES TO COMMAND THE VFD TO OPERATE AT ANY OF 3 PRE-SET SPEEDS (SP4T SWITCH ALTERNATIVELY)

The desired preset speeds are set at Parameters P131-P133. AC Tech allows up to 7 presets. Values as shipped from factory are shown below:

PARAMETERS	VALUE AS SHIPPED FROM RENEWAIRE	PARAMETER DESCRIPTION
P131	30 Hz	Preset Speed #1
P132	45 Hz	Preset Speed #2
P133	60 Hz	Preset Speed #3

2.2.4 Use with a CO2 Controller

If both VFDs are to run at the same speed, no scaling parameters need be applied to the EA VFD in this example since it is controlled as a "Follower." If it is required that the VFDs shut off when CO2 levels drop below a setpoint, connect the Normally Open contacts of the CO2 controller (terminals 3 & 4) to terminals 1 & 4 of the FA VFD. Adjust the operating parameters of the CO2 controller to set the relay setpoint.

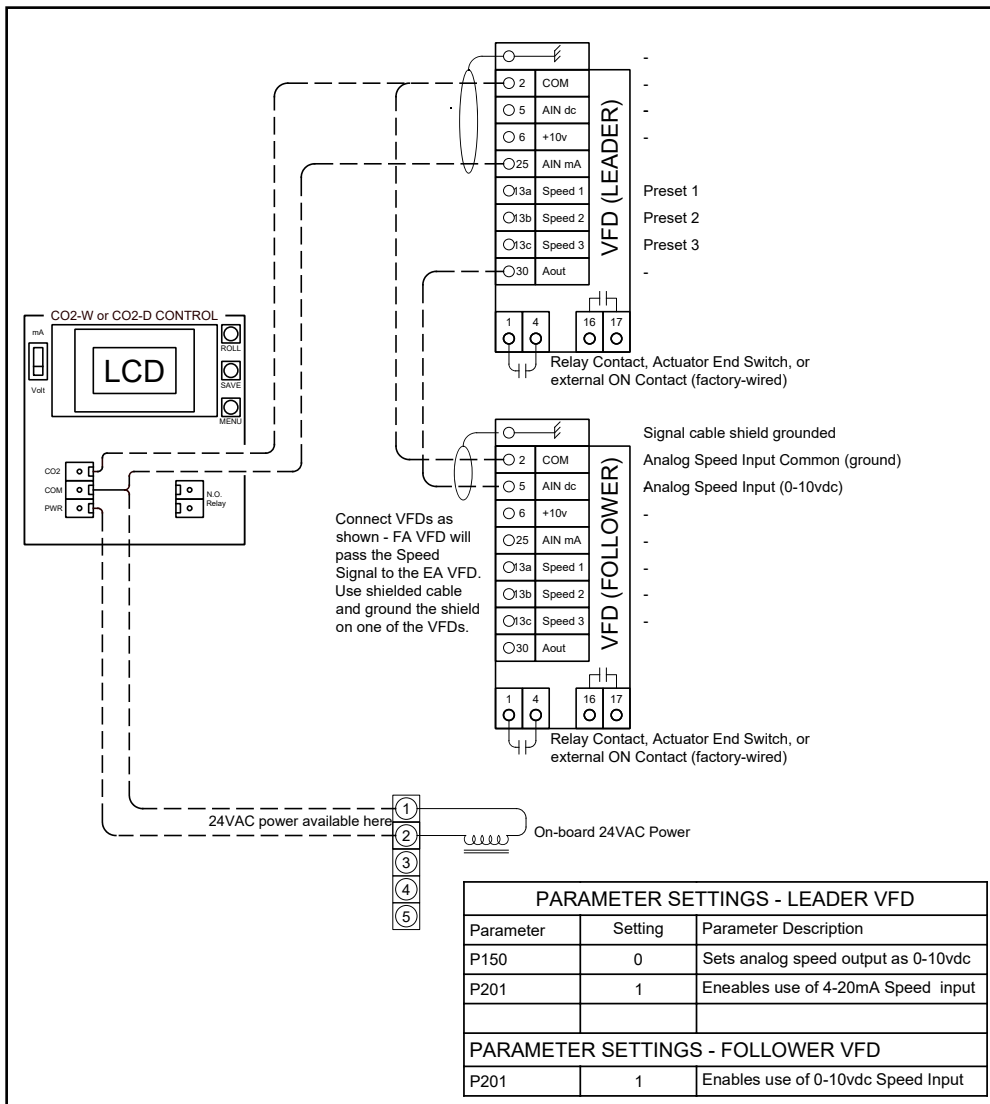

FIGURE 2.2.6 EXAMPLE OF OPERATION OF 2 VFDs BY A CO2 CONTROLLER

3.0 OPERATION

3.1 INSTALLATION INSTRUCTION

3.1.1 Use with a Building Management System

The SM Vector drive can be connected to an external control system. The drive supports Modbus RTU, CANopen®, DeviceNet®, Ethernet, Profibus® and Lecom-B® Protocols. An I/O Module can also be installed. The SM Vector drive can be upgraded in the field with communication modules sold by others. They snap into the drive terminal cover and are ready to connect to the network. See the SM Vector Drives User's Manual for details on connecting to an external control system.

3.2 INITIAL START-UP

3.2.1 To Start ERV

1. Turn off power to the ERV at its Disconnect Switch.

Make sure the ERV is wired to provide an "ON" signal. (See Control Wiring Schematics later in this Manual.) You may need to install a temporary jumper at the ERV or VFD low-voltage terminal strip. VFDs are set at the factory to respond to the keypad. If an external controller providing an analog input is connected to the VFD, you may want to temporarily disconnect it. Close ERV doors and main cover for the E-box; leave keypads accessible.

2. Turn on power to the ERV at its Disconnect Switch.

Wait for keypad display to appear.

3. For each VFD:

Press the RUN button on the keypad. Motor should start running at about 425 RPM.

Use the UP/DOWN buttons to set motor speed as desired. Confirm the motor amps are no greater than the motor FLA as listed on the unit nameplate using parameter P508 (see section on how to view VFD parameters).

4. To transfer control of the VFD to a control system:

Press the "STOP" button on the keypad. Motor should stop running.

Change the VFD parameters as required for the specific controls system (see "Control Connections" and "VFD parameters," below, for examples; see also the SM Vector Manuals.)

3.2.2 Motor Protection by the VFD(s)

Each VFD in this unit protects one motor against overload. It is critical that the VFD Motor Overload be properly set using the Full Load Amps (FLA) of the motor. The following Parameter must be set correctly and individually for each VFD to match the characteristics of the motor attached to it:

P108 MOTOR OVERLOAD = motor FLA/VFD output rating x 100% P165 BASE VOLTAGE

These parameters are set at RenewAire to match the motor controlled by the VFD. In most cases they should not be changed.

3.3 SETTINGS

3.3.1 VFD Parameter Overview

“VFD Parameters” are instructions that the Variable Frequency Drives follow. They can be adjusted by using the keypads on the VFDs. In some control configurations, they will need to be changed from the settings as shipped in the unit to interface with your control system.

3.3.2 To View All VFD Parameters

VFD must be powered up—something will be showing on the LED display.

1. Push “MODE” button—“PASS” will flash on screen followed by “0000.”
2. Push “MODE” button again to display P498.
3. Use “UP” or “DOWN” arrows to scroll through the Parameters.
4. Press “MODE” button to display the Parameter value.
5. Press “MODE” to exit—“STOP” will display.
6. To view other parameters start process over.

3.3.3 To Change VFD Parameters

VFD must be powered up—something will be showing on the LED display.

IF PASS CODE is enabled (i.e. P194 is set to something other than “0”):

1. Push “MODE” button—“PASS” will flash on screen followed by “0000.”
2. Press and hold “UP” Button to scroll to password “225.”
3. Press “MODE;” P100 will be displayed.
4. Proceed to step 6, below.

If PASS CODE is NOT enabled (i.e. P194 is set to “0”):

5. Press “MODE” button; the last-viewed Parameter will be displayed.
6. Use “UP” or “DOWN” Button to scroll to Parameter of interest.
7. Press “MODE” Button; Parameter value will be displayed.
8. Use Up/Down Arrow button to change parameter value.
9. Press “MODE” button to save changed parameter value.
10. Press “MODE” button to exit; “STOP” will be displayed (in some cases the display will be different).

3.3.4 Summary Table of Commonly Used Parameters

	NAME/SELECTION	DEFAULT	VALUE AS SHIPPED FROM RENEWAIRE	FUNCTION
P100	Start Control Source	0	2 without integrated programmable controls, 1 with integrated programmable controls	2 = Sets the source of the "START command is the keypad in the unit e-box. Change to 1 = Terminal Strip to enable on/off controls connected to terminal strip.
P101	Standard Reference Source	0	0 without integrated programmable controls, 1 with integrated programmable controls	1 = Enables 0–10vdc input to VFD. 2 = Enables 4–20mA input to VFD.
P102	Minimum Frequency (Hz)	0	15	Determines the minimum operating speed for the blower.
P103	Maximum Frequency (Hz)	60	60, 90, or 120 motor dependent (90 Hz LE units)*	Determines the maximum operating speed for the blower.
P104	Acceleration Time 1 (sec)	20	20	Blower Speed Acceleration Time
P105	Deceleration Time 1 (sec)	20	20	Blower Speed Deceleration Time
P108	Motor Overload	100	Set per motor	CRITICAL SAFETY PARAMETER P108 = Motor FLA / VFD Output Amp Rating X 100
P121	TB-13A	0	0	Determines what action the VFD takes when a TB-13x is shorted to terminal 4. Setting "0" means VFD ignores these terminals. Change to "3" to enable use of Preset Speeds.
P122	TB-13B	0	0	
P123	TB-13C	0	0	
P131	Preset Speed #1 (Hz)	0	30	Determines VFD speed when the Preset is selected. Parameter value equals operating speed in hertz.
P132	Preset Speed #2 (Hz)	0	45	
P133	Preset Speed #3 (Hz)	0	60	
P140	Relay Output, TB-16, TB-17	0	1	"1" enables the output. "0" disables the output.
P150	TB-30 Output	0	1	Determines what the 0-10VDC or 4-20mA signal available at Terminal 30 indicates VFD Frequency, Load, Torque or Power. "0" = disables all output from Terminal 30. "1" = enables 0–10VDC Frequency Output "2" =enables 4–20mA Frequency Output.
P152	TB-30 Scaling: Frequency	60	60 (Hz)	Can be used to scale the analog signal at TB-30.
P160	Speed at Minimum Signal	0	0 (Hz)	When analog input is used to control VFD speed, sets VFD speed in hertz when analog signal is 0%.
P161	Speed at Maximum Signal	60	60, 90, or 120 (Hz) motor dependent	When analog input is used to control VFD speed, sets VFD speed in hertz when analog signal is 100%.
P165	Base Voltage	--	575V	Must equal motor nameplate voltage
P194	PASSWORD	0	Enter "225" and cycle power to lock VFD from parameter changes and display PASS 0000	"0" = password disabled and VFD is unlocked. Must enter "225" to unlock and make changes to parameters if locked. PASS 0000 will show on screen when attempting parameter change if locked.
P400	Network Protocol	0	1	"1" = Remote Keypad

*Maximum Frequency set higher in LE units to generally operate motors near 60 Hz or faster, resulting in higher motor output HP.

3.3.5 Scaling and Response to Analog Inputs

The most likely reason to control the VFD from an analog signal is automatically change the amount of outside air ventilation to meet the actual needs for each time period.

If one or both of the VFDs will be controlled by an analog input from an external Control Device (e.g. a CO2 controller or a Building Management System), you may need to “scale” the rate of response of the VFD(s) to the rate of change of the analog signal. Usually only one of the two VFDs requires scaling.

We need to introduce two concepts relating to the amount of outside air ventilation needed in the building:

- ♦ The “ACTION LEVEL” (AL) is the level of measurement of indoor air quality or occupancy at which the ERV Unit should start to deliver more than the “Design Minimum Supply Airflow;”
- ♦ The “MAXIMUM RESPONSE LEVEL” (MRL) is the level of measurement of indoor air quality or occupancy at which the ERV Unit should be operating at the “Design Maximum Supply Airflow.”

3.3.6 Additional Job Information Needed

1. **Input Type (IT)** of analog signal: VDC or mA
2. **Minimum Signal Value (MinSV)** of the analog signal: e.g. 0VDC or 4mA.
3. **Maximum Signal Value (MaxSV)** of the analog signal: e.g. 10VDC, 20mA
4. **Measurement Range (MR)**: the range of the values that can be measured by the Control Device (e.g. a controller set to measure CO2 from 0ppm to 1100ppm).
5. **Action Level Signal (ALS)**: the value of the analog signal corresponding to the “Action Level.”
6. **Maximum Response Level Signal (MRLS)**: the value of the analog signal corresponding to the “Maximum Response Level.”
7. **Maximum Hertz (MaxH)**: VFD frequency setting at maximum design airflow. This was determined during the initial balancing process.
8. **Minimum Hertz (MinH)**: setting corresponding to minimum design airflow, again determined during the initial balancing process.
9. Whether ventilation should stop whenever air quality is below the “Action Level,” or should continue at minimum design airflow.

3.3.7 Application Example: CO2 Controller

Consider the following building provided with outside air ventilation by an ERV Unit:

- ♦ The engineer requires a minimum outside air ventilation rate of 700 CFM at all times in order to control the level of indoor air pollutants generated by the furnishings.
- ♦ To address the higher level of ventilation required when the building is occupied, the engineer specifies that a CO2 controller shall be used to increase ventilation if CO2 levels rise above 600ppm.
- ♦ The engineer specifies a maximum outside air ventilation rate of 1500 CFM and expects this to restrain CO2 levels to 1000ppm.

In short, the ventilation requirements call for the ERV Unit to be running at no less than 700CFM at all times. When CO2 levels increase above 600ppm, the airflow volume should increase, reaching a maximum of 1500CFM at a CO2 level of 1000ppm.

Turning to the equipment itself:

- The CO2 controller is set up to deliver a linear 0–10vdc signal over a measurement range of 0–1100ppm.
Therefore: the “INPUT TYPE” (IT) = VDC.
The Minimum Signal Value (MinSV) = 0VDC.
The Maximum Signal Value (MaxSV) = 10VDC.
The Measurement Range (MR) = 0–1100ppm.
- During Balancing we recorded VFD frequencies of 50hz at 1500 CFM, and 20hz at 700CFM.
Therefore: “Maximum Hertz (MaxH) = 50.
“Minimum Hertz” (MinH) = 20.
- From the engineer’s requirements:
the “Action Level” = 600ppm;
the “Maximum Response Level” = 1000ppm.

We must calculate the Action Level Signals (ALS), the value of the analog signal coming from the controller when CO2 = 600ppm:

$$ALS = MinSV + \left[\frac{ACTION_LEVEL}{MR} \times MaxSV \right]$$

Or, in this example:

$$ALS(VDC) = 0(VDC) + \left[\frac{600(ppm)}{1100(ppm)} \times 10(VDC) \right] = 5.5(VDC)$$

We must calculate the Maximum Response Level Signal (MRLS): the value of the analog signal coming from the controller when CO2 = 1000ppm:

$$MRLS = MinSV + \left[\frac{MRL}{MR} \times MaxSV \right]$$

Or, in this example:

$$MRLS(VDC) = 0(VDC) + \left[\frac{1000(ppm)}{1100(ppm)} \times 10(VDC) \right] = 9.1(VDC)$$

Now we can set the VFD parameters that will scale the response of the VFD to the inputs from the CO2 controller (see table on page 15):

Set Parameter 101 Standard Reference Source to “1,” telling the VFD to expect a 0–10VDC signal.

Set Parameter 102 Minimum Hertz: to “20.” The VFD will never operate the motors below this speed.

Set Parameter 103 Maximum Hertz to “50.” The VFD will never operate the motors above this speed.

Set Parameter 160 Speed at Minimum Signal to the following calculated value:

$$P160 = P102 - \left[\frac{P103 - P102}{MRLS - ALS} \times (ALS - MinSV) \right]$$

Or, in this example:

$$P160(\text{hz}) = 20(\text{hz}) - \left[\frac{(50 - 20)(\text{hz})}{(9.1 - 5.5)(\text{VDC})} \times (5.5(\text{VDC}) - 0(\text{VDC})) \right] = -25.8(\text{hz})$$

Do not be concerned if this P160 is a negative number or is lower than the desired minimum—Parameter 102 will maintain VFD speed above this level.

Set Parameter 161 Speed at Maximum Signal to the following calculated value:

$$P161 = P103 + \left[\frac{(P103 - P102)}{(MRLS - ALS)} \times (MaxSV - MRLS) \right]$$

Or, in this example:

$$P161(\text{hz}) = 50(\text{hz}) + \frac{(50 - 20)(\text{hz})}{(9.1 - 5.5)(\text{VDC})} \times (10 - 9.1(\text{VDC})) = 57.5(\text{hz})$$

Do not be concerned that this setting is higher than the desired maximum – Parameter 103 will cap VFD speed below this level.

Ventilation can continue at analog signals below the CO2 concentration Action Level.

In this application example the ERV Unit is intended to run continuously. If the measured CO2 concentration is below the Action Level, the unit should run at the Minimum Design Airflow established by P102. To ensure that this happens, P215 Max Alarm Level should be set equal to P102 Minimum Hertz.

However, if it were desired to shut down the ERV Unit at all CO2 levels below the Action Level, set P215 Max Alarm Level equal to the Action Level Signal.

PARAMETERS USED IN SCALING

Parameters		Values
P101	Standard Reference Source	0 = Keypad 1 = 0–10vdc 2 = 4–20mA 3–5 = Preset #1–#3 6 = Network
P102	Minimum Frequency	Input the value in hertz
P103	Maximum Frequency	Input the value in hertz
P160	Speed at Minimum Signal	Input the value in hertz. This value may be negative but this does not call for reverse rotation.
P161	Speed at Maximum Signal	Input the value in hertz. This value may be higher than the desired maximum blower speed.
P215	Max Alarm Level	Input the value in VDC or mA, whichever you are using.

3.3.8 Examples of VFD Scaling

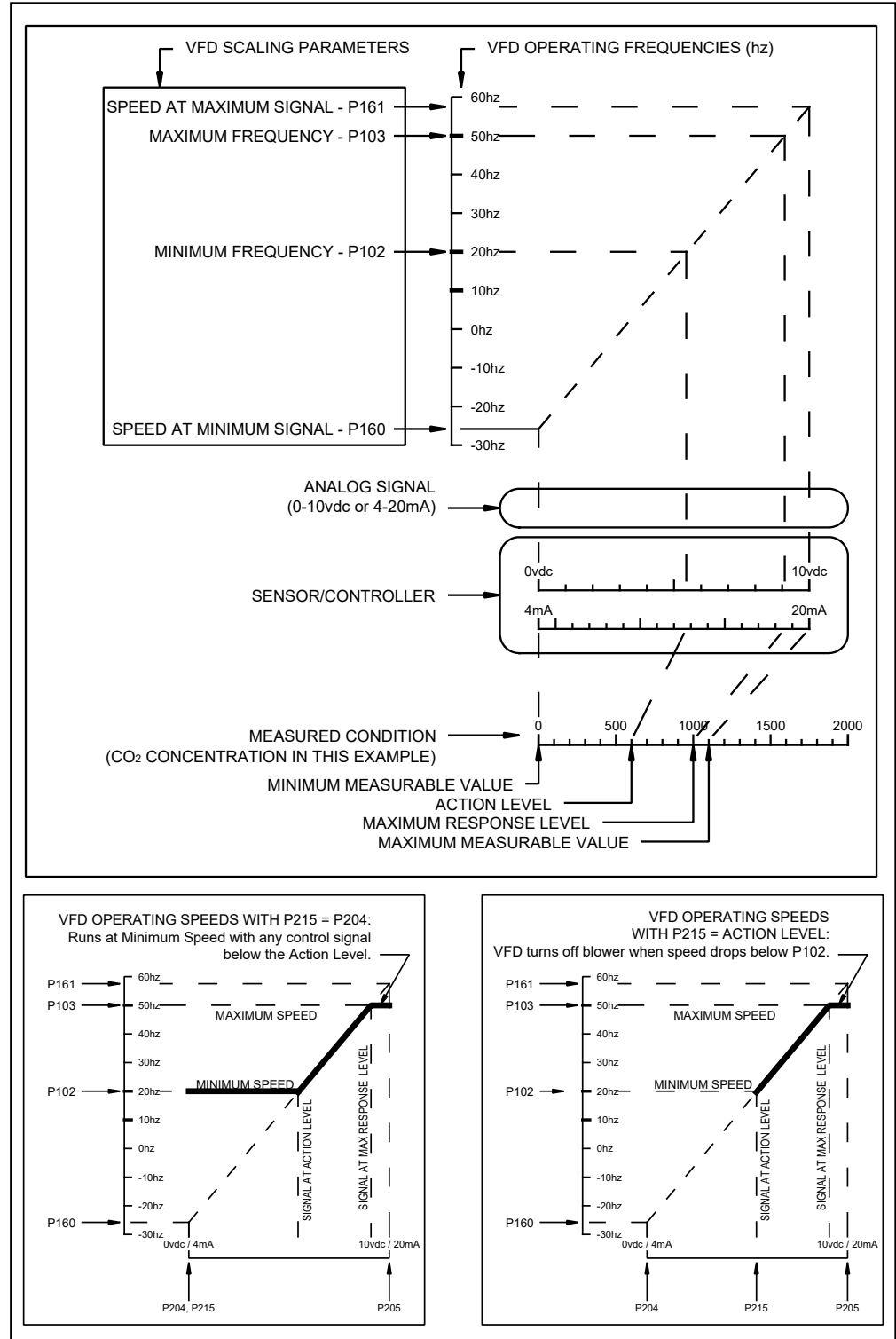

4.0 FACTORY ASSISTANCE

For questions about applications not covered in this manual, and for questions specific to the Lenze AC Tech Drives, contact Lenze AC Tech Technical Support at 800-217-9100 or (508) 278-9100. For Leeson Drives, contact Leeson Electric at (262)377-8810 or Regal Beloit Canada at (905)670-4770.

A listing of Lenze AC Tech support and service contacts can be found on the Internet at www.lenzeactech.com/drives and selecting Support and Library.

Lenze AC Tech manuals are available as PDFs at www.lenze-actech.com; select Technical Library. For Leeson Drives, visit www.leeson.com.

Lenze AC Tech offers training courses on their VFDs; navigate to www.lenze-actech.com/drives and select Training Schools.

For questions about applications covered in this manual, and for questions about how the VFDs are installed in your RenewAire ERV unit, contact RenewAire Customer Support at (800)-627-4499.



About RenewAire

For over 40 years, **RenewAire has been a pioneer in enhancing indoor air quality (IAQ)** in commercial and residential buildings of every size. This is achieved while maximizing sustainability through our fifth-generation, static-plate, enthalpic-core **Energy Recovery Ventilators (ERVs) that optimize energy efficiency**, lower capital costs via load reduction and decrease operational expenses by minimizing equipment needs, resulting in significant energy savings. Our ERVs are competitively priced, simple to install, easy to use and maintain and have a quick payback. They also enjoy the industry's best warranty with the lowest claims due to long-term reliability derived from innovative design practices, expert workmanship and **Quick Response Manufacturing (QRM)**.

As the pioneer of static-plate core technology in North America, RenewAire is the largest ERV producer in the USA. We're **committed to sustainable manufacturing** and lessening our environmental footprint, and to that end our Waunakee, WI plant is 100% powered by wind turbines. The facility is also one of the few buildings worldwide to be LEED® Gold and Green Globes certified, as well as having achieved ENERGY STAR Building status. In 2010, RenewAire joined the Soler & Palau (S&P) Ventilation Group in order to provide direct access to the latest in energy-efficient air-moving technologies. For more information, visit: renewaire.com

201 Raemisch Road | Waunakee, WI | 53597 | 800.627.4499 | RenewAire.com