

BACnet Fan Control Supplemental Installation & Operation Manual BACNETFC-W

Residential and Commercial Units

EV Premium+, SL+ 75, EV Premium, SL75, HE, LE-Series Units

INTRODUCTION

The BACnet Fan Control accessory is a wall-mounted control accessory which allows the user to turn a RenewAir Energy Recovery Unit (ERV) on and off through the keypad, through a digital input with a remote switch, or through a Building Management System (BMS) with BACnet MSTP.

HE & LE units: Can control both the supply fan and exhaust fan speeds independently according to settings made through the controller keypad or through the BMS.

EV Premium+, SL+ 75, EV Premium, & SL: Can control the fan enable signal (ON/OFF).

MOUNTING INSTRUCTIONS

⚠ CAUTION

RISK OF ELECTRIC SHOCK OR EQUIPMENT DAMAGE

Whenever electrical wiring is connected, disconnected, or changed, the power supply to the unit and its controls must be disconnected. Lock and tag the disconnect switch or circuit breaker to prevent accidental reconnection of electric power.

- Remove the captive screw that is holding the base and the front cover of the unit together.
- Lift the front cover of the unit to separate it from the base.
- Pull all wires through the holes in the base.
- Secure the base to the wall using wall anchors and screws (supplied). Make the appropriate connections.
- Mount the control module on the base and secure using the screw

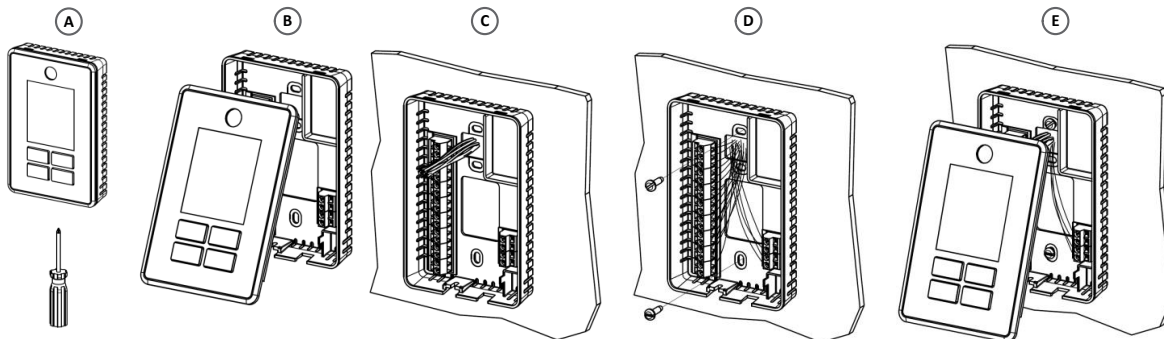

SET-UP AND WIRING INSTRUCTIONS

If the accessory is located close enough to the ERV, it can be powered from the ERV 24VAC power source. For remote connections, wire needs to be 18 gauge.

Either wire in the interlock devices, such as a smoke detector, occupancy sensor, or jumper from U1 to Common.

Set dip-switches in the correct positions, JP1 to "RUN", JP2 to "AO1", and JP3 to "NONE."

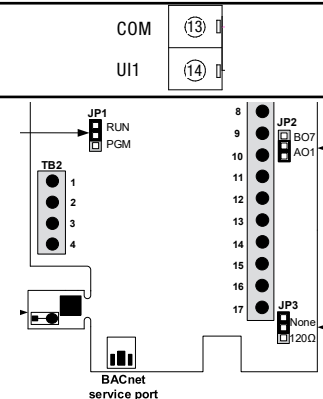

WIRING SCHEMATICS

SCHEMATICS FOR HE-SERIES AND LE-SERIES UNITS

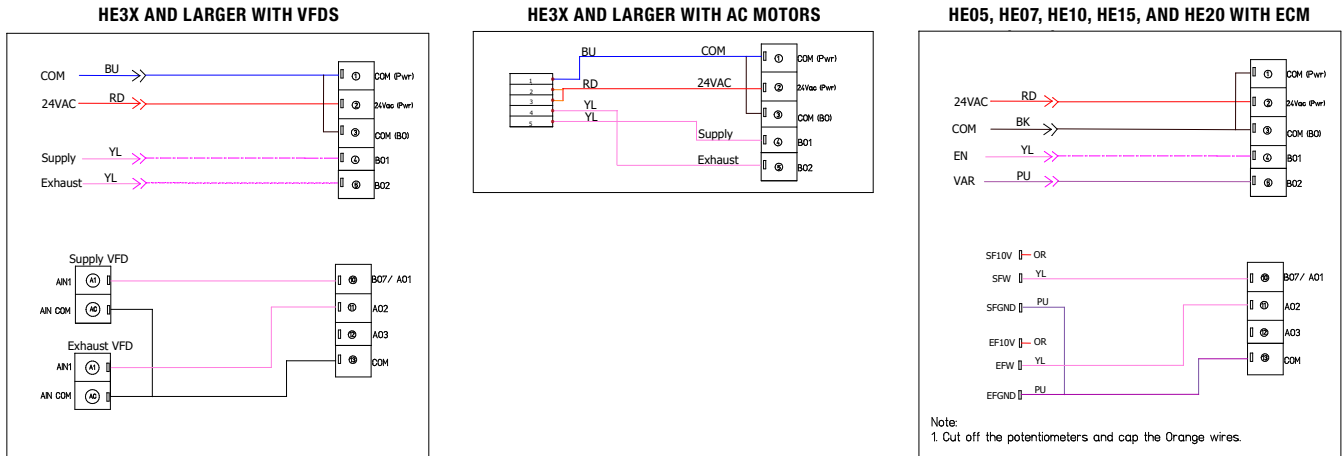

SCHEMATICS FOR SL-SERIES AND EV PREMIUM SERIES UNITS

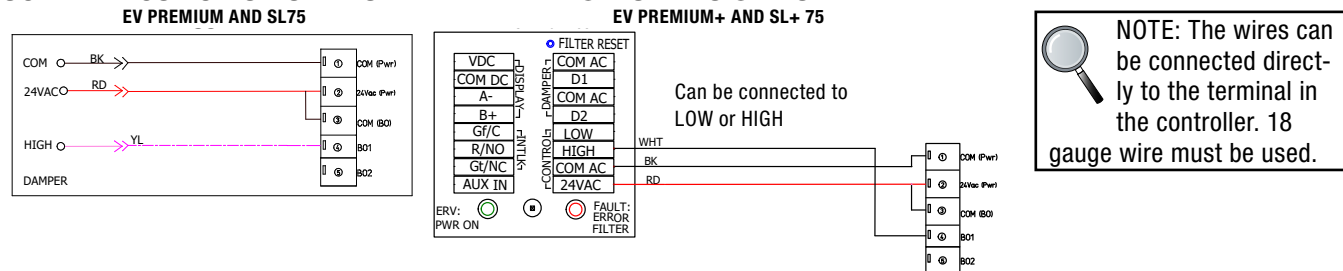







USER SETTINGS

If the unit has variable speed fans, a setting is required for each of the supply and exhaust fans to tell it how fast it should run.

To see the Fan Speed Settings, press the “FAN” button once, and then use the “UP” and “DOWN” buttons to see them. The screen will time out to the main status screen.	
Press the “FAN” button to select a value to change.	
Use the “UP” and “DOWN” buttons to change the value.	
Press the “FAN” button to confirm OR “HEAT/COOL” button to cancel and escape.	
To see the User On/Off setting, press the “HEAT/COOL” button. To change it, press it a second time.	

PROGRAM SETTINGS

In order to set the program settings, the dip-switch must be set for Program (PGM).	
Once done, you will see a wrench at the top of the screen, indicating Program Mode.	
Press the "UP" and "DOWN" buttons to get to the screens you want to change.	
Press the "FAN" button to select a value to change.	
Use the "UP" and "DOWN" buttons to change the value.	
Press the "FAN" button to confirm OR "HEAT/COOL" button to cancel and escape.	 OR 
Make sure you put the dip-switch back in the "RUN" position when done.	

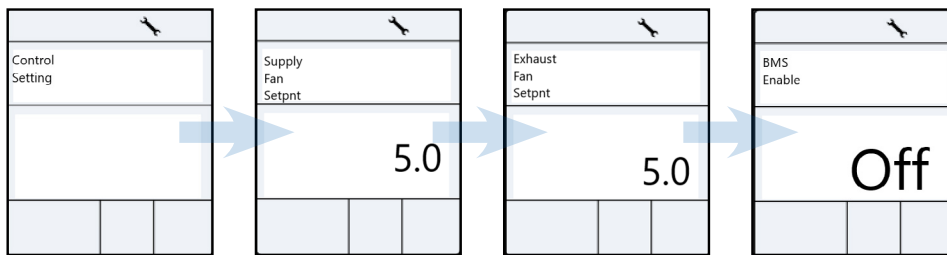

Choose BMS Enable "ON" if you want to turn the unit on and off by the BMS.

In doing so, all conditions need to be met to turn the unit on.

Supported Baud rates: 9600, 19200, 38400, 57600, 76800, 115200 bps.

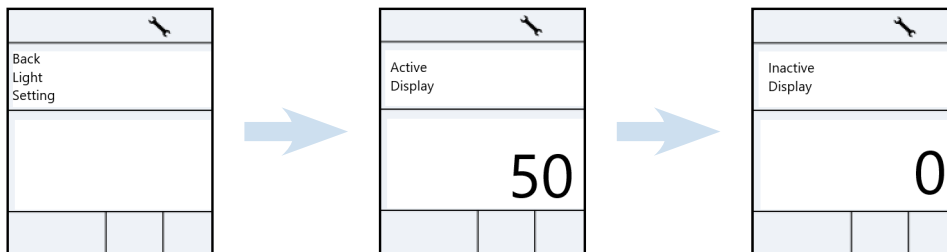
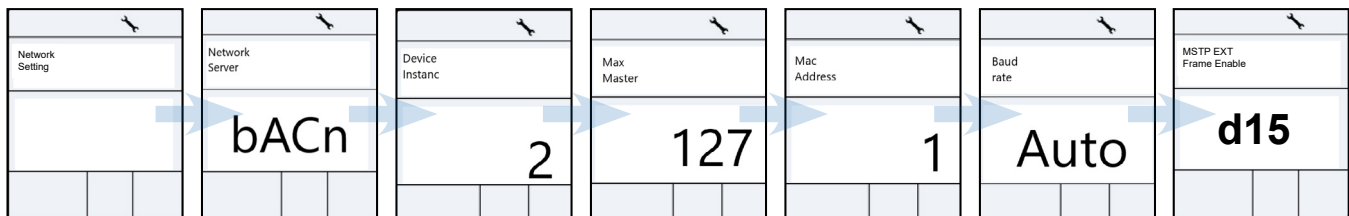

You can set the light for active and inactive display.

BACNET OBJECTS

INDEX	OBJECT NAME	OBJECT DESCRIPTION	UNIT/RANGE	DEFAULT
A0 1	Supply Fan Command	Supply Fan Analog Output. Read-only	Unit: Voltage, Range: 0.0V–10.0V, Resolution: 0.1V	N/A
A0 2	Exhaust Fan Command	Exhaust Fan Analog Output. Read-only	Unit: Voltage, Range: 0.0V–10.0V, Resolution: 0.1V	N/A
AV 1	Supply Fan Setpoint	Setpoint for Supply Fan output. Write-able from BACnet and HMI.	Unit: Voltage, Range: 0.0V–10.0V, Resolution: 0.1V	5.0V
AV 2	Exhaust Fan Setpoint	Setpoint for Exhaust Fan output. Write-able from BACnet and HMI.	Unit: Voltage, Range: 0.0V–10.0V, Resolution: 0.1V	5.0V
AV 3	Network Activity Timeout	Network Activity Timeout delay. Write-able from HMI in program mode.	Unit: Seconds, Range: 1sec–120sec, Resolution: 1Sec	60Sec
AV 7	Active Display Back-light	Active display back-light brightness. Write-able from HMI in program mode.	Unit: Percentage, Range: 0%–100%, Resolution: 5%	50%
AV 8	Inactive Display Back-light	Inactive display back-light brightness. Write-able from HMI in program mode.	Unit: Percentage, Range: 0%–100%, Resolution: 5%	50%
BI 1	Interlock	Binary Input for remote on/off signal. Read-only	0= Open, 1= Closed	N/A
BO 1	Supply Fan Enable	Supply Fan Binary Output. Read-only	0= Off, 1= On	N/A
BO 2	Exhaust Fan Enable	Exhaust Fan Binary Output. Read-only	0= Off, 1= On	N/A
BO 3	Supply Damper	Supply Damper Binary Output. Read-only	0= Off, 1= On	N/A
BO 4	Exhaust Damper	Exhaust Damper Binary Output. Read-only	0= Off, 1= On	N/A
BV 1	Enable BMS	Enable control from BMS. Write-able from BACnet	0= Off, 1= On	N/A
BV 2	BMS On/Off	BMS control mode. Write-able from BACnet	0= Off, 1= On	N/A
BV 3	User On/Off	User control mode. Write-able from BACnet and HMI.	0= Off, 1= On	N/A
BV 4	Unit Status	Unit's operation status. Read-only	0= Off, 1= On	N/A

TROUBLESHOOTING

The main screen will show you the status of the unit.



There are three indicators that show Active for turning the unit on.

They are located in the bottom row in the three boxes.

- An “A” in the left box indicates the unit is turned on by the User setting.
- An “A” in the middle box indicates the unit is turned on by the BMS if that feature is enabled.
- An “A” in the right box indicates the unit is turned on by the interlock (or jumpered).

INSTALLATION VIDEO RESOURCES



ERV Start Up with Integrated Programmable Controls



Connecting ERV to BACnet Fan Control



MSTP Integration to BACnet Fan Control