

EV SERIES Premium+ ERV

Installation, Operation and Maintenance Manual

EV Premium+ S/SH
EV Premium+ M/MH

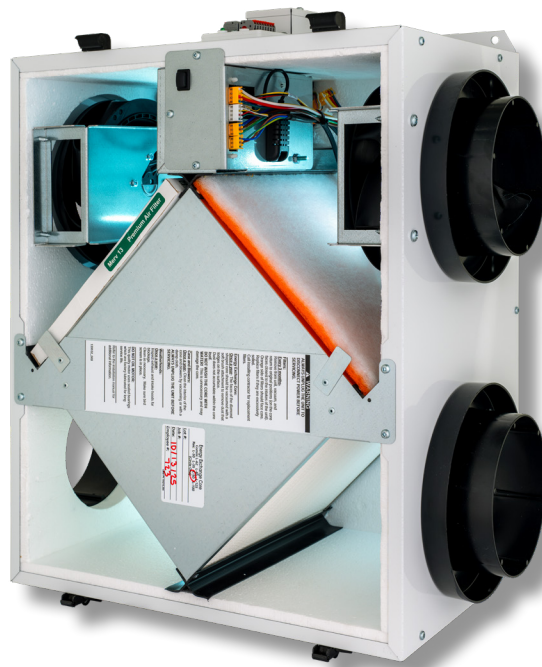

Model: EV Premium+ MH shown

⚠ CAUTION

RISK OF ELECTRIC SHOCK OR EQUIPMENT DAMAGE

Whenever electrical wiring is connected, disconnected or changed, the power supply to the Energy Recovery Ventilator (ERV) and its controls must be disconnected. Lock and tag the disconnect switch or circuit breaker to prevent accidental reconnection of electric power.

⚠ CAUTION

RISK OF INJURY FROM FALLING OBJECTS

Installation of this unit requires hoisting hardware overhead and working directly beneath heavy objects during the installation process. Observe all OSHA-approved work practices. Always wear OSHA-approved Personal Protective Equipment (PPE).

⚠ CAUTION

RISK OF CONTACT WITH HIGH SPEED MOVING PARTS

This appliance has two high speed fans that can cause injury or be damaged if objects come into contact with the impellers when they are spinning. The fans may be controlled by external controllers and switch on at any time. When working in the area of the fans, electric power to the unit must be disconnected.

IMPORTANT

This equipment is to be installed by following industry best practices and all applicable codes. Any damage to components, assemblies, subassemblies or the cabinet which is caused by improper installation practices will void the warranty.

IMPORTANT

This ERV is intended for ducted ventilation only. Ducting at least 40 inches [1 meter] in length must be installed on all four airstreams.

IMPORTANT

Only persons who have been properly trained and authorized are to access the ERV electrical box and the controller. Changes to the controller are to be made only by trained and authorized personnel.

RESIDENTIAL MODEL GUIDE

ALPHANUMERIC

E	-														X	0
---	---	--	--	--	--	--	--	--	--	--	--	--	--	--	---	---

DIGIT NUMBER

1	2	3	4	5	6	7	8	9	10	11	12	13	14	15	16	17
---	---	---	---	---	---	---	---	---	----	----	----	----	----	----	----	----

Digit 1:	Core Type
"E" = ERV	

Digit 2:	Duct Location
"E" = End/Side—4 Ducts Flexible Mounting	
"J" = End/Side—4 Ducts Flexible Mounting—Fits between Joist (24" C-C)	
"T" = Top—4 Ducts Base Mounted	

Digits 4–6:	Max CFM
"###" = Max CFM @ 0.2 ESP (Rounded)	

Digit 7:	Case Depth
"S" = > 8" & ≤ 12"	
"M" = > 12" & ≤ 18"	
"L" = > 18" & ≤ 24"	
"X" = > 24"	

Digit 8:	Cabinet Type
"F" = Foam (EPP)	
"W" = White Painted Metal	
"B" = Bare/Unpainted Metal	

Digit 10:	Power Connection
"P" = Power Cord	
"H" = Hard-Wired	

Digit 11:	Control Level/Platform
"3" = 4 Terminal Strip 24VAC-High Speed On/Off (Low On w/ Power), 1 Damper On/Off	
"5" = 16 Terminal Block 24VAC-Low/High Speed On/Off, 2 Dampers On/Off, Interlock, Remote Display, Filter/Fault/FID	

Digit 12:	Airflow Speed Capability
"4" = 2-Speed w/Constant Airflow (≤ 6 Setpoints)	
"5" = 2-Speed w/Constant Airflow (5 CFM Increments)	

Digit 13:	Additional Features
"0" = None	
"5" = OA/RA T/RH Sensors	

Digits 15–16:	Core Identification
"XB" = G5 L30	
"XC" = G5 L50	

Digit 17:	Future Use
"0" = None	

***NOTES:**

Digits 3, 9, and 14 are not used in these models.

READ AND SAVE THIS MANUAL

NOTICE

This manual has space for recording operating settings at time of unit commissioning that must be completed by the installer. See Section 4.4 of this manual.

Information that is recorded is specific to just one ERV. If additional ERVs are being documented, please make copies of these pages and identify each copy by its unit tag.

UNIT INFORMATION

Record information as shown below. In the unlikely event that factory assistance is ever required, this information will be needed.

Locate the RenewAire unit label, to be found outside of the appliance, near the terminal block. Record the model and serial numbers below.

NOTE: This information is for purposes of identifying the specific air handling appliance. Unit-specific option data can then be obtained, as needed, from the Model Number.

ERV Model: EE-130SW-P555-XB0 EE-130SW-H555-XB0
 EE-230MW-P555-XC0 EE-230MW-H555-XC0

Serial Number:

Configuration: Configuration A Configuration B

UNIT INFORMATION



Model/Modelo EE-230MW-P555-XC0 Model Name EV Premium+ M
 Serial Number **M35952723R** Part Number 166020_000

Unit Voltage 120V, 60HZ Phase/Phase1 Phase/Phase, 2.5A

MCA 15 MFS 15

Motors / Moteurs Qty 2 : 0.11 HP & 1.22 F.L.A.
 Qty 2 : 0.11 CV de chaque & 1.22 A.P.C.

Motors Thermally Protected/ Moteurs protégés thermiquement
 For permanently Connected Units: Use Copper Conductors Only
 Pour les appareils branchés en permanence: Utiliser uniquement des conducteurs en cuivre



HVI CERTIFIED RATINGS Complete ratings at: www.hvi.org

Model: EV Premium+ M
 Rated Air Flow@ 0.2 in wg (50 Pa) 233 cfm (110 L/s)
 Rated Air Flow@ 0.4 in wg (100 Pa) 218 cfm (103 L/s)

Energy Performance and Net Supply Air Flow
 203 cfm (96 L/s) at 32°F (0°C) | Power Consumed 177 W
 ASRE: 68% SRE: 62% LMT: 0.4
 51 cfm (24 L/s) at 95°F (35°C) | Power Consumed 20 W
 ATRE: 79% TRE: 77%

⚠ WARNING ⚠ AVERTISSEMENT

Danger of electric shock. Always disconnect power source before servicing.
 Do not install in a cooking area or make line-voltage electrical power connections directly between this unit and any appliance.

Danger de chocs électriques. Toujours débrancher la source d'alimentation avant la maintenance ou les réparations. Ne pas installer dans une zone de cuisson ou brancher directement la demande de courant principale de cet appareil sur n'importe quel autre appareil.

Not for Outdoor Use/ N'est pas fait pour une utilisation extérieure.



Label PN: 300895_000

UNIT LABEL (TYPICAL)

FOR THE INSTALLER	6	FOR THE HOMEOWNER	22
1.0 OVERVIEW	6	5.0 ERV INTRODUCTION AND COMPONENTS	22
1.1 INTRODUCTION.....	6	5.0.1 Terminal Block LED Indication	23
1.2 UNIT FEATURES.....	6	5.1 ERV COMPONENTS.....	23
2.0 INSTALLATION	8	5.1.1 Enthalpic Core.....	23
2.1 MOUNTING THE UNIT.....	8	5.1.2 Filters.....	23
2.2 INSTALLING DUCTWORK.....	9	5.1.3 Fans	23
3.0 ELECTRICAL HOOK-UP AND CONTROLS	12	5.1.4 Controls.....	23
3.0.1 EV Premium+ S, M.....	12	5.2 CONTROL ACCESSORIES.....	24
3.0.2 EV Premium+ SH, MH.....	12	5.2.1 Touchscreen Control+ (TC1+)	24
3.1 TERMINAL BLOCK HOOK-UP, LOW VOLTAGE	12	5.2.2 Low Voltage Countdown Timer (LVCT)	24
3.2 SPEED CONTROL OPTIONS	14	5.2.3 Low Voltage Percentage Timer (LVPT).....	24
3.3 DAMPER OPERATION	14	5.2.4 Digital Time Clock (TC7D).....	25
3.3.1 Damper installation for Continuous or Intermittent ERV Operation	14	5.2.5 CO2 Sensor, Occupancy Sensor and IAQ Sensor	25
3.4 AIR HANDLER/FURNACE INTERLOCK	15	6.0 MAINTENANCE	26
3.4.1 Condition #1: ERV OFF	15	6.1 MAINTENANCE AFTER 30 DAYS OPERATION	26
3.4.2 Condition #2: ERV ON	15	6.2 RECALIBRATION OF AIRFLOWS	26
3.5 WIRING SCHEMATICS	16	6.3 DOOR REMOVAL	26
4.0 START-UP AND COMMISSIONING	18	6.4 SERVICE PARTS	27
4.1 FAN OPERATION	18	7.0 TROUBLESHOOTING	28
4.2 SELECTING AIRFLOW SETTINGS.....	18	7.1 INDICATION OF PROBLEM.....	28
4.3 BALANCING AIRFLOWS	19	7.2 ERV HAS AIRFLOW BUT IS MAKING NOISE.....	28
4.3.1 Constant Volume.....	19	7.4 INADEQUATE OR REDUCED AIRFLOW FROM THE ERV.....	29
4.3.2 Constant Speed	19	7.7 TOUCHSCREEN CONTROL+ FAULTS.....	30
4.3.2.1 Touchscreen Control+	19	8.0 FACTORY ASSISTANCE	31
4.3.2.2 Manometer, Manual Measurements Across the Core and Filters.....	19		
4.4 CONVERSION OF PRESSURE DROP TO AIRFLOW....	21		
4.4.1 Conversion of Pressure Drop to Airflow.....	21		
4.4.2 Continuous Mode (low speed)	21		
4.4.3 Boost Mode (high speed)	21		

TABLE OF ILLUSTRATIONS

Figure 1.1.0 Airstream Illustration, Configuration A 6

Figure 1.1.1 Airstream Illustration, Configuration B 6

Figure 1.2.0 EV Premium+ Cutaway View, Configuration A shown 7

Figure 1.2.1 Controls Terminal Block 7

Figure 2.1.0 Unit Mounting Steps 8

Figure 2.1.1 Unit Mounting Steps continued 9

Figure 2.2.0 Mirrored Layouts 10

Figure 2.2.1 Separate Return Air Pick-up—Supply Air to Furnace Return Air Trunk 11

Figure 2.2.2 Separate Return Air and Supply Air 11

Figure 2.2.3 Furnace Return Air Back into Return Air 11

Figure 2.2.4 Furnace Return Air Back into Supply Air 11

Figure 3.1.0 EV Premium+ Accessories Wiring Schematic 13

Figure 3.3.0 Damper Hook-up 14

Figure 3.4.0 Air Handler/Furnace Interlock Hook-up 15

Figure 3.5.0 EV Premium+ Wiring Schematic 16

Figure 3.5.1 EV Premium+ Hard-wired Wiring Schematic 17

Figure 4.3.0 Pressure Port Locations 19

Figure 4.4.0 Pressure Drop to Airflow Conversions 21

Figure 5.0.0 EV Premium+ Airflow Pattern, Configuration A 22

Figure 5.0.1 EV Premium+ Airflow Pattern, Configuration B 22

Figure 5.1.0 ERV Components 23

Figure 5.2.0 Touchscreen Control+ (TC1+) 24

Figure 5.2.1 Low Voltage Countdown Timer (LVCT) 24

Figure 5.2.2 Low Voltage Percentage Timer (LVPT) 25

Figure 5.2.3 TC7D Control (Wall Mount) 25

Figure 5.2.4 CO2, IAQ, and Motion Occupancy Sensors 25

Figure 6.4.0 EV Premium+ Service Parts 27

 **NOTE:** Sections 1–4 of this manual contain information for the installer and sections 5–8 contain information for the homeowner or end user.

FOR THE INSTALLER

1.0 OVERVIEW

1.1 INTRODUCTION

RenewAire’s EV Premium+ units are multi-speed air-to-air energy recovery ventilators. Each unit contains a static-plate, cross-flow core that transfers both sensible and latent energy between the polluted indoor airstream being exhausted and the incoming fresh outdoor airstream being supplied to the dwelling. Airstreams do not mix, and pollutants are not transferred across partition plates. In the winter, that means that the cold, dry outside air is preheated and humidified by the outgoing warm interior air. And in the summer, the warm, humid outside air is pre-cooled and dehumidified by the outgoing air-conditioned interior air.

 **NOTE:** This unit is an energy recovery ventilator, or ERV. It is commonly referred to throughout this manual as an ERV.

 **NOTE:** Sensible energy is often referred to as “heat energy.”

 **NOTE:** Latent energy is often referred to as “moisture energy.”

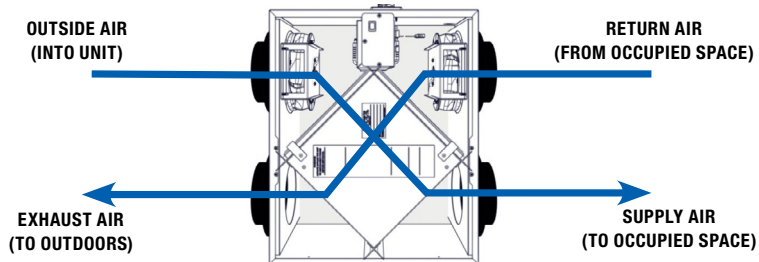

FIGURE 1.1.0 AIRSTREAM ILLUSTRATION, CONFIGURATION A

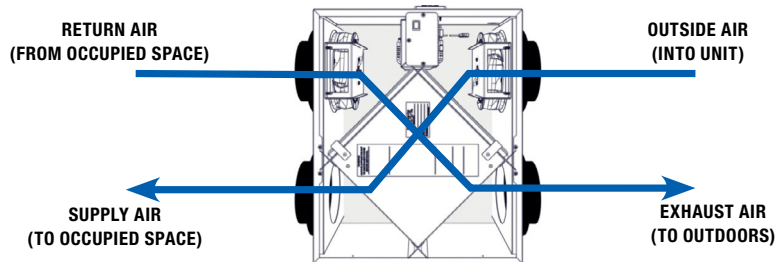

FIGURE 1.1.1 AIRSTREAM ILLUSTRATION, CONFIGURATION B

1.2 UNIT FEATURES

EV Premium+ ERVs are designed for residential applications and have multiple installation options. The units feature high efficiency, speed controllable EC motorized impellers, constant volume airflow setpoints (5 CFM increments), manual balance and airflow adjustments, and low and high speed (boost-mode) to allow independent adjustment of the outside and exhaust airstreams. EV Premium+ ERVs come factory equipped with MERV 8 filters, with MERV 13 accessories available.

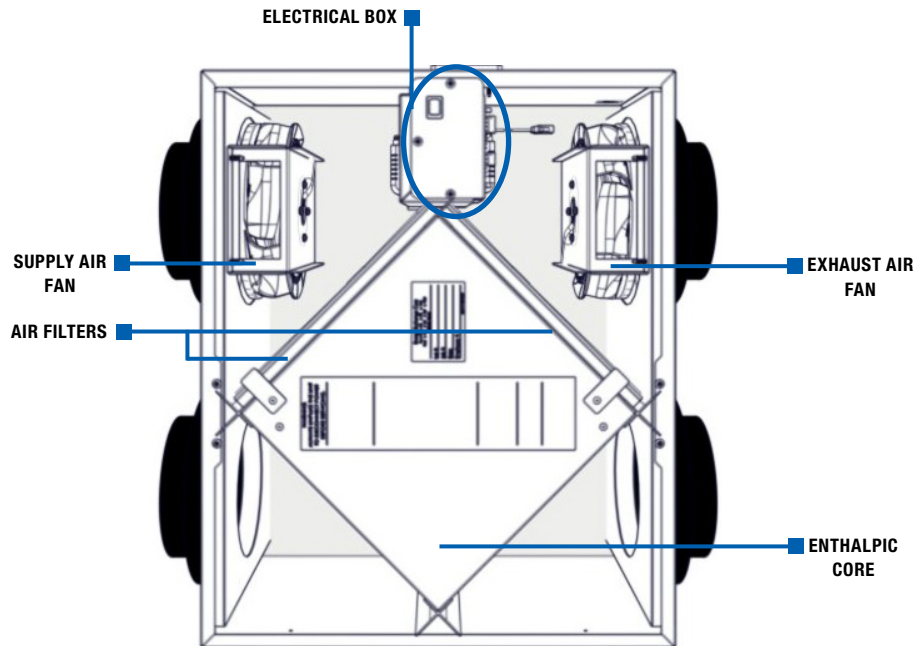
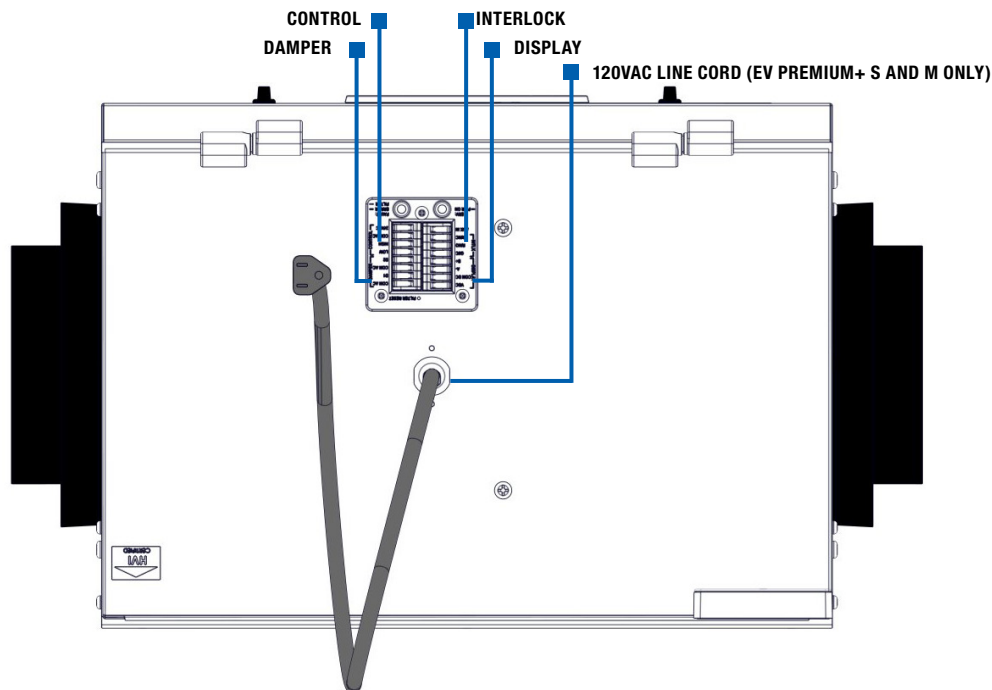

FIGURE 1.2.0 EV PREMIUM+ CUTAWAY VIEW, CONFIGURATION A SHOWN

The ERV also contains a low voltage terminal block on the end of the unit, near the line cord. Refer to section 3.0 for the various controls strategies that can be used on EV Premium+ products.



NOTE: Hardwire versions available (EV Premium+ SH and MH only)

FIGURE 1.2.1 CONTROLS TERMINAL BLOCK

NOTE: The door is equipped with slide-off hinges. For the homeowner's convenience, it is helpful to orient the unit so that the door is easily removed when unlatched.

NOTE: Do not over-tighten the screws. Compression of the gasket may result in vibration transfer.

NOTE: Wall brackets must be supported by two wall studs. If the desired location of the EV Premium+ does not permit support by two wall studs, the EV Premium+ must be mounted on a user-supplied 3/4" thick plywood panel that is anchored on two wall studs.

CAUTION
Risk of injury when lifting unit and installing it overhead.

2.0 INSTALLATION

2.1 MOUNTING THE UNIT

EV Premium+ ERVs may be installed in any position providing sufficient clearance for controls and door access. The preferred position is horizontal so that the hinged access door can swing down to allow for easiest filter changes and cleaning of the enthalpic core.

To mount the unit to a concrete foundation or stud wall, mount hanging bracket to the wall with appropriate concrete anchors. Use pre-cut foam tape from small parts bag. Remove backing and apply two pieces of foam tape equally spaced along the unit's mounting flange to be held by the hanging bracket. Apply the other two pieces of foam over two holes that will be used for fastening, on the other flange. The tape should be applied in a "U" shape to cushion both the front and back of the integral flanges.

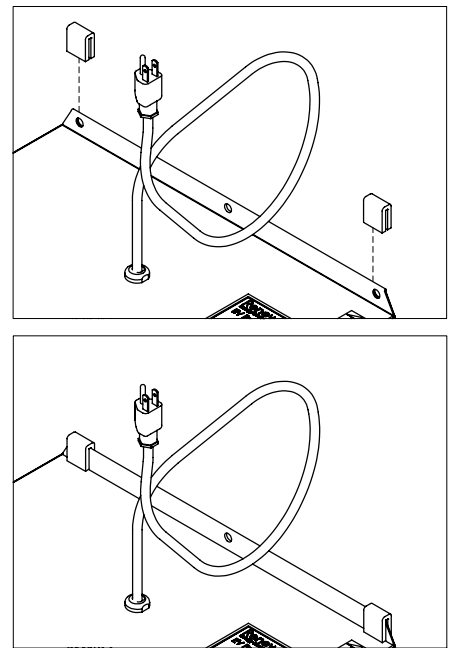
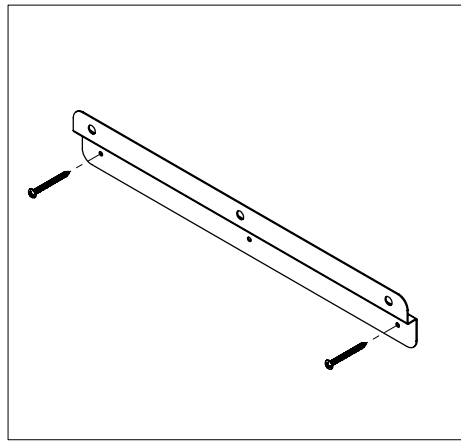

FIGURE 2.1.0 UNIT MOUNTING STEPS

Lift unit and slide unit flange into the hanging bracket. Using metal flat washers, fasten flange opposite hanging bracket to structure. Safety screws should similarly be installed passing through the hanging bracket and flange. Make sure the screws, which must be supplied by the installer, are properly selected for the loads and substrate involved, 2" x #10 pan head screws are recommended.

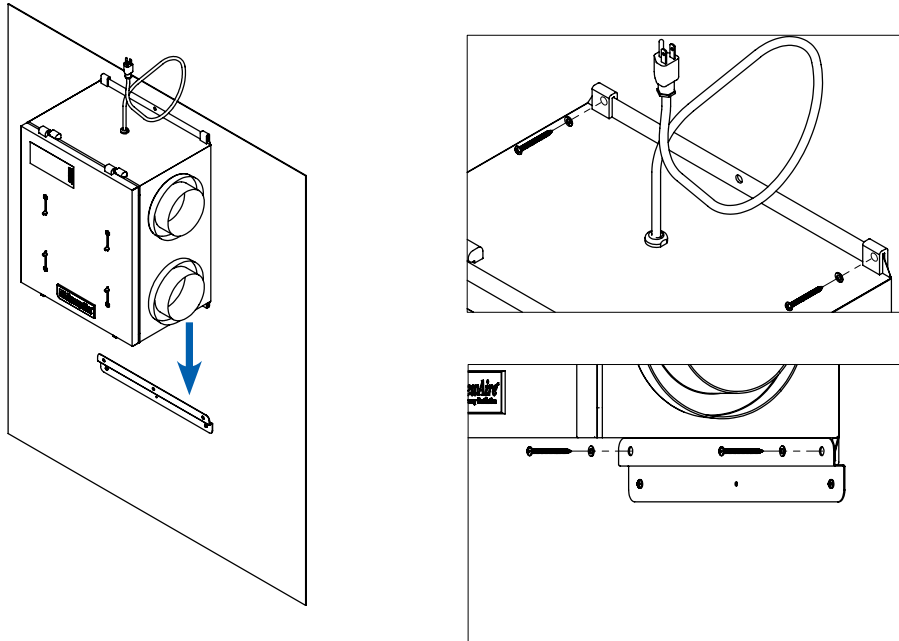

FIGURE 2.1.1 UNIT MOUNTING STEPS CONTINUED

The unit may also be screwed directly to joists or trusses using the hanging bracket and integral flange. Mount as described for mounting to concrete foundation wall.

When installing the unit be sure to allow sufficient space to open the door latches and for the door to be able to swing open at least 90°. Also ensure there is space to access the terminal block at the end of the unit.

2.2 INSTALLING DUCTWORK

IMPORTANT

It is important to understand and use the equipment airstream terminology as it is used in this manual. The airstreams are defined as:

- Outside Air (OA): Air taken from the external atmosphere and, therefore, not previously circulated through the system.
- Supply Air (SA): Air that is downstream of the enthalpic core and is either supplied to the occupied space or to an additional conditioner.
- Conditioned Air (CA): Air that is supplied to an occupied space.
- Return Air (RA): Air that is returned to a heating or cooling appliance from a conditioned space.
- Exhaust Air (EA): Air that is removed from a heating or cooling appliance and discharged.

EV Premium+ units are supplied with a set of 4 duct connectors that must be field-installed. The EV Premium+ S/SH and M/MH connectors can be used with 6" or 8" round ducts. It is preferable to keep duct runs short and straight to maximize performance.

For all installations, SMACNA guidelines for duct installation should be followed. The most commonly used ducting is 6" diameter flexible due to ease of installation, sound attenuation, and cost, however, rigid ducting is preferred because there is less resistance to airflow, resulting in less power consumption to deliver the same amount of air.

A total of four duct runs will generally be used:

- Outdoor Air Intake (OA): This duct will provide clean outdoor air to the unit, and is normally capped by an air inlet cap mounted on the exterior side wall of a residence and equipped with a bird screen.





NOTE: Ducts inside a building that are connected to the outside must be insulated with a sealed vapor barrier on both the inside and the outside of the insulation.

Insulation must have an R-value of at least R-6, but R-8 is recommended.

Wall intakes must be located at least 10' from any appliance vent or any vent opening from a plumbing drainage system and 10' from any exhaust fan discharge outlet unless that outlet is 3' or more above the intake location (IRC 2006, Section M1602.2). If a combined exhaust/intake termination is used (with non-kitchen exhaust only) then no minimum separation is required when the exhaust air concentration within the intake airflow does not exceed 10% as established by the manufacturer. (ASHRAE 62.2-2019, Section 6.68).

- Fresh Supply Air (SA): This duct will deliver fresh, conditioned air from the ERV to a desired location in the residence. This duct run may end in a floor or wall grate with an area of at least 28 square inches. Alternatively, the supply air duct may be connected directly into the return air duct or the supply air duct for the main heating and cooling system. When connecting to the main return air duct, it must be at least 3' from the return plenum to minimize suction from the furnace blower.
- Indoor Return Air (RA): This duct will collect indoor air from return grilles and run it through the ERV for energy recovery before being exhausted to the outdoors.
- Outdoor Exhaust Air (EA): This duct exhausts stale indoor air to the outdoors after being run through the energy recovery core. This duct will normally end at an exhaust cap located on an exterior wall of a residence.
- Airstreams may be swapped during installation. This is an acceptable installation that does not effect unit performance or warranty, see Figure 2.2.0. Mirrored units may require unit to be rotated 180 degrees during installation and airflow configuration changed during setup, see Figure 2.2.0. If paired with TC1+, airstream configuration can be selected digitally to match configuration A or B, refer to the sticker on the ERV. See Figure 1.1.0 and 1.1.1 for more information.

 NOTE: The installer should note the airstream configuration on page 3 of this manual.

 NOTE: Mirroring is not limited to Figure 2.2.0 and is applicable to Figures 2.2.1–2.2.4.

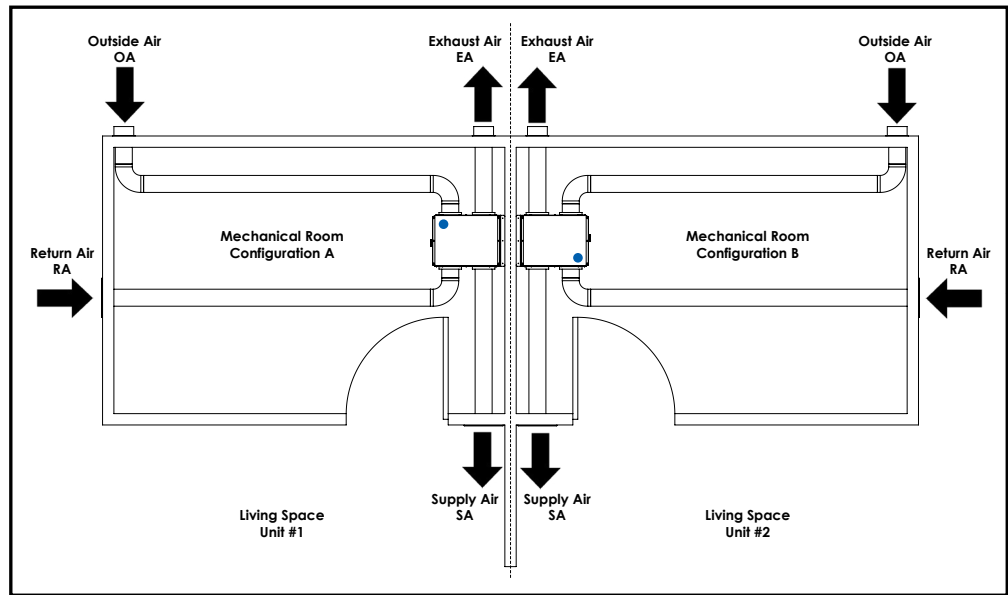

FIGURE 2.2.0 MIRRORED LAYOUTS

Figures 2.2.1-2.2.4 show a few common installation methods.

If the unit is located in a conditioned space, only the OA and EA ducts need to be insulated. For unconditioned space installations such as an attic or crawl space all four ducts must be insulated and have the application evaluated by a HVAC design professional or RenewAire.

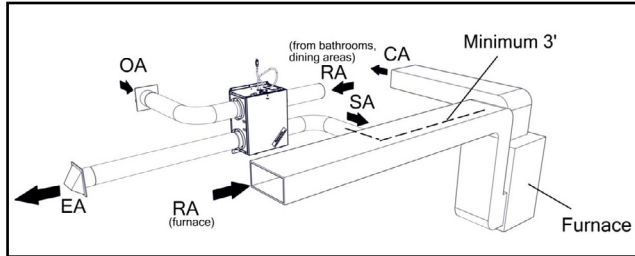

FIGURE 2.2.1 SEPARATE RETURN AIR PICK-UP—SUPPLY AIR TO FURNACE RETURN AIR TRUNK

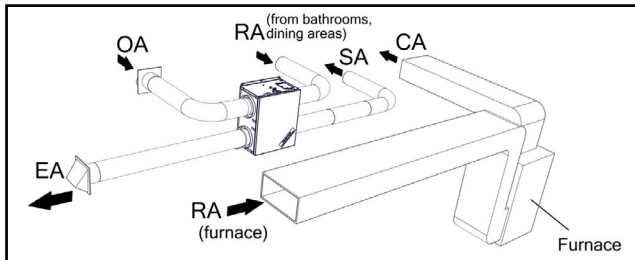

FIGURE 2.2.2 SEPARATE RETURN AIR AND SUPPLY AIR

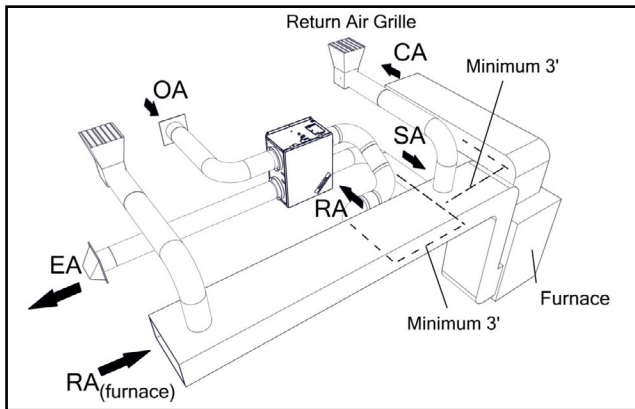

FIGURE 2.2.3 FURNACE RETURN AIR BACK INTO RETURN AIR

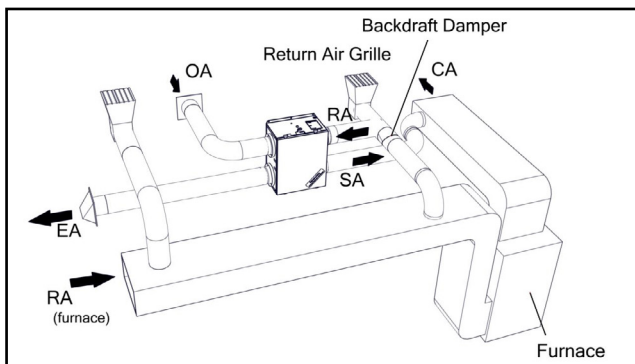

FIGURE 2.2.4 FURNACE RETURN AIR BACK INTO SUPPLY AIR

NOTE: For units with mirrored airstreams, Figures 2.2.1–2.2.4 are mirrored.

NOTE: ERV blower may be operated separate from furnace blower.

NOTE: ERV blower may be operated independently from furnace blower. Use caution to introduce SA at low velocity and where good mixing will occur to minimize discomfort from drafts

NOTE: For the setup in Figure 2.2.3, the furnace blower must be operated any time the ERV is operated. Use furnace fan “on” continuous low speed or connect furnace to the terminal block terminal Gf/C for furnace interlock to cycle furnace fan on.

NOTE: ERV blower may be operated separate from furnace blower.

3.0 ELECTRICAL HOOK-UP AND CONTROLS

3.0.1 EV Premium+ S, M

Power requirements for EV Premium+ S, M: 120VAC, 3.0 amps

The EV Premium+ S and M have an integral 34" long power supply cord. The installer must provide a standard, grounded 120VAC outlet in the proximity of the ERV. Check all local codes.

3.0.2 EV Premium+ SH, MH

Power requirements for EV Premium+ SH, MH: 120VAC, 3.0 amps

The EV Premium+ SH and MH are to be hard-wired by the installer. Check all local codes before wiring. A disconnect switch on the AC supply line may be required.

3.1 TERMINAL BLOCK HOOK-UP, LOW VOLTAGE

Figure 3.1.0 is a common wiring schematic for a hook-up that includes furnace interlock, but the EV Premium+ series is not limited to this configuration. The accessories wired include a Touchscreen Control+ (TC1+), two Motorized Dampers, and two Low Voltage Countdown Timers (LVCT) wired in parallel.

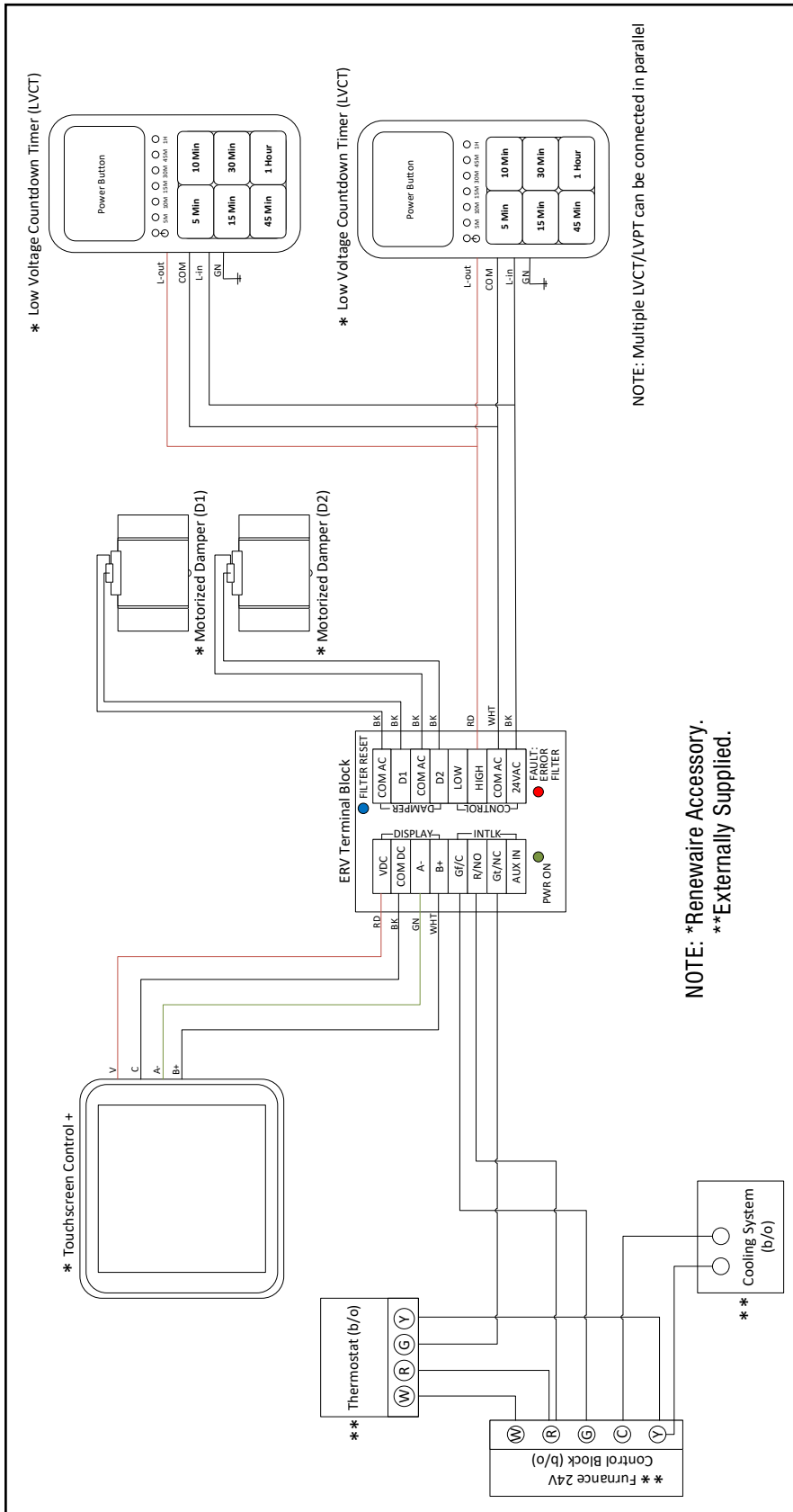
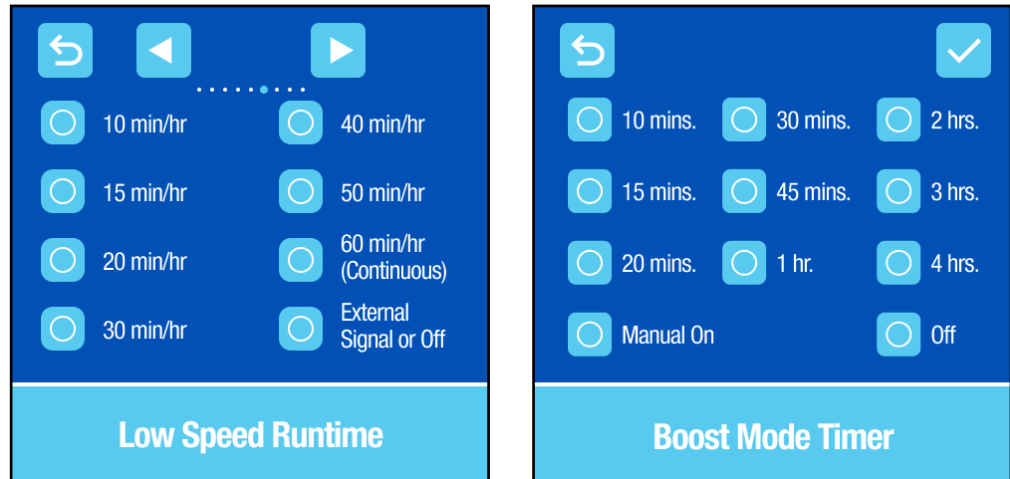

FIGURE 3.1.0 EV PREMIUM+ ACCESSORIES WIRING SCHEMATIC

3.2 SPEED CONTROL OPTIONS

When plugged in, from the factory, the unit will be set to ventilate in the supply and exhaust airstreams and the runtime will be set to External Signal or Off, the fans will not rotate. Refer to the submittal for factory low and high speed airflow setpoints if needed. To change the low or high speed setpoint the TC1+ is required for setup but operation can continue without the TC1+.

When paired with the TC1+ the EV Premium+ series can operate in single speed continuous, single speed intermittent, low speed continuous/high speed switched, or low speed intermittent/high speed switched mode. These can be configured with the desired constant volume or constant speed values in the TC1+ unit setup procedure.



3.3 DAMPER OPERATION

When the ERV is connected to a ducted return of the HVAC system, outdoor air may be pulled through the ERV via the HVAC fan. This can be prevented by installation of a damper installed at the supply air outlet of the ERV. RenewAire's MD-Series 24-volt dampers can be wired to an EV Premium+ unit for this purpose. For more detailed information on installation, please refer to the *MD-Series Damper Manual*.

3.3.1 Damper installation for Continuous or Intermittent ERV Operation

The ERV can be wired to operate with one or two MD series dampers. Connect the damper lead wires to D1 and/or D2 (24VAC) and COM AC terminal(s) on the terminal block, not polarity sensitive. The damper(s) will open when the ERV fan is commanded to run and will close when the fan is commanded to off or when power is lost, dampers are configured as normally closed.

REQUIRED: The damper connected to D1 must correspond to OA/SA and D2 must correspond to RA/EA in the factory default airstream configuration (Configuration A). The TC1+ will handle airflow swapping via software. Do not swap the D1 and D2 physical connections or the dampers will be commanded to open with the wrong airstream.

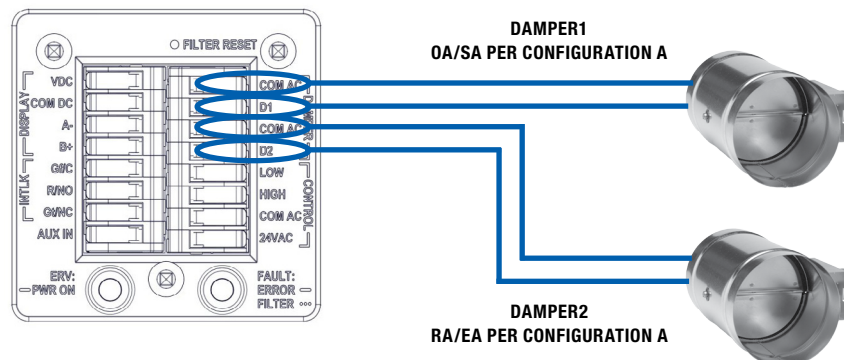

FIGURE 3.3.0 DAMPER HOOK-UP

3.4 AIR HANDLER/FURNACE INTERLOCK

If your installation requires the air handler/furnace blower to operate anytime the ERV is signaled to run, refer to Figure 3.4.0 for wire hook-ups.

3.4.1 Condition #1: ERV OFF

Thermostat signal passes through the ERV. The ERV relay between Gt (thermostat) and Gf (air handler/furnace) is normally closed, sending the 24V back to the air handler/furnace G terminal to operate the air handler/furnace blower.

3.4.2 Condition #2: ERV ON

Thermostat signal overridden by the ERV. The ERV relay between R and Gf will close, while simultaneously opening the relay between Gt and Gf, sending the 24V back to the air handler/furnace G terminal to operate the furnace blower.

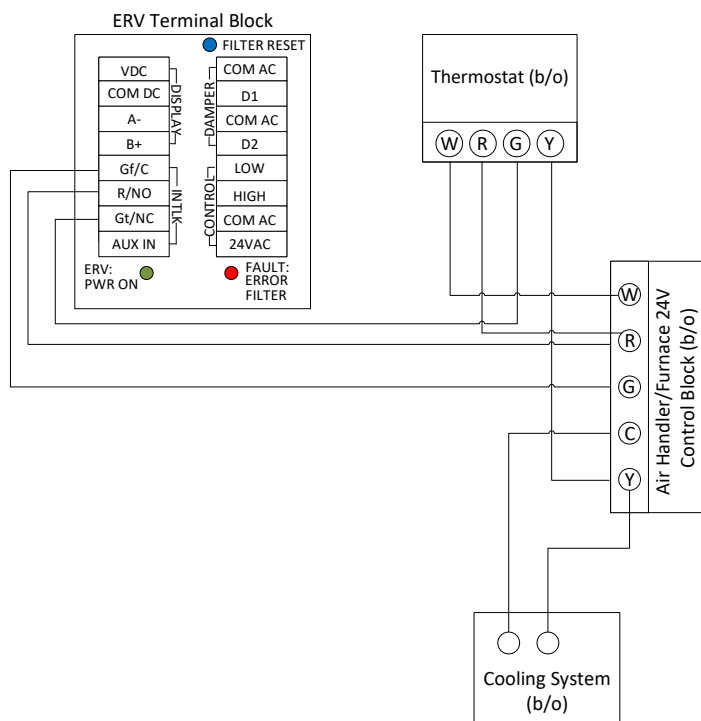

FIGURE 3.4.0 AIR HANDLER/FURNACE INTERLOCK HOOK-UP

3.5 WIRING SCHEMATICS

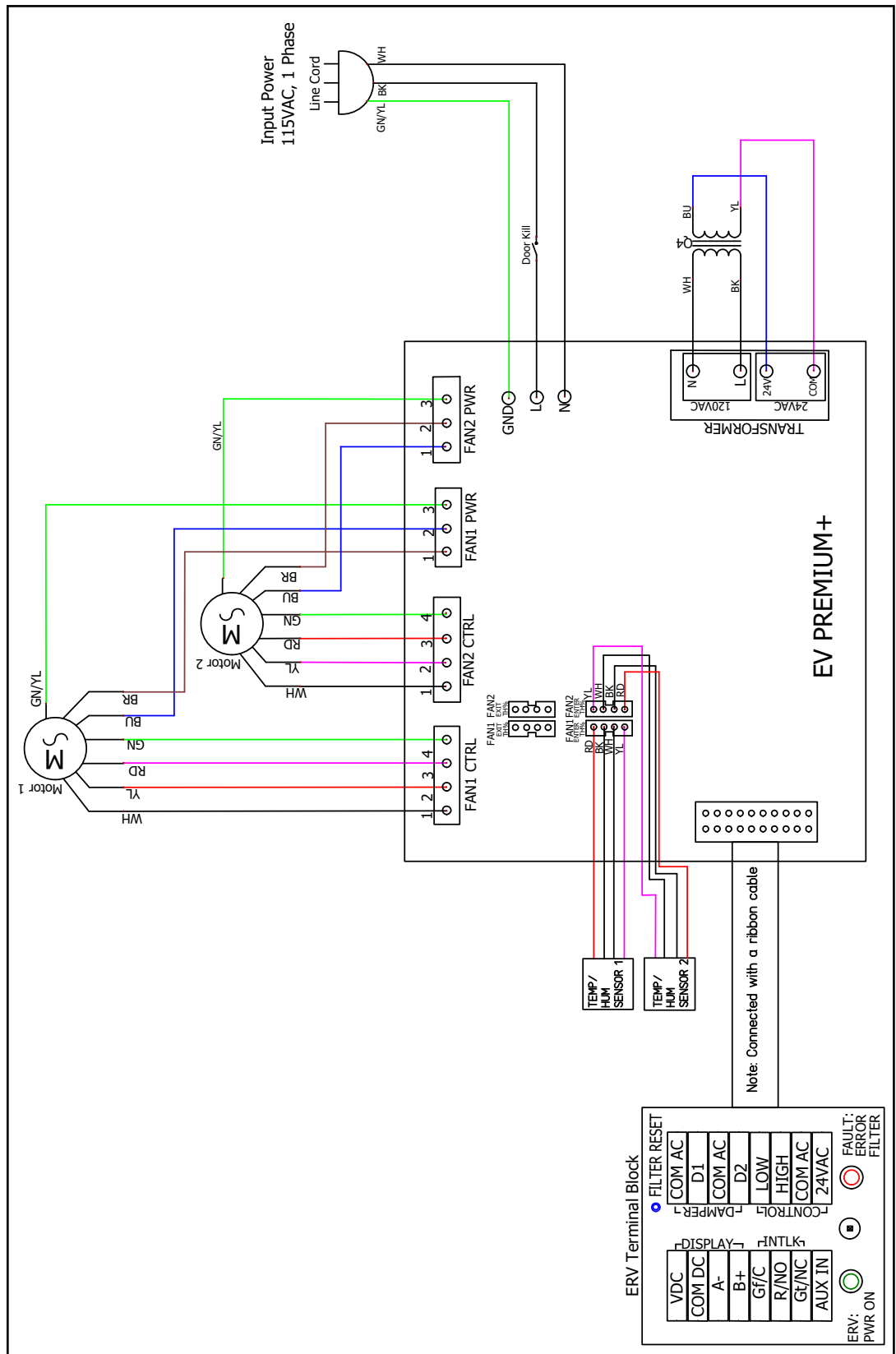

FIGURE 3.5.0 EV PREMIUM+ WIRING SCHEMATIC

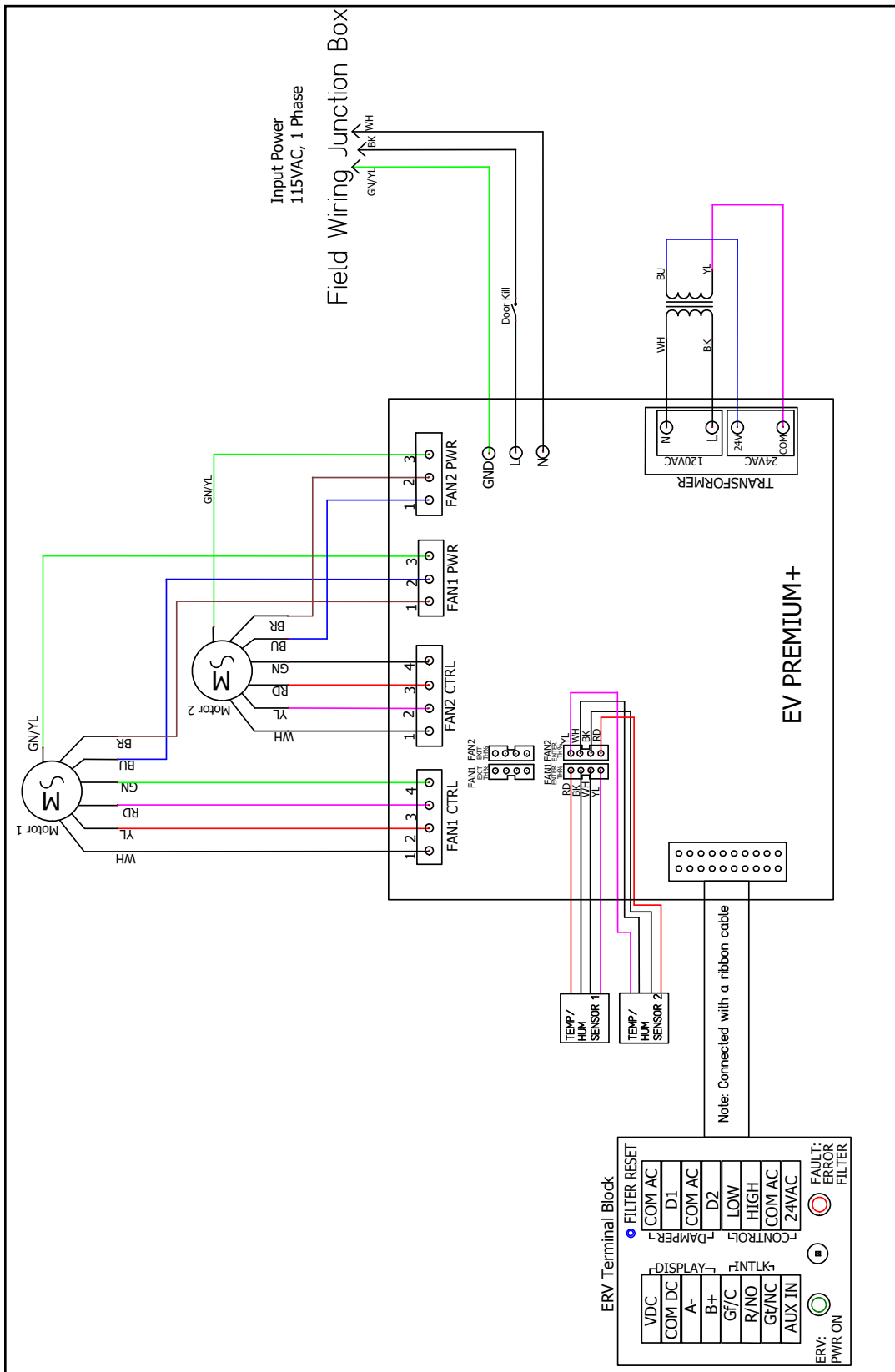

FIGURE 3.5.1 EV PREMIUM+ HARD-WIRED WIRING SCHEMATIC

4.0 START-UP AND COMMISSIONING

4.1 FAN OPERATION

EV Premium+ units have three operating modes: Continuous, Boost, and Intermittent. Continuous mode should be set to provide the minimum ventilation requirement. Boost mode can be used to supply and exhaust a greater volume of air. Intermittent mode can be used if ventilation is not required continuously.

The three operating modes are selectable and controlled independently so that different controlling methods can be used to switch back and forth.

The unit comes with a preset low and high speed setpoint from the factory. To change the low or high speed setpoint the TC1+ is required for setup but operation can continue without the TC1+. Follow the unit setup procedure in the TC1+ Setup Guide for complete instructions to commission the unit.

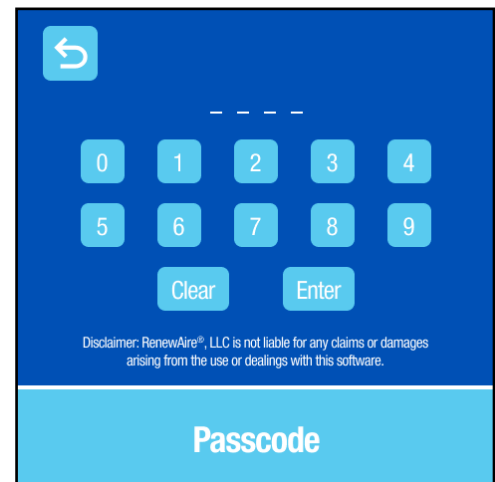
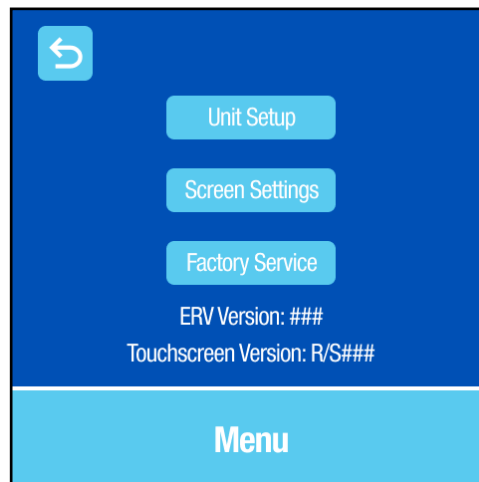
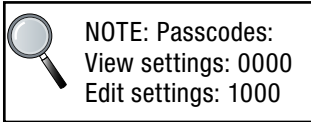

4.2 SELECTING AIRFLOW SETTINGS

For assistance in determining correct airflow settings, go to <https://renewaire.com/residential-ervs/> and scroll down to the Select a RenewAire ERV for Your Home section to use the CFM calculator. This site will provide a basic low-speed (Continuous) air volume for a residence based on factors such as square footage and the number of bedrooms that are to be entered by the user. The resulting airflow volume is to be used as a guide and modified as desired.

The need for boost mode varies by situation. For example, boost mode could be tied to bathroom and shower usage. Alternatively, boost mode might be set for specific times of the day when more people will be in the space being ventilated. In all cases, an HVAC professional should be consulted to determine how to best set the airflow volumes to provide maximum benefit to the inhabitants.

The EV Premium+ series airflow can be selected to operate at desired Constant Volume CFM setpoints, within a specified range, or Constant Speed setpoints, percent of max fan speed.

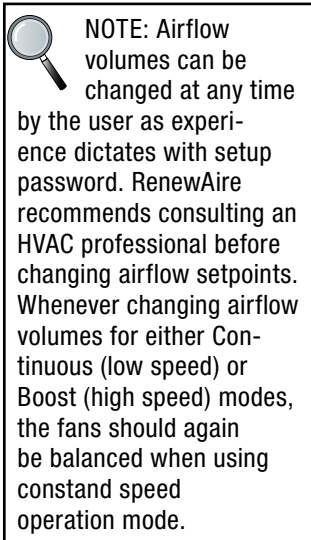

4.3 BALANCING AIRFLOWS

EV Premium+ ERVs provide the ability to deliver and exhaust completely balanced airflows, or to modify them as desired. While balanced airflow is preferred, many homeowners will prefer to have a slight imbalance, providing a slight excess of Outdoor Air to reduce air infiltration into a home. Some homes may require an imbalance because a furnace or water heater is not direct-vented. Again, an HVAC professional will be able to advise balance settings that will best address the circumstances in each home. EV Premium+ ERVs require the TC1+, sold separately as an accessory, to change airflow values for setup. Refer to the unit submittal document for specifics on airflow and external static pressure operating ranges.

Balancing airflows is done by setting the OA airflow volume and then adjusting the RA airflow volume to eject the same or somewhat less air to the outdoors.

4.3.1 Constant Volume

The Constant Volume control strategy is the easiest way to balance airflows. Set the Constant Volume setpoints on the TC1+ and the ERV controller will autobalance the fans to the target CFM setpoint.

4.3.2 Constant Speed

If using Constant Speed (% of max speed), there are two ways to balance the airflows.

4.3.2.1 Touchscreen Control+

Set the supply and exhaust values to be the same and complete the unit setup. The live airflow values will be displayed on the home screen, allow the airflows to stabilize. If the airstreams are imbalanced, adjust the values in the unit setup to match the desired airflow(s). Do this for both the low and high speed setpoints.

4.3.2.2 Manometer, Manual Measurements Across the Core and Filters

Equipment required for testing airflows:

- A magnehelic gauge (or manometer) or other device capable of measuring 0–1.0 inches water gauge of differential pressure.
- 2 pieces of natural rubber latex tubing, 1/8" I.D., 1/16" wall thickness works best.

Manometers are devices that are readily available from online retailers; accuracy within the range of 0–1.0 in. w.g. is the critical requirement. Water manometers generally have graduations of 0.1" that are difficult to accurately determine. For all manometers, there are two plastic tubes that connect at the manometer and then the other ends go to pressure ports on the ERV.

Individual differential static pressures (DP) are measured across the core and filters, using the installed pressure ports located on the removable door.

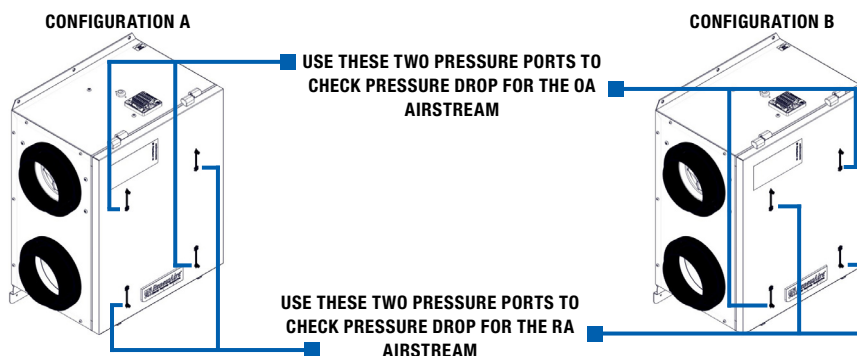

FIGURE 4.3.0 PRESSURE PORT LOCATIONS

- ♦ Verify the unit has clean filters in place.
- ♦ Open the pressure port caps for the OA airstream and then insert the tubing into the openings about 1".
- ♦ Use the TC1+ or manually jumper the unit to operate the fans in low or high speed. To manually force the fans to run install a jumper between the 24VAC and LOW or 24VAC and HIGH speed terminals to power the fans.
- ♦ Take a differential pressure reading for the OA airstream by installing the “high” pressure side (+) of the measuring device to the OA port and the “low” pressure side (-) to the SA port. Compare the pressure drop to the chart in section 4.4.1 to obtain the CFM. Adjust the fan speed to obtain the desired CFM. Enter the CFM information in the box in section 4.4.
- ♦ Take a differential pressure reading for the RA airstream by installing the “high” pressure side (+) of the measuring device to the RA port and the “low” pressure side (-) to the EA port. Compare the pressure drop to the chart in section 4.4.1 to obtain the CFM. Adjust the fan speed to obtain the desired CFM. Enter the CFM information in the box in section 4.4.
- ♦ Repeat the process for low and high speeds.

4.4 CONVERSION OF PRESSURE DROP TO AIRFLOW

4.4.1 Conversion of Pressure Drop to Airflow

See the tables below. TC1+ will also display airflows.

(Units equipped with clean MERV 8 filters.)

To determine the airflow in CFM, obtain the manometer readings shown above and calculate the differences between them. Then apply the following formula to convert the readings to CFM:

EV Premium+ S/SH: [Airflow in CFM] = 183 x [Pressure Drop in inches w.g.]

EV Premium+ M/MH: [Airflow in CFM] = 283 x [Pressure Drop in inches w.g.]

EXAMPLE: 1 In. w.g. of pressure drop corresponds to 283 CFM, 0.5 In. w.g. corresponds to 141.5 CFM, and so on for the EV Premium+ M.

(Units equipped with a MERV 13 filter in the OA airstream. Formulas below are for OA airstream only.)

EV Premium+ S/SH: [Airflow in CFM] = 154 x [Core Pressure Drop in inches w.g.]

EV Premium+ M/MH: [Airflow in CFM] = 235 x [Core Pressure Drop in inches w.g.]

EXAMPLE: 1 In. w.g. of pressure drop across the core corresponds to 235 CFM, 0.5 In. w.g. corresponds to 117.5 CFM, and so on for the EV Premium+ M.

EV PREMIUM+ S/SH			EV PREMIUM+ M/MH		
Pressure Drop (In. W.G.)	Airflow with MERV 8 Filters (CFM)	Airflow with MERV 13 Filters (CFM)	Pressure Drop (In. W.G.)	Airflow with MERV 8 Filters (CFM)	Airflow with MERV 13 Filters (CFM)
0.1	18	15	0.1	28	24
0.2	37	31	0.2	57	47
0.3	55	46	0.3	85	71
0.4	73	62	0.4	113	94
0.5	92	77	0.5	142	118
0.6	110	92	0.6	170	141
0.7	128	108	0.7	198	165

FIGURE 4.4.0 PRESSURE DROP TO AIRFLOW CONVERSIONS

4.4.2 Continuous Mode (low speed)

Outdoor Airflow: CFM

Return Airflow: CFM

4.4.3 Boost Mode (high speed)

Outdoor Airflow: CFM

Return Airflow: CFM

FOR THE HOMEOWNER

5.0 ERV INTRODUCTION AND COMPONENTS

The purpose of your EV Premium+ ERV is to bring fresh air into your home, and exhaust stale room air improving your indoor air quality. While bringing fresh air into your home, the ERV uses the stale exhaust air to transfer heat and moisture without mixing, reducing the demand on the rest of your HVAC system.

NOTE: Airstreams may be configured in configuration A or B depending on the installation. The installer should note what airstream configuration is used by checking the coordinating box on the configuration label on the door. This can also be found in the Touch-screen Control+ menus.

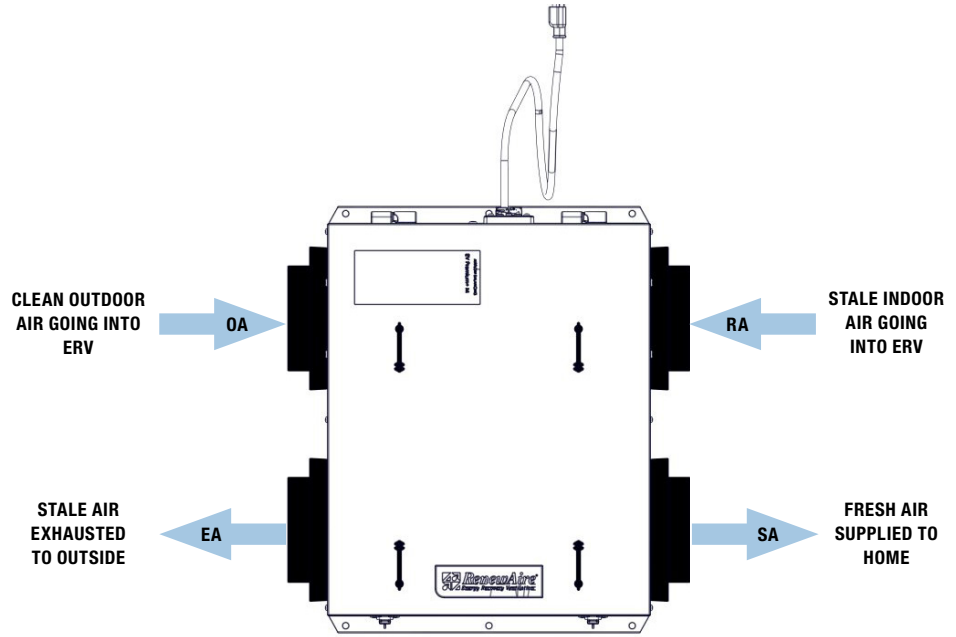

FIGURE 5.0.0 EV PREMIUM+ AIRFLOW PATTERN, CONFIGURATION A

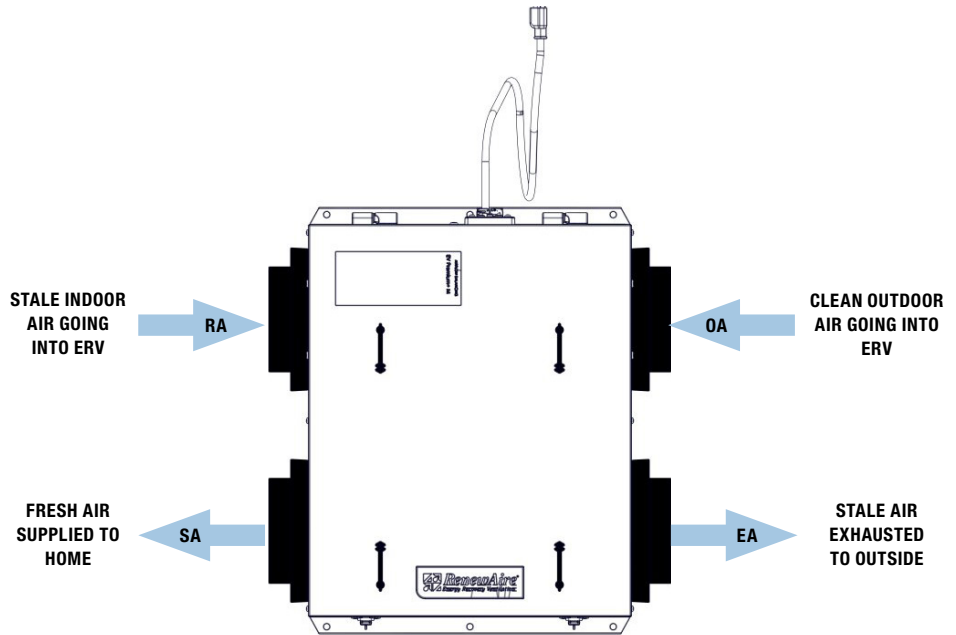

FIGURE 5.0.1 EV PREMIUM+ AIRFLOW PATTERN, CONFIGURATION B

5.0.1 Terminal Block LED Indication

LED Indication on ERV Terminal Block	Meaning
Solid Green	ERV on, 120VAC present at control board
Solid Red	Motor RPM or airflow low SA/EA
Blinking Red	Replace filter, fan run time exceeded 90 days since last reset

5.1 ERV COMPONENTS

The main components in your EV Premium+ ERV are the static plate core, two filters, two motorized fans and the controls system.

5.1.1 Enthalpic Core

As mentioned above, each EV Premium+ ERV unit contains a static-plate, cross-flow core that transfers both sensible and latent energy between the polluted indoor airstream being exhausted and the incoming fresh outdoor airstream being supplied to the dwelling. Airstreams do not mix, and pollutants are not transferred across partition plates.

5.1.2 Filters

Each unit is equipped at the factory with mesh-type anti-microbial MERV 8 filters on both the OA and RA sides of the core. If desired, the mesh-type OA filter can be replaced with an optional MERV 13 pleated paper filter accessory, which will ship loose.

5.1.3 Fans

EV Premium+ units have two advanced, high efficiency electronically commutated (EC) 120VAC variable speed fans. One fan is used for intake air (Outdoor Air/Supply Air) and the other fan is for the exhaust airstream (Return Air/Exhaust Air). The speed of each fan is controlled independently by a 0–10VDC signal from the controller.

5.1.4 Controls

The controller provides the signal to the EC motors based on the setpoint for constant volume or percent of max speed set on the TC1+. Incoming line voltage powers both fans and also a step-down Class II transformer which provides 24VAC to the externally-mounted low-voltage terminal block.

Each unit has a 16 position leg spring terminal block mounted on the end of the unit. The terminal block has multiple 24VAC power supply terminals. The unit control board provides up to 20VA (approximately 0.8A) which can be used to power the various optional control accessories.

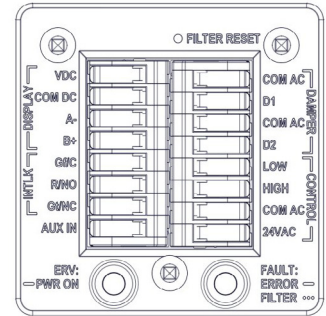

NOTE: After filter is replaced reset filter replacement timing by pressing a paperclip end or similar sized object into the filter reset opening in the terminal block.

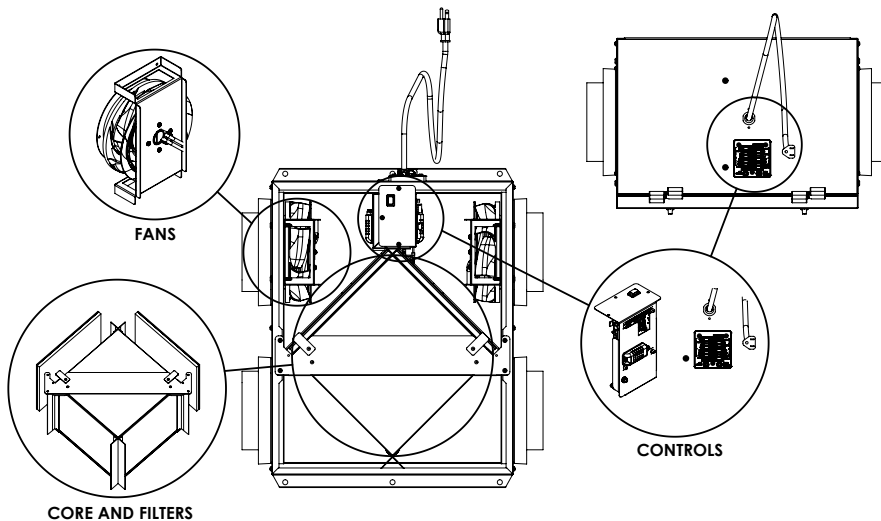

FIGURE 5.1.0 ERV COMPONENTS

5.2 CONTROL ACCESSORIES

If your EV Premium+ ERV is set to operate intermittently at a single speed, or employ Boost mode, you will have a control connected to the low voltage terminal block on the end of the unit. Full information for each control, including wiring diagrams can be found on www.renewaire.com.

5.2.1 Touchscreen Control+ (TC1+)

The Touchscreen Control+ (TC1+) can be used for advanced control for the EV Premium+ series as well as provide a solution that is compliant with 2025 California Energy Commission's (CEC) Title 24, Part 6 ERV Fault Indicator Display (FID) requirements. The interactive touchscreen will allow you to set airflow with a CFM setpoint (in increments of 5 CFM) or a percentage of max fan speed, activate BOOST mode, change ventilation mode, fault monitoring and indication, and display active airflow for each airstream and unit power. For more information on the TC1+, see the Touchscreen Control+ manual on RenewAire's website.

NOTE: The Touchscreen Control+ is required for setup, but does not need to stay connected for operation as dependent on desired features and code compliance.



FIGURE 5.2.0 TOUCHSCREEN CONTROL+ (TC1+)

5.2.2 Low Voltage Countdown Timer (LVCT)

The Low Voltage Countdown Timer (LVCT) is a point-of-use control with indicator lights that will operate your ERV with six selectable durations or always ON. If you select one of the selectable durations, a light will illuminate above to the corresponding selection. You can cancel the cycle at anytime by pressing the power/logo button. You can start another cycle by tapping the power/logo button or selecting a new duration. For more information on the LVCT, see the Low Voltage Countdown Timer manual on RenewAire's website.

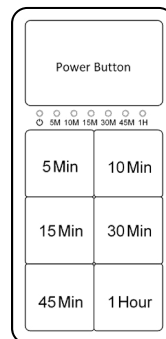

FIGURE 5.2.1 LOW VOLTAGE COUNTDOWN TIMER (LVCT)

5.2.3 Low Voltage Percentage Timer (LVPT)

The Low Voltage Percent Timer (LVPT) with indicator lights will operate your ERV an adjustable amount of time every hour. There are six selectable minutes per hour buttons or always ON. For the EV Premium+ units, the LVPT can be used for intermittent flow operation, or to trigger Boost mode. For more information on the LVPT, see the Low Voltage Percentage Timer manual on RenewAire's website.

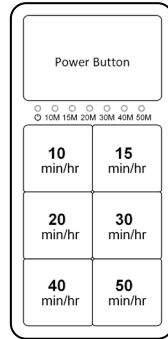

FIGURE 5.2.2 LOW VOLTAGE PERCENTAGE TIMER (LVPT)

5.2.4 Digital Time Clock (TC7D)

The Digital Time Clock (TC7D-W and TC7D-E) can be used to program scheduled operation for the ERV. The Time Clock supports schedules for individual days of the week, weekdays, weekends, and several other pre-program combinations of days. The time clock has an “ON,” “OFF” and “AUTO” mode. Auto mode allows the ERV to operate on the pre-programmed schedule, but On and Off modes can be used to override the schedule and force the ERV into operation or shutting off. For more information on the Time Clock, see the TC7D Series manual on RenewAire’s website.



FIGURE 5.2.3 TC7D CONTROL (WALL MOUNT)

5.2.5 CO2 Sensor, Occupancy Sensor and IAQ Sensor

EV Premium+ unit operation can also be controlled by a variety of sensors. The CO2 sensor can be set to operate the unit, or trigger Boost Mode, once the space exceeds the CO2 limit set by the sensor. Once the measured concentration has reduced below the threshold, the unit will return to normal operation, or turn off, depending on the installation. The IAQ sensor operates similarly to the CO2 sensor, except it will measure a variety of VOCs such as smoke, cooking odors, bio-effluence, outdoor pollutants, and from human activities.

The Occupancy sensor features a passive infrared sensor that will trigger the unit when the space is occupied and return to normal operation when the space is unoccupied.

For more information on these three sensors, refer to the individual control instruction manuals found on RenewAire’s website.



FIGURE 5.2.4 CO2, IAQ, AND MOTION OCCUPANCY SENSORS

IMPORTANT

This unit is only to be used after completion of building construction. It is not to be used during construction.

6.0 MAINTENANCE

The primary maintenance requirement is filter replacement. Filters are not to be cleaned, they must be replaced. The standard filter as shipped from the factory is a mesh-type, anti-microbial MERV 8. These standard filters are NOT to be sprayed with filter treatments or dust adhesives. The standard mesh-type OA MERV 8 filters may be replaced with pleated paper MERV 13 filters post-construction, if desired. Both filters should be replaced every three months, or more frequently, if needed, based on the cleanliness of the OA and RA air entering the unit.

The enthalpic core should be vacuumed annually. Remove the unit cover and then remove the filters for access to the core. Use a soft-bristled nozzle on a good vacuum and carefully vacuum the inlet faces of the core.

- Do not wash or allow the enthalpic cores to get wet.
- Do not expose the enthalpic cores to high heat or flames.
- Do not direct compressed air at the core media.
- Do not remove the enthalpic cores from the ERV unless necessary.
- Use caution when working around the enthalpic cores. Do not drop tools or other objects on the cores, do not bump or twist the cores.

Ducts should be inspected annually. Ensure all ducts and joints are free from damage, contaminants, or leaks in order for the system to behave properly.

6.1 MAINTENANCE AFTER 30 DAYS OPERATION

After 30 days of unit operation, check/tighten all mounting and support hardware. Inspect filters for cleanliness. There is often construction dust collected during initial operation. If filters appear dirty, replace them.

6.2 RECALIBRATION OF AIRFLOWS

Whenever the heating or ERV system in a residence is reconfigured, the unit may need to be recalibrated depending on the mode it is operating in. If it is running in constant volume mode, the unit will self-adjust to the new system effects. However, if it is running in constant speed mode (% of max speed), you will need to follow the procedure in Section 4.3. Common, but not limited to, changes that can trigger a recalibration include structural changes to the residence, adjustments to damper position or location, or switching filters from MERV 8 to MERV 13.

6.3 DOOR REMOVAL

The hinged door is held in place by two separable hinges on one edge and two security latches on the other edge. The separable hinges include a plastic clip to prevent accidental separation. To remove the door, first disconnect power to the unit. Unlatch and open the door and then strike the edge of the door, pushing the door toward the OA/EA side, in configuration A, of the unit.

6.4 SERVICE PARTS

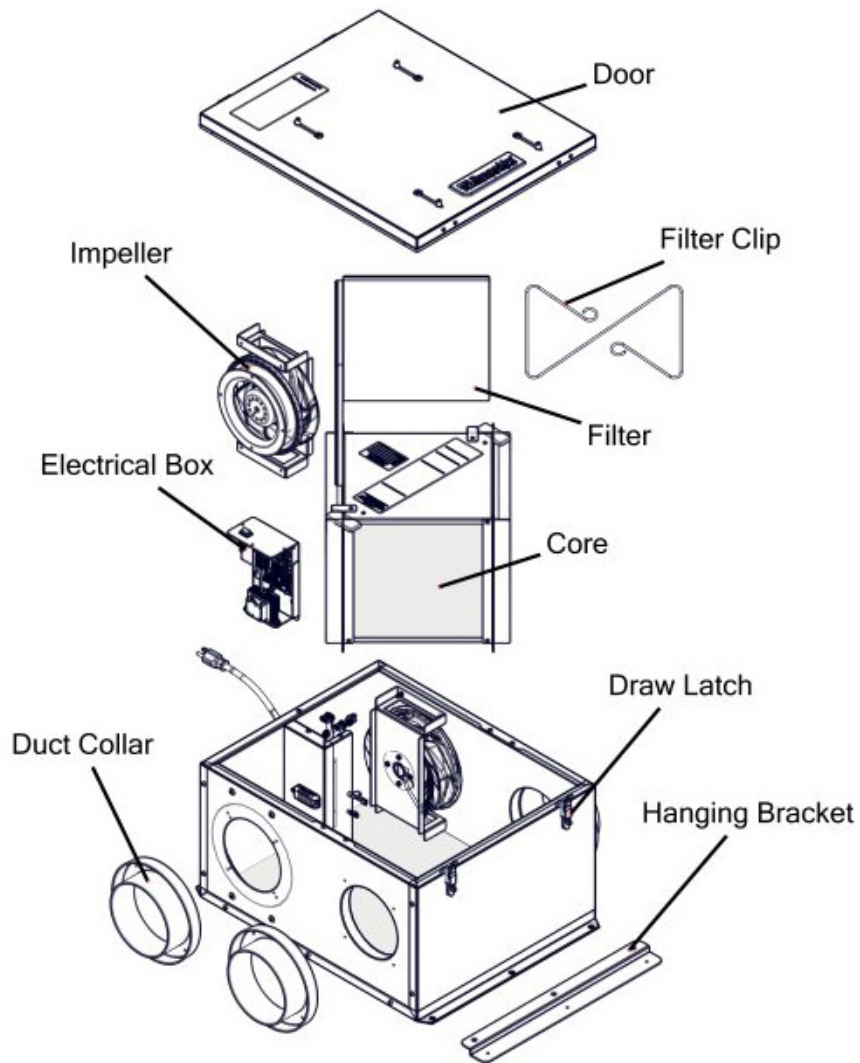

FIGURE 6.4.0 EV PREMIUM+ SERVICE PARTS

7.0 TROUBLESHOOTING

7.1 INDICATION OF PROBLEM

Indications of a problem with the ERV may be the perception that fresh air is not being delivered. The first step in resolving an apparent problem with an EV Premium+ ERV is to verify that there actually is a problem.

Regardless of the reason for thinking there is a problem with the EV Premium+, the first steps in troubleshooting are to check the air filters to make sure they are clean and properly positioned, and then do a hard restart of the unit. A hard restart involves unplugging the unit for several seconds and then plugging it back in. It takes a few moments for the control board to discharge. After reapplying power, check to see if resetting the circuit has solved the problem.

Because there are many different ways of ducting the SA into a dwelling, it is often difficult to say with certainty that the fresh air provided by the EV Premium+ is not reaching its intended destination or if the ERV is simply no longer providing enough fresh air. Determine where and how the fresh air is supposed to be delivered—if it is being carried in a dedicated duct directly to the air outlet, check for airflow at the outlet.

- Verify that dampers are still correctly positioned (open). If the ERV is being ducted into a main air handling system, shut the air handling system down so that airflow at the ducts can be detected.
- Check for airflow at the air openings nearest to the EV Premium+, not at the far end of the house. It may be necessary to hold a thin strip of tissue paper in front of a vent to realize whether or not there is airflow.
- Check for airflow in both low speed and high speed settings. It will be easier to detect airflow in the high speed setting.
- Check ducts and duct runs and problems with bends, sagging, etc.

7.2 ERV HAS AIRFLOW BUT IS MAKING NOISE

Feel the EV Premium+ while it is running to see if there is excessive vibration from the fans. Fan noise and vibration can be caused by an imbalance in the rotors or possibly by a bad bearing. Turn off power to the unit and rotate the fan impellers by hand. Make sure impellers rotate freely. Use wet swabs to clean any dust/dirt buildup off the impeller blades. If problem continues, a fan may have a bad bearing.

7.3 NO APPARENT AIRFLOW FROM THE ERV

If it seems that there is no apparent airflow, verify that it has power.

- If it does not have power, trace the power supply back to its source and isolate the problem or symptoms. Look for a switch turned off, a blown fuse or a tripped circuit breaker. If necessary, use a multimeter to trace the power supply and isolate the problem.
- If it has power and the fans will not run, disconnect all power to the unit and check the disconnect switch with an ohmmeter.
- If it has power, check to see if the fans are running by listening for fan noise and feeling the unit for vibration from the fans.
- If it has power and the fans are running, check the filters to make sure they are clean. Check the entire length of the ducts, all the way from the outdoor vent hoods to the indoor vent openings. Make sure a duct has not fallen off or that a flexible duct has not been pinched. In rare cases, there may be obstructions inside the duct. Look to see if a louver in an outdoor vent cap is stuck or blocked or if an indoor louver has been shut.
- If it has power but only one fan is running, disconnect all power to the unit and check the fan connectors to make sure they are still making contact.

7.4 INADEQUATE OR REDUCED AIRFLOW FROM THE ERV

If the unit has power and both fans are running, use a manometer to check the pressure differential across the core. See Section 4.3 Balancing Airflows in this manual. The results of a pressure differential test will provide correct information on how much air the unit is moving and also how the volume of air compares to when the unit was first installed. Check both low and high speed settings by changing the setpoints on the TC1+ or using a jumper on the terminal block from 24VAC to LOW or HIGH. Check ducts for bends, blockages, or leaks.

7.5 ERV FAILS TO RUN IN EITHER LOW SPEED OR HIGH SPEED MODE

The low-speed and high-speed modes operate independently of each other so there can be a failure in just one mode and it does not appear in the second mode. If one mode does not work, the problem can be isolated to either the controller or to an internal failure by bypassing the controller.

- Remove all wiring from the terminal block. Mark the wires so they can be reconnected in their proper locations.
- Install a jumper wire from the 24VAC terminal to the LOW speed terminal. Check for proper operation. Remove the jumper wire and install the jumper from 24VAC to the HIGH speed terminal. Remove the jumper wire and reinstall the control device wiring.

7.6 NO APPARENT REASON FOR LOW AIRFLOW

The final step in troubleshooting an ERV problem is to reset the airflow in both airstreams. Use a manometer and follow the instructions in Section 4.3 Balancing Airflows in this manual. Restore the pressure differential settings to their original airflow settings (CFM), as recorded in Section 4.4.

7.7 TOUCHSCREEN CONTROL+ FAULTS

Fault	Possible Cause	Action	Fault Clearing
Filter fault	Filter replacement is passed the recommended replacement period	Replace filters	1. Tap onscreen button 2. Press button on ERV terminal block with paperclip end or similarly sized object
Airflow low SA or Airflow low EA	Dirty or clogged filter	Replace filter	1. Tap onscreen button 2. Auto clear in 10s once acceptable conditions re-established
	Dirty or clogged enthalpic core	Remove and vacuum according to the ERV maintenance procedure above	
	Obstruction in the duct work or vent grill	Remove obstruction	
	Static pressure in duct run too high	Lower duct static pressure	
Motor RPM low SA or Motor RPM low EA	Wire connection interrupted or shorted	Inspect wire termination inside of the ERV from the start of the wire run on the motor all the way to the connection on the control board	1. Cycle unit power
	Software glitch	Unplug or electrically disconnect the ERV for 10s minimum and reconnect	
	Physical restriction or excessive debris	Remove/clean any obstruction	
Communication fault	Wire connection at termination loose, disconnected, or broken	Inspect wire termination at ERV and TC1+	1. Cycle unit power 2. Auto clear when communication re-established
	Software glitch	Unplug or electrically disconnect the ERV for 10s minimum and reconnect	
	Damaged wire behind walls or in open space from fasteners or objects	Inspect the wire run between the ERV and TC1+	

8.0 FACTORY ASSISTANCE

In the unlikely event that you need assistance from the factory for a specific issue, make sure that you have the information called for in the Unit Information page in the front of this manual. The person you speak with at the factory will need that information to properly identify the unit.

To contact RenewAire Customer Service:

Call 800-627-4499

Email: RenewAireSupport@RenewAire.com



About RenewAire

For over 40 years, **RenewAire** has been a pioneer in enhancing indoor air quality (IAQ) in commercial and residential buildings of every size. This is achieved while maximizing sustainability through our fifth-generation, static-plate, enthalpic-core **Energy Recovery Ventilators (ERVs)** that optimize energy efficiency, lower capital costs via load reduction and decrease operational expenses by minimizing equipment needs, resulting in significant energy savings. Our ERVs are competitively priced, simple to install, easy to use and maintain and have a quick payback. They also enjoy the industry's best warranty with the lowest claims due to long-term reliability derived from innovative design practices, expert workmanship and **Quick Response Manufacturing (QRM)**.

As the pioneer of static-plate core technology in North America, RenewAire is the largest ERV producer in the USA. We're **committed to sustainable manufacturing** and lessening our environmental footprint, and to that end our Waunakee, WI plant is 100% powered by wind turbines. The facility is also one of the few buildings worldwide to be LEED® Gold and Green Globes certified, as well as having achieved ENERGY STAR Building status. In 2010, RenewAire joined the Soler & Palau (S&P) Ventilation Group in order to provide direct access to the latest in energy-efficient air-moving technologies. For more information, visit: renewaire.com

201 Raemisch Road | Waunakee, WI | 53597 | 800.627.4499 | RenewAire.com